



NXP low-power bridges SC16IS7xx with available WinCE driver

Low-power bridge ICs with extended feature set

These compact protocol converters, designed for use with any I²C-bus or SPI bus master, enhance serial I/O connectivity. An extended feature set, made possible by a downloadable WinCE driver, increases design flexibility and delivers even faster time-to-market.

Key features

- ▶ Programmable baud rates: up to 921.6 K
- ▶ Data length: 5, 6, 7, 8
- ▶ Stop bits: 1, 1 ½, 2
- ▶ Parity type: Even, odd, none, mark, space
- ▶ Auto flow-control enable (hardware and software)
- ▶ Other programmable functions
 - Rx/Tx FIFO trigger levels
 - Hardware/software control trigger levels
 - XON/XOFF characters
- ▶ Set and clear RTS and DTR pins
- ▶ Read pin status (CD, RI, CTS, DSR)
- ▶ Extended feature set with downloadable WinCE driver

Applications

- ▶ Systems that need asynchronous serial ports
- ▶ TV tuners, PDAs, pocket and media PCs
- ▶ Mobile TVs, VoIP phones, smartphones
- ▶ Bluetooth interfaces, GPS navigation
- ▶ Wireless LAN radios, barcode scanners
- ▶ Portable media players, medical tablets
- ▶ Home gateways, IrDA remote controls

- ▶ Portable industrial control, power-metering equipment
- ▶ IP set-top boxes, Digital cameras
- ▶ Extra serial ports for software debug
- ▶ Car infotainment

The NXP SC16IS7xx series creates seamless, low-power, low-voltage connections for the most widely used interfaces (I²C-bus, GPIO, IrDA, SPI, UART), making it easy to add multiple devices to any application with I²C-bus or SPI bus interfaces. The result is reduced complexity, lower software overhead, and faster time-to-market.

Each bridge provides a slave I²C-bus/SIP interface to a high-performance UART with baud rates up to 5 Mbps with a 16x clock. The SC16IS740, SC16IS750, and SC16IS760 connect to a single UART, and the SC16IS752 and SC16IS762 connect to a dual UART.

The SC16IS75x and SC16IS76x provide eight configurable I/O pins. The SC16IS740 is the same as the SC16IS750, but without the configurable I/O.

Each UART has a FIFO depth of 64 bytes (transmitter and receiver). The bridges operate at a maximum clock frequency of 48 MHz (2.5 V) or 80 MHz (3.3 V) and throughout the industrial temperature range (-40 to +85 °C). When functioning as I²C-bus slaves, the bridges operate at up to 400 kbps with a choice of 16 hardware-selectable addresses.

The SC16IS75x supports SPI clock speeds of 4 Mbps, while the SC16IS76x supports SPI up to 15 Mbps and IrDA SIR up to 1.152 Mbps. In all other aspects, the SC16IS76x is the same as the SC16IS75x.

The internal register in each bridge is backward-compatible with the widely used 16C450 device, so software can be transferred to and from platforms. Designed for handheld, battery-operated applications, the SC16IS740 is housed in a small TSSOP16 package, and the SC16IS75x and SC16IS76x are available in small HVQFN24 and TSSOP24 packages.

Standard features include auto hardware and software flow control, automatic support for RS-485, and software reset, which enables UART resets at any time, independent of the hardware reset signal.

Extended feature set via downloadable WinCE driver.

A downloadable WinCE driver extends the feature set and shortens design time.

Written for Windows CE 5.0 and portable to other Windows CE versions, the driver was developed in conjunction with BSQUARE. It provides standard serial communication interface (COM) functions and lets application programs access the SC16IS7xx serial port and other functions, without involving the interface between the bridge and the rest of the system. The driver is easy to port to a host or embedded processor, including the XScale PXA270, so it's quick to set up and run.

SC16IS7xx family

Product	Description
SC16IS740	I ² C/SPI slave bridge to single UART with 64-byte FIFOs and 115.2-Kbps IrDA
SC16IS750	I ² C/SPI slave bridge to single UART with 64-byte FIFO, 115.2-Kbps IrDA, and 8 GPIO
SC16IS752	I ² C/SPI slave bridge to dual UART with 64-byte FIFO, 115.2-Kbps IrDA, and 8 GPIO
SC16IS760	I ² C/SPI slave bridge to single UART with 64-byte FIFO, 1.152-Mbps IrDA, and 8 GPIO
SC16IS762	I ² C/SPI slave bridge to dual UART with 64-byte FIFO, 1.152-Mbps IrDA, and 8 GPIO

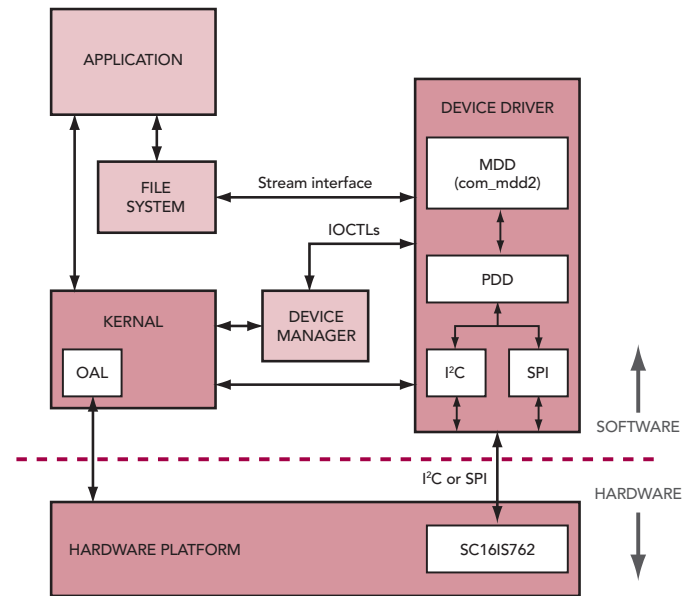

Block diagram of the downloadable WinCE SC16IS76xx device driver

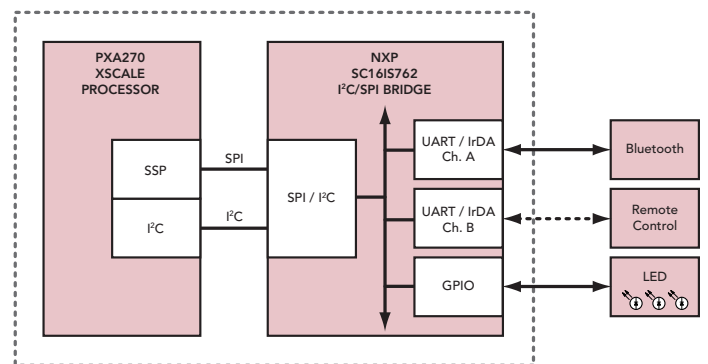

PXA270 processor block diagram for a typical system — I²C/SPI to UART/IrDA/GPIO

How to download

To download the driver, please send an email to interface.support@nxp.com

Extended feature set with downloadable WinCE driver

Configurable Tx/Rx interrupt trigger levels (any value between 1 and 64)
Configurable hardware/software flow control trigger levels (any value between 1 and 64)
Programmable I/O pins (input, output, interrupt on input change-of-state with optional latching)
I/O pins can switch to modem pins
UART software reset
Interrupt support (with counters) for modem status, line status, and CTS/RTS
XON support plus XOFF interrupt support (with counters)
Support for sleep mode
Enable / disable UART Rx/Tx

www.nxp.com



© 2007 NXP B.V.

All rights reserved. Reproduction in whole or in part is prohibited without the prior written consent of the copyright owner. The information presented in this document does not form part of any quotation or contract, is believed to be accurate and reliable and may be changed without notice. No liability will be accepted by the publisher for any consequence of its use. Publication thereof does not convey nor imply any license under patent or other industrial or intellectual property rights.

Date of release: August 2007

Document order number: 9397 750 15970

Printed in the USA