



LPC3220/30/40/50

16/32-bit ARM microcontrollers; hardware floating-point coprocessor, USB On-The-Go, and EMC memory interface

Rev. 01.02 — 7 January 2010

Product data sheet

1. General description

The LPC3220/30/40/50 embedded microcontrollers were designed for low power, high performance applications. NXP achieved their performance goals using a 90 nanometer process to implement an ARM926EJ-S CPU core with a vector floating point co-processor and a large set of standard peripherals including USB On-The-Go. The LPC3220/30/40/50 operates at CPU frequencies of up to 266 MHz.

The NXP implementation uses a ARM926EJ-S CPU core with a Harvard architecture, 5-stage pipeline, and an integral Memory Management Unit (MMU). The MMU provides the virtual memory capabilities needed to support the multi-programming demands of modern operating systems. The ARM926EJ-S also has a hardware based set of DSP instruction extensions, which includes single cycle MAC operations, and hardware based native Jazelle Java Byte-code execution. The NXP implementation has a 32 kB instruction cache and a 32 kB data cache.

For low power consumption, the LPC3220/30/40/50 takes advantage of NXP's advanced technology development to optimize intrinsic power and uses software controlled architectural enhancements to optimize application based power management.

The LPC3220/30/40/50 also includes 256 kB of on-chip static RAM, a NAND flash interface, an Ethernet MAC, an LCD controller that supports STN and TFT panels, and an external bus interface that supports SDR and DDR SDRAM as well as static devices. In addition, the LPC3220/30/40/50 includes a USB 2.0 full-speed interface, seven UARTs, two I²C-bus interfaces, two SPI/SSP ports, two I²S-bus interfaces, two single output PWMs, a motor control PWM, six general purpose timers with capture inputs and compare outputs, a Secure Digital (SD) interface, and a 10-bit Analog-to-Digital Converter (ADC) with a touch screen sense option.

2. Features

- ARM926EJS processor, running at CPU clock speeds up to 266 MHz.
- Vector Floating Point (VFP) coprocessor.
- 32 kB instruction cache and 32 kB data cache.
- Up to 256 kB of Internal SRAM (IRAM).
- Selectable boot-up from various external devices: NAND flash, SPI memory, USB, UART, or static memory.

- Multi-layer AHB system that provides a separate bus for each AHB master, including both an instruction and data bus for the CPU, two data busses for the DMA controller, and another bus for the USB controller, one for the LCD, and a final one for the Ethernet MAC. There are no arbitration delays in the system unless two masters attempt to access the same slave at the same time.
- External memory controller for DDR and SDR SDRAM as well as for static devices.
- Two NAND flash controllers: One for single-level NAND flash devices and the other for multi-level NAND flash devices.
- Master Interrupt Controller (MIC) and two Slave Interrupt Controllers (SIC), supporting 74 interrupt sources.
- Eight channel General Purpose DMA (GPDMA) controller on the AHB that can be used with the SD card port, the high-speed UARTs, I²S-bus interfaces, and SPI interfaces, as well as memory-to-memory transfers.
- Serial interfaces:
 - ◆ 10/100 Ethernet MAC with dedicated DMA Controller.
 - ◆ USB interface supporting either device, host (OHCI compliant), or On-The-Go (OTG) with an integral DMA controller and dedicated PLL to generate the required 48 MHz USB clock.
 - ◆ Four standard UARTs with fractional baud rate generation and 64 byte FIFOs. One of the standard UARTs supports IrDA.
 - ◆ Three additional high-speed UARTs intended for on-board communications that support baud rates up to 921 600 when using a 13 MHz main oscillator. All high-speed UARTs provide 64 byte FIFOs.
 - ◆ Two SPI controllers.
 - ◆ Two SSP controllers.
 - ◆ Two I²C-bus interfaces with standard open-drain pins. The I²C-bus interfaces support single master, slave, and multi-master I²C-bus configurations.
 - ◆ Two I²S-bus interfaces, each with separate input and output channels. Each channel can be operated independently on three pins, or both input and output channels can be used with only four pins and a shared clock.
- Additional peripherals:
 - ◆ LCD controller supporting both STN and TFT panels, with dedicated DMA controller. Programmable display resolution up to 1024 × 768.
 - ◆ Secure Digital (SD) memory card interface, which conforms to the *SD Memory Card Specification Version 1.01*.
 - ◆ General Purpose (GP) input, output, and I/O pins. Includes 12 GP input pins, 24 GP output pins, and 51 GP I/O pins.
 - ◆ 10-bit, 400 kHz Analog-to-Digital Converter (ADC) with input multiplexing from three pins. Optionally, the ADC can operate as a touch screen controller.
 - ◆ Real-Time Clock (RTC) with separate power pin and dedicated 32 kHz oscillator. NXP implemented the RTC in an independent on-chip power domain so it can remain active while the rest of the chip is not powered. The RTC also includes a 32-byte scratch pad memory.
 - ◆ 32-bit general purpose high-speed timer with a 16-bit pre-scaler. This timer includes one external capture input pin and a capture connection to the RTC clock. Interrupts may be generated using three match registers.

- ◆ Six enhanced timer/counters which are architecturally identical except for the peripheral base address. Two capture inputs and two match outputs are pinned out to four timers. Timer 1 brings out a third match output, timers 2 and 3 bring out all four match outputs, timer 4 has one match output, and timer 5 has no inputs or outputs.
- ◆ 32-bit millisecond timer driven from the RTC clock. This timer can generate interrupts using two match registers.
- ◆ WatchDog timer clocked by the peripheral clock.
- ◆ Two single-output PWM blocks.
- ◆ Motor control PWM.
- ◆ Keyboard scanner function allows automatic scanning of an up to 8×8 key matrix.
- ◆ Up to 18 external interrupts.
- Standard ARM test/debug interface for compatibility with existing tools.
- Emulation Trace Buffer (ETB) with 2048×24 bit RAM allows trace via JTAG.
- Stop mode saves power while allowing many peripheral functions to restart CPU activity.
- On-chip crystal oscillator.
- An on-chip PLL allows CPU operation up to the maximum CPU rate without the requirement for a high frequency crystal. Another PLL allows operation from the 32 kHz RTC clock rather than the external crystal.
- Boundary scan for simplified board testing.
- User-accessible unique serial ID number for each chip.
- 296 pin TFBGA package with a $15 \times 15 \times 0.7$ mm body.

3. Applications

- Consumer
- Medical
- Industrial
- Network control

4. Ordering information

Table 1. Ordering information

| Type number ^[1] | Package | | |
|---------------------------------|----------|--|-----------|
| | Name | Description | Version |
| LPC3220FET296 ^[2] | TFBGA296 | plastic thin fine-pitch ball grid array package; 296 balls | SOT1048-1 |
| LPC3230FET296 ^[2] | TFBGA296 | plastic thin fine-pitch ball grid array package; 296 balls | SOT1048-1 |
| LPC3240FET296 ^[2] | TFBGA296 | plastic thin fine-pitch ball grid array package; 296 balls | SOT1048-1 |
| LPC3250FET296 ^[2] | TFBGA296 | plastic thin fine-pitch ball grid array package; 296 balls | SOT1048-1 |
| LPC3220FET296/01 ^[3] | TFBGA296 | plastic thin fine-pitch ball grid array package; 296 balls | SOT1048-1 |
| LPC3230FET296/01 ^[3] | TFBGA296 | plastic thin fine-pitch ball grid array package; 296 balls | SOT1048-1 |
| LPC3240FET296/01 ^[3] | TFBGA296 | plastic thin fine-pitch ball grid array package; 296 balls | SOT1048-1 |
| LPC3250FET296/01 ^[3] | TFBGA296 | plastic thin fine-pitch ball grid array package; 296 balls | SOT1048-1 |

[1] F = -40 °C to +85 °C temperature range.

[2] Available in Revision “-” and “A”.

[3] Available starting with Revision “A”.

4.1 Ordering options

Table 2. Part options

| Type number | SRAM (kB) | 10/100 Ethernet | LCD controller | Temperature range (°C) | Package |
|------------------|-----------|-----------------|----------------|------------------------|----------|
| LPC3220FET296 | 128 | 0 | 0 | -40 to +85 | TFBGA296 |
| LPC3230FET296 | 256 | 0 | 1 | -40 to +85 | TFBGA296 |
| LPC3240FET296 | 256 | 1 | 0 | -40 to +85 | TFBGA296 |
| LPC3250FET296 | 256 | 1 | 1 | -40 to +85 | TFBGA296 |
| LPC3220FET296/01 | 128 | 0 | 0 | -40 to +85 | TFBGA296 |
| LPC3230FET296/01 | 256 | 0 | 1 | -40 to +85 | TFBGA296 |
| LPC3240FET296/01 | 256 | 1 | 0 | -40 to +85 | TFBGA296 |
| LPC3250FET296/01 | 256 | 1 | 1 | -40 to +85 | TFBGA296 |

5. Block diagram

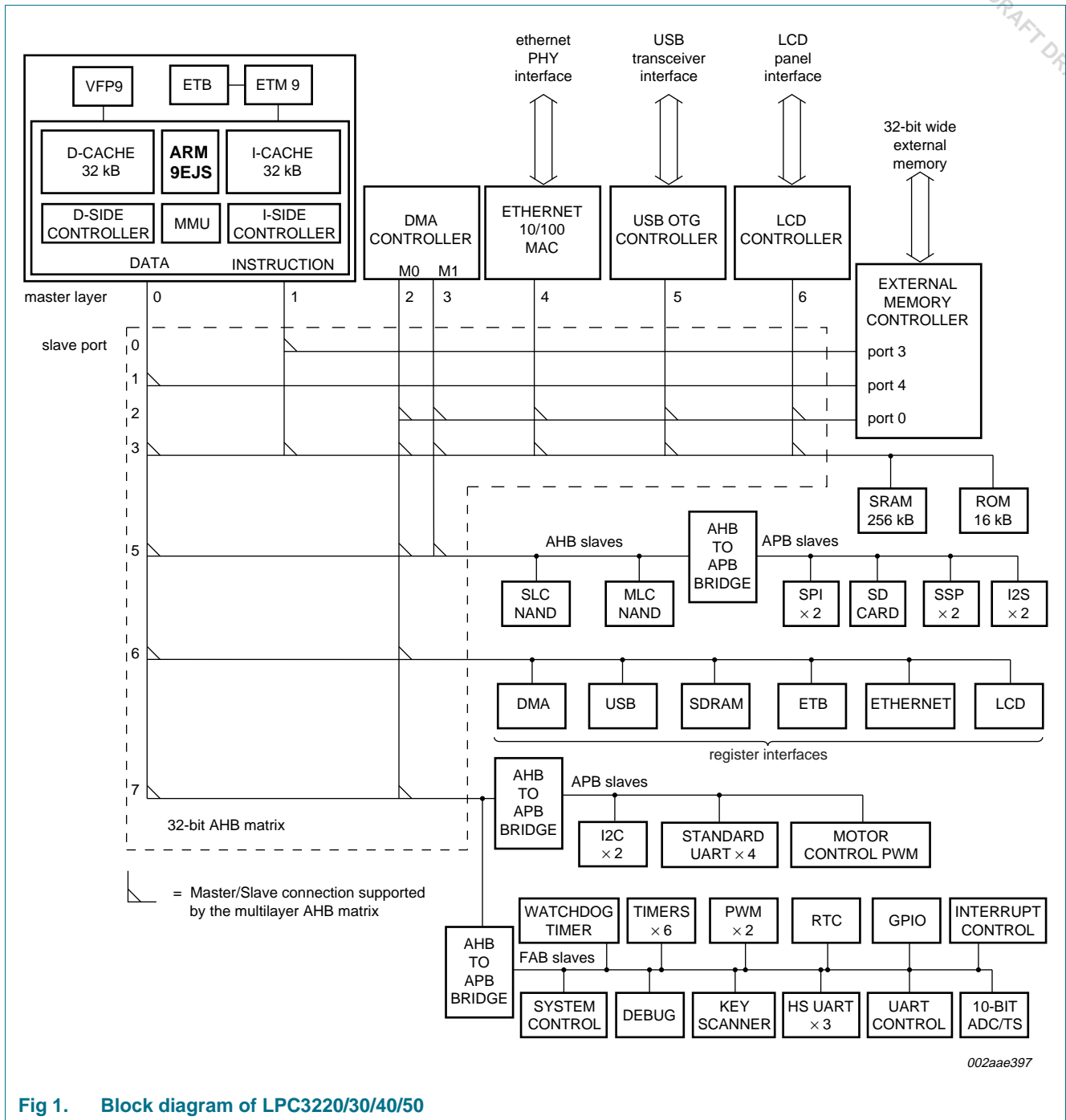

Fig 1. Block diagram of LPC3220/30/40/50

6. Pinning information

6.1 Pinning

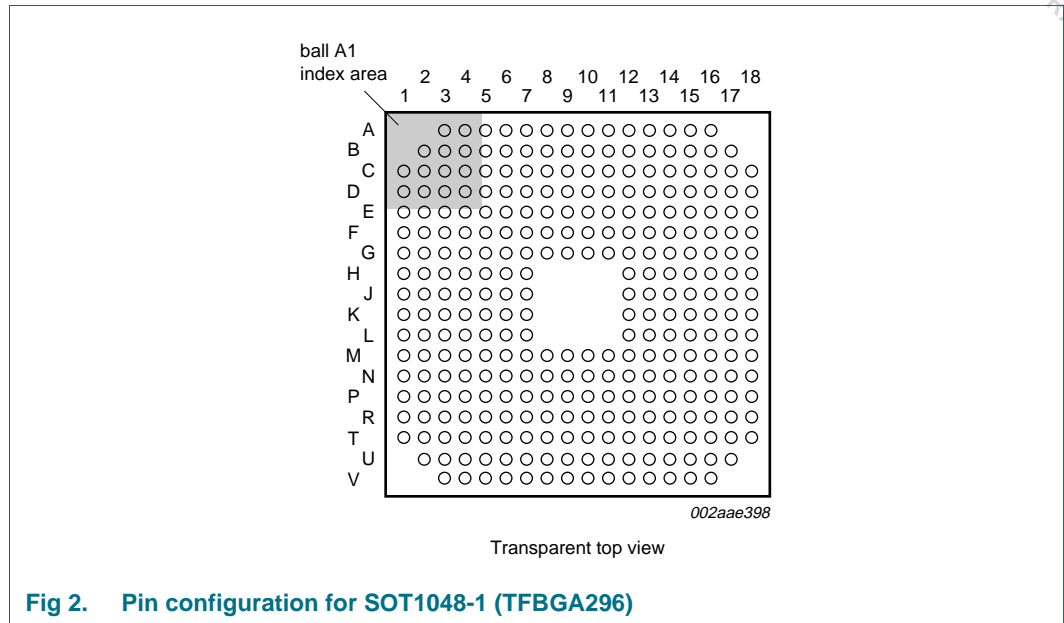

Table 3. Pin allocation table (TFBGA296)

| Pin | Symbol | Pin | Symbol | Pin | Symbol |
|--------------|--|-----|---------------------------------------|-----|---|
| Row A | | | | | |
| | | | | A3 | I2C2_SCL |
| A4 | I2S1TX_CLK/MAT3[0] | A5 | I2C1_SCL | A6 | MS_BS/MAT2[1] |
| A7 | MS_DIO1/MAT0[1] | A8 | MS_DIO0/MAT0[0] | A9 | SPI2_DATIO/MOSI1/LCDVD[20] ^[1] |
| A10 | SPI2_DATIN/MISO1/LCDVD[21] ^[1] /GPI_27 | A11 | GPIO_1 | A12 | GPIO_0 |
| A13 | GPO_21/U4_TX/LCDVD[3] ^[1] | A14 | GPO_15/MCOA1/LCDFP ^[1] | A15 | GPO_7/LCDVD[2] ^[1] |
| A16 | GPO_6/LCDVD[18] ^[1] | | | | |
| Row B | | | | | |
| | | B2 | GPO_20 | B3 | GPO_5 |
| B4 | I2S1TX_WS/CAP3[0] | B5 | P0[0]/I2S1RX_CLK | B6 | I2C1_SDA |
| B7 | MS_SCLK/MAT2[0] | B8 | MS_DIO2/MAT0[2] | B9 | SPI1_DATIO/MOSI0/MCI2 |
| B10 | SPI2_CLK/SCK1/LCDVD[23] ^[1] | B11 | GPIO_4/SSEL1/LCDVD[22] ^[1] | B12 | GPO_12/MCOA2/LCDLE ^[1] |
| B13 | GPO_13/MCOB1/LCDDCLK ^[1] | B14 | GPO_2/MAT1[0]/LCDVD[0] ^[1] | B15 | GPI_19/U4_RX |
| B16 | GPI_8/KEY_COL6/SPI2_BUSY/ENET_RX_DV ^[2] | B17 | n.c. | | |
| Row C | | | | | |
| C1 | FLASH_RD | C2 | GPO_19 | C3 | GPO_0/TST_CLK1 |
| C4 | USB_ATX_INT | C5 | USB_SE0_VM/U5_TX | C6 | TST_CLK2 |
| C7 | GPI_6/HSTIM_CAP/ENET_RXD2 ^[2] | C8 | MS_DIO3/MAT0[3] | C9 | SPI1_CLK/SCK0 |

Table 3. Pin allocation table (TFBGA296)

| Pin | Symbol | Pin | Symbol | Pin | Symbol |
|--------------|--|-----|---|-----|---|
| C10 | SPI1_DATIN/MISO0/GPI_25/ MCI1 | C11 | GPIO_3/KEY_ROW7/ ENET_MDIO ^[2] | C12 | GPO_9/LCDVD ^[9] ^[1] |
| C13 | GPO_8/LCDVD ^[8] ^[1] | C14 | GPI_2/CAP2 ^[0] / ENET_RXD3 ^[2] | C15 | GPI_1/ $\overline{\text{SERVICE}}$ |
| C16 | GPI_0/I2S1RX_SDA | C17 | KEY_ROW4/ENET_TXD0 ^[2] | C18 | KEY_ROW5/ENET_TXD1 ^[2] |
| Row D | | | | | |
| D1 | FLASH_RDY | D2 | FLASH_ALE | D3 | GPO_14 |
| D4 | GPO_1 | D5 | USB_DAT_VP/U5_RX | D6 | $\overline{\text{USB_OE_TP}}$ |
| D7 | P0 ^[1] /I2S1RX_WS | D8 | GPO_4 | D9 | GPIO_2/KEY_ROW6/ENET_MDC ^[2] |
| D10 | GPO_16/MCOB0/LCDENAB ^[1] / LCDM ^[1] | D11 | GPO_18/MCOA0/LCDLP ^[1] | D12 | GPO_3/LCDVD ^[1] ^[1] |
| D13 | GPI_7/CAP4 ^[0] / $\overline{\text{MCABORT}}$ | D14 | PWM_OUT1/LCDVD ^[16] ^[1] | D15 | PWM_OUT2/INTSTAT/LCDVD ^[19] ^[1] |
| D16 | KEY_ROW3/ENET_TX_EN ^[2] | D17 | KEY_COL2/ENET_RX_ER ^[2] | D18 | KEY_COL3/ENET_CRCS ^[2] |
| Row E | | | | | |
| E1 | FLASH_IO ^[3] | E2 | FLASH_IO ^[7] | E3 | $\overline{\text{FLASH_CE}}$ |
| E4 | I2C2_SDA | E5 | USB_I2C_SCL | E6 | USB_I2C_SDA |
| E7 | I2S1TX_SDA/MAT3 ^[1] | E8 | GPO_11 | E9 | GPIO_5/SSEL0/MCI0 |
| E10 | GPO_22/U7_HRTS/ LCDVD ^[14] ^[1] | E11 | GPO_10/MCOB2/LCDPWR ^[1] | E12 | GPI_9/KEY_COL7/ENET_COL ^[2] |
| E13 | GPI_4/SPI1_BUSY | E14 | KEY_ROW1/ENET_TXD2 ^[2] | E15 | KEY_ROW0/ENET_TX_ER ^[2] |
| E16 | KEY_COL1/ENET_RX_CLK ^[2] / ENET_REF_CLK ^[2] | E17 | U7_RX/CAP0 ^[0] / LCDVD ^[10] ^[1] /GPI_23 | E18 | U7_TX/MAT1 ^[1] /LCDVD ^[11] ^[1] |
| Row F | | | | | |
| F1 | FLASH_IO ^[2] | F2 | $\overline{\text{FLASH_WR}}$ | F3 | FLASH_CLE |
| F4 | GPI_3 | F5 | VSS_IOC | F6 | VSS_IOB |
| F7 | VDD_IOC | F8 | VDD_IOB | F9 | VDD_IOD |
| F10 | VSS_IOD | F11 | VSS_IOD | F12 | VSS_IOD |
| F13 | VDD_IOD | F14 | KEY_ROW2/ENET_TXD3 ^[2] | F15 | KEY_COL0/ENET_TX_CLK ^[2] |
| F16 | KEY_COL5/ENET_RXD1 ^[2] | F17 | U6_IRRX/GPI_21 | F18 | U5_RX/GPI_20 |
| Row G | | | | | |
| G1 | $\overline{\text{EMC_DYCS1}}$ | G2 | FLASH_IO ^[5] | G3 | FLASH_IO ^[6] |
| G4 | $\overline{\text{RESOUT}}$ | G5 | VSS_IOC | G6 | VDD_IOC |
| G7 | VDD_CORE | G8 | VSS_CORE | G9 | VDD_CORE |
| G10 | VSS_CORE | G11 | VDD_CORE | G12 | VSS_CORE |
| G13 | U7_HCTS/CAP0 ^[1] / LCDCLKIN ^[1] /GPI_22 | G14 | DBGEN | G15 | KEY_COL4/ENET_RXD0 ^[2] |
| G16 | U6_IRTX | G17 | SYSCLEN/LCDVD ^[15] ^[1] | G18 | JTAG_TMS |
| Row H | | | | | |
| H1 | $\overline{\text{EMC_OE}}$ | H2 | FLASH_IO ^[0] | H3 | FLASH_IO ^[1] |
| H4 | FLASH_IO ^[4] | H5 | VSS_IOC | H6 | VDD_IOC |
| H7 | VSS_CORE | | | H12 | VSS_IOD |
| H13 | VDD_IOA | H14 | JTAG_TCK | H15 | U5_TX |

Table 3. Pin allocation table (TFBGA296)

| Pin | Symbol | Pin | Symbol | Pin | Symbol |
|--------------|--|-----|---|-----|--|
| H16 | HIGHCORE/LCDVD[17] ^[1] | H17 | JTAG_NTRST | H18 | JTAG_RTCK |
| Row J | | | | | |
| J1 | EMC_A[20]/P1[20] | J2 | EMC_A[21]/P1[21] | J3 | EMC_A[22]/P1[22] |
| J4 | EMC_A[23]/P1[23] | J5 | VDD_IOC | J6 | VDD_EMCC |
| J7 | VDD_CORE | | | J12 | VDD_CORE |
| J13 | VDD_IOA | J14 | U3_RX/GPI_18 | J15 | JTAG_TDO |
| J16 | JTAG_TDI | J17 | U3_TX | J18 | U2_HCTS/U3_CTS/GPI_16 |
| Row K | | | | | |
| K1 | EMC_A[19]/P1[19] | K2 | EMC_A[18]/P1[18] | K3 | EMC_A[16]/P1[16] |
| K4 | EMC_A[17]/P1[17] | K5 | VSS_EMCC | K6 | VDD_EMCC |
| K7 | VDD_EMCC | | | K12 | VSS_CORE |
| K13 | VSS_IOA | K14 | VDD_RTC | K15 | U1_RX/CAP1[0]/GPI_15 |
| K16 | U1_TX | K17 | U2_TX/U3_DTR | K18 | U2_RX/U3_DSR/GPI_17 |
| Row L | | | | | |
| L1 | EMC_A[15]/P1[15] | L2 | EMC_CKE1 | L3 | EMC_A[0]/P1[0] |
| L4 | EMC_A[1]/P1[1] | L5 | VSS_EMCC | L6 | VDD_EMCC |
| L7 | VSS_CORE | | | L12 | VDD_COREFXD |
| L13 | VDD_RTCCORE | L14 | VSS_RTCCORE | L15 | P0[4]/I2S0RX_WS/LCDVD[6] ^[1] |
| L16 | P0[5]/I2S0TX_SDA/LCDVD[7] ^[1] | L17 | P0[6]/I2S0TX_CLK/LCDVD[12] ^[1] | L18 | P0[7]/I2S0TX_WS/LCDVD[13] ^[1] |
| Row M | | | | | |
| M1 | EMC_A[2]/P1[2] | M2 | EMC_A[3]/P1[3] | M3 | EMC_A[4]/P1[4] |
| M4 | EMC_A[8]/P1[8] | M5 | VSS_EMCC | M6 | VDD_EMCC |
| M7 | VDD_CORE | M8 | VDD_EMCC | M9 | VSS_CORE |
| M10 | VSS_CORE | M11 | VDD_CORE | M12 | VSS_CORE |
| M13 | VDD_COREFXD | M14 | RESET | M15 | ONSW |
| M16 | GPO_23/U2_HRTS/U3_RTS | M17 | P0[2]/I2S0RX_SDA/LCDVD[4] ^[1] | M18 | P0[3]/I2S0RX_CLK/LCDVD[5] ^[1] |
| Row N | | | | | |
| N1 | EMC_A[5]/P1[5] | N2 | EMC_A[6]/P1[6] | N3 | EMC_A[7]/P1[7] |
| N4 | EMC_A[12]/P1[12] | N5 | VSS_EMCC | N6 | VSS_EMCC |
| N7 | VDD_EMCC | N8 | VDD_EMCC | N9 | VDD_EMCC |
| N10 | VDD_EMCC | N11 | VDD_EMCC | N12 | VDD_AD |
| N13 | VDD_AD | N14 | VDD_FUSE | N15 | VDD_RTCOSC |
| N16 | GPI_5/U3_DCD | N17 | GPI_28/U3_RI | N18 | GPO_17 |
| Row P | | | | | |
| P1 | EMC_A[9]/P1[9] | P2 | EMC_A[10]/P1[10] | P3 | EMC_A[11]/P1[11] |
| P4 | EMC_DQM[1] | P5 | EMC_DQM[3] | P6 | VSS_EMCC |

Table 3. Pin allocation table (TFBGA296)

| Pin | Symbol | Pin | Symbol | Pin | Symbol |
|--------------|------------------|-----|--------------------|-----|--------------------|
| P7 | VSS_EMC | P8 | VSS_EMC | P9 | VSS_EMC |
| P10 | VSS_EMC | P11 | VSS_EMC | P12 | EMC_BLS[3] |
| P13 | VSS_AD | P14 | VSS_OSC | P15 | VDD_PLLUSB |
| P16 | RTCX_IN | P17 | RTCX_OUT | P18 | VSS_RTCOSC |
| Row R | | | | | |
| R1 | EMC_A[13]/P1[13] | R2 | EMC_A[14]/P1[14] | R3 | EMC_DQM[0] |
| R4 | EMC_WR | R5 | EMC_CAS | R6 | EMC_DYCS0 |
| R7 | EMC_D[1] | R8 | EMC_D[7] | R9 | EMC_D[17]/EMC_DQS1 |
| R10 | EMC_D[24]/P2[5] | R11 | EMC_CS1 | R12 | EMC_BLS[2] |
| R13 | TS_XP | R14 | PLL397_LOOP | R15 | SYSX_OUT |
| R16 | VSS_PLLUSB | R17 | VDD_PLLHCLK | R18 | VSS_PLLHCLK |
| Row T | | | | | |
| T1 | EMC_DQM[2] | T2 | EMC_RAS | T3 | EMC_CLK |
| T4 | EMC_CLKIN | T5 | EMC_D[2] | T6 | EMC_D[6] |
| T7 | EMC_D[11] | T8 | EMC_D[14] | T9 | EMC_D[20]/P2[1] |
| T10 | EMC_D[23]/P2[4] | T11 | EMC_D[27]/P2[8] | T12 | EMC_CS2 |
| T13 | EMC_BLS[1] | T14 | ADIN1/TS_XM | T15 | VSS_PLL397 |
| T16 | VDD_PLL397 | T17 | SYSX_IN | T18 | VDD_OSC |
| Row U | | | | | |
| | | U2 | n.c. | U3 | EMC_CKE0 |
| U4 | EMC_D[0] | U5 | EMC_D[3] | U6 | EMC_D[9] |
| U7 | EMC_D[12] | U8 | EMC_D[15] | U9 | EMC_D[19]/P2[0] |
| U10 | EMC_D[22]/P2[3] | U11 | EMC_D[26]/P2[7] | U12 | EMC_D[30]/P2[11] |
| U13 | EMC_CS0 | U14 | EMC_BLS[0] | U15 | ADIN0/TS_YM |
| U16 | TS_YP | U17 | n.c. | | |
| Row V | | | | | |
| | | | | V3 | EMC_D[4] |
| V4 | EMC_D[5] | V5 | EMC_D[8] | V6 | EMC_D[10] |
| V7 | EMC_D[13] | V8 | EMC_D[16]/EMC_DQS0 | V9 | EMC_D[18]/EMC_CLK |
| V10 | EMC_D[21]/P2[2] | V11 | EMC_D[25]/P2[6] | V12 | EMC_D[28]/P2[9] |
| V13 | EMC_D[29]/P2[10] | V14 | EMC_D[31]/P2[12] | V15 | EMC_CS3 |
| V16 | ADIN2/TS_AUX_IN | | | | |

[1] LCD on LPC3230 and LPC3250 only.

[2] Ethernet on LPC3240 and LPC3250 only.

6.2 Pin description

Table 4. Pin description

| Symbol | Pin | Power supply domain | Type | Description |
|------------------|-----|---------------------|-----------|---|
| ADIN0/TS_YM | U15 | VDD_AD | analog in | ADC input 0/touch screen Y minus |
| ADIN1/TS_XM | T14 | VDD_AD | analog in | ADC input 0/touch screen X minus |
| ADIN2/TS_AUX_IN | V16 | VDD_AD | analog in | ADC input 2/ touch screen AUX input |
| DBGEN | G14 | VDD_IOD | I: PD | Device test input (JTAG select = LOW; boundary scan = HIGH) |
| EMC_A[0]/P1[0] | L3 | VDD_EMC | I/O | EMC address bit 0 |
| | | | I/O | Port 1 GPIO bit 0 |
| EMC_A[1]/P1[1] | L4 | VDD_EMC | I/O | EMC address bit 1 |
| | | | I/O | Port 1 GPIO bit 1 |
| EMC_A[2]/P1[2] | M1 | VDD_EMC | I/O | EMC address bit 2 |
| | | | I/O | Port 1 GPIO bit 2 |
| EMC_A[3]/P1[3] | M2 | VDD_EMC | I/O | EMC address bit 3 |
| | | | I/O | Port 1 GPIO bit 3 |
| EMC_A[4]/P1[4] | M3 | VDD_EMC | I/O | EMC address bit 4 |
| | | | I/O | Port 1 GPIO bit 4 |
| EMC_A[5]/P1[5] | N1 | VDD_EMC | I/O | EMC address bit 5 |
| | | | I/O | Port 1 GPIO bit 5 |
| EMC_A[6]/P1[6] | N2 | VDD_EMC | I/O | EMC address bit 6 |
| | | | I/O | Port 1 GPIO bit 6 |
| EMC_A[7]/P1[7] | N3 | VDD_EMC | I/O | EMC address bit 7 |
| | | | I/O | Port 1 GPIO bit 7 |
| EMC_A[8]/P1[8] | M4 | VDD_EMC | I/O | EMC address bit 8 |
| | | | I/O | Port 1 GPIO bit 8 |
| EMC_A[9]/P1[9] | P1 | VDD_EMC | I/O | EMC address bit 9 |
| | | | I/O | Port 1 GPIO bit 9 |
| EMC_A[10]/P1[10] | P2 | VDD_EMC | I/O | EMC address bit 10 |
| | | | I/O | Port 1 GPIO bit 10 |
| EMC_A[11]/P1[11] | P3 | VDD_EMC | I/O | EMC address bit 11 |
| | | | I/O | Port 1 GPIO bit 11 |
| EMC_A[12]/P1[12] | N4 | VDD_EMC | I/O | EMC address bit 12 |
| | | | I/O | Port 1 GPIO bit 12 |
| EMC_A[13]/P1[13] | R1 | VDD_EMC | I/O | EMC address bit 13 |
| | | | I/O | Port 1 GPIO bit 13 |
| EMC_A[14]/P1[14] | R2 | VDD_EMC | I/O | EMC address bit 14 |
| | | | I/O | Port 1 GPIO bit 14 |
| EMC_A[15]/P1[15] | L1 | VDD_EMC | I/O | EMC address bit 15 |
| | | | I/O | Port 1 GPIO bit 15 |
| EMC_A[16]/P1[16] | K3 | VDD_EMC | I/O | EMC address bit 16 |
| | | | I/O | Port 1 GPIO bit 16 |

Table 4. Pin description ...continued

| Symbol | Pin | Power supply domain | Type | Description |
|------------------------------|-----|---------------------|---------|---|
| EMC_A[17]/P1[17] | K4 | VDD_EMC | I/O | EMC address bit 17 |
| | | | I/O | Port 1 GPIO bit 17 |
| EMC_A[18]/P1[18] | K2 | VDD_EMC | I/O | EMC address bit 18 |
| | | | I/O | Port 1 GPIO bit 18 |
| EMC_A[19]/P1[19] | K1 | VDD_EMC | I/O | EMC address bit 19 |
| | | | I/O | Port 1 GPIO bit 19 |
| EMC_A[20]/P1[20] | J1 | VDD_EMC | I/O | EMC address bit 20 |
| | | | I/O | Port 1 GPIO bit 20 |
| EMC_A[21]/P1[21] | J2 | VDD_EMC | I/O | EMC address bit 21 |
| | | | I/O | Port 1 GPIO bit 21 |
| EMC_A[22]/P1[22] | J3 | VDD_EMC | I/O | EMC address bit 22 |
| | | | I/O | Port 1 GPIO bit 22 |
| EMC_A[23]/P1[23] | J4 | VDD_EMC | I/O | EMC address bit 23 |
| | | | I/O | Port 1 GPIO bit 23 |
| EMC_BLS[0] | U14 | VDD_EMC | O | Static memory byte lane 0 select |
| EMC_BLS[1] | T13 | VDD_EMC | O | Static memory byte lane 1 select |
| EMC_BLS[2] | R12 | VDD_EMC | O | Static memory byte lane 2 select |
| EMC_BLS[3] | P12 | VDD_EMC | O | Static memory byte lane 3 select |
| $\overline{\text{EMC_CAS}}$ | R5 | VDD_EMC | O | SDRAM column address strobe out, active LOW |
| EMC_CKE0 | U3 | VDD_EMC | O | Clock enable out for SDRAM bank 0 |
| EMC_CKE1 | L2 | VDD_EMC | O | Clock enable out for SDRAM bank 1 |
| EMC_CLK | T3 | VDD_EMC | O | SDRAM clock out |
| EMC_CLKIN | T4 | VDD_EMC | I | SDRAM clock feedback |
| $\overline{\text{EMC_CS0}}$ | U13 | VDD_EMC | O | EMC static memory chip select 0 |
| $\overline{\text{EMC_CS1}}$ | R11 | VDD_EMC | O | EMC static memory chip select 1 |
| $\overline{\text{EMC_CS2}}$ | T12 | VDD_EMC | O | EMC static memory chip select 2 |
| $\overline{\text{EMC_CS3}}$ | V15 | VDD_EMC | O | EMC static memory chip select 3 |
| EMC_D[0] | U4 | VDD_EMC | I/O: BK | EMC data bit 0 |
| EMC_D[1] | R7 | VDD_EMC | I/O: BK | EMC data bit 1 |
| EMC_D[2] | T5 | VDD_EMC | I/O: BK | EMC data bit 2 |
| EMC_D[3] | U5 | VDD_EMC | I/O: BK | EMC data bit 3 |
| EMC_D[4] | V3 | VDD_EMC | I/O: BK | EMC data bit 4 |
| EMC_D[5] | V4 | VDD_EMC | I/O: BK | EMC data bit 5 |
| EMC_D[6] | T6 | VDD_EMC | I/O: BK | EMC data bit 6 |
| EMC_D[7] | R8 | VDD_EMC | I/O: BK | EMC data bit 7 |
| EMC_D[8] | V5 | VDD_EMC | I/O: BK | EMC data bit 8 |
| EMC_D[9] | U6 | VDD_EMC | I/O: BK | EMC data bit 9 |
| EMC_D[10] | V6 | VDD_EMC | I/O: BK | EMC data bit 10 |
| EMC_D[11] | T7 | VDD_EMC | I/O: BK | EMC data bit 11 |
| EMC_D[12] | U7 | VDD_EMC | I/O: BK | EMC data bit 12 |

Table 4. Pin description ...continued

| Symbol | Pin | Power supply domain | Type | Description |
|------------------------|-----|---------------------|---------|--------------------------------|
| EMC_D[13] | V7 | VDD_EMC | I/O: BK | EMC data bit 13 |
| EMC_D[14] | T8 | VDD_EMC | I/O: BK | EMC data bit 14 |
| EMC_D[15] | U8 | VDD_EMC | I/O: BK | EMC data bit 15 |
| EMC_D[16]/ EMC_DQS0 | V8 | VDD_EMC | I/O: BK | EMC data bit 16 |
| | | | I/O: BK | DDR data strobe 0 |
| EMC_D[17]/ EMC_DQS1 | R9 | VDD_EMC | I/O: BK | EMC data bit 17 |
| | | | I/O: BK | DDR data strobe 1 |
| EMC_D[18]/ EMC_CLK | V9 | VDD_EMC | I/O: P | EMC data bit 18 |
| | | | I/O: P | DDR inverted clock output |
| EMC_D[19]/P2[0] | U9 | VDD_EMC | I/O: P | EMC data bit 19 |
| | | | I/O: P | Port 2 GPIO bit 0 |
| EMC_D[20]/P2[1] | T9 | VDD_EMC | I/O: P | EMC data bit 20 |
| | | | I/O: P | Port 2 GPIO bit 1 |
| EMC_D[21]/P2[2] | V10 | VDD_EMC | I/O: P | EMC data bit 21 |
| | | | I/O: P | Port 2 GPIO bit 2 |
| EMC_D[22]/P2[3] | U10 | VDD_EMC | I/O: P | EMC data bit 22 |
| | | | I/O: P | Port 2 GPIO bit 3 |
| EMC_D[23]/P2[4] | T10 | VDD_EMC | I/O: P | EMC data bit 23 |
| | | | I/O: P | Port 2 GPIO bit 4 |
| EMC_D[24]/P2[5] | R10 | VDD_EMC | I/O: P | EMC data bit 24 |
| | | | I/O: P | Port 2 GPIO bit 5 |
| EMC_D[25]/P2[6] | V11 | VDD_EMC | I/O: P | EMC data bit 25 |
| | | | I/O: P | Port 2 GPIO bit 6 |
| EMC_D[26]/P2[7] | U11 | VDD_EMC | I/O: P | EMC data bit 26 |
| | | | I/O: P | Port 2 GPIO bit 7 |
| EMC_D[27]/P2[8] | T11 | VDD_EMC | I/O: P | EMC data bit 27 |
| | | | I/O: P | Port 2 GPIO bit 8 |
| EMC_D[28]/P2[9] | V12 | VDD_EMC | I/O: P | EMC data bit 28 |
| | | | I/O: P | Port 2 GPIO bit 9 |
| EMC_D[29]/P2[10] | V13 | VDD_EMC | I/O: P | EMC data bit 29 |
| | | | I/O: P | Port 2 GPIO bit 10 |
| EMC_D[30]/P2[11] | U12 | VDD_EMC | I/O: P | EMC data bit 30 |
| | | | I/O: P | Port 2 GPIO bit 11 |
| EMC_D[31]/P2[12] | V14 | VDD_EMC | I/O: P | EMC data bit 31 |
| | | | I/O: P | Port 2 GPIO bit 12 |
| EMC_DQM[0] | R3 | VDD_EMC | O | SDRAM data mask 0 out |
| EMC_DQM[1] | P4 | VDD_EMC | O | SDRAM data mask 1 out |
| EMC_DQM[2] | T1 | VDD_EMC | O | SDRAM data mask 2 out |
| EMC_DQM[3] | P5 | VDD_EMC | O | SDRAM data mask 3 out |
| EMC_DYCS0 | R6 | VDD_EMC | O | SDRAM active LOW chip select 0 |

Table 4. Pin description ...continued

| Symbol | Pin | Power supply domain | Type | Description |
|------------------------------------|-----|---------------------|---------|--|
| $\overline{\text{EMC_DYCS1}}$ | G1 | VDD_EMC | O | SDRAM active LOW chip select 1 |
| $\overline{\text{EMC_OE}}$ | H1 | VDD_EMC | O | EMC static memory output enable |
| $\overline{\text{EMC_RAS}}$ | T2 | VDD_EMC | O | SDRAM row address strobe, active LOW |
| $\overline{\text{EMC_WR}}$ | R4 | VDD_EMC | O | EMC write strobe, active LOW |
| FLASH_ALE | D2 | VDD_IOC | O | Flash address latch enable |
| $\overline{\text{FLASH_CE}}$ | E3 | VDD_IOC | O | Flash chip enable |
| FLASH_CLE | F3 | VDD_IOC | O | Flash command latch enable |
| FLASH_IO[0] | H2 | VDD_IOC | I/O: BK | Flash data bus, bit 0 |
| FLASH_IO[1] | H3 | VDD_IOC | I/O: BK | Flash data bus, bit 1 |
| FLASH_IO[2] | F1 | VDD_IOC | I/O: BK | Flash data bus, bit 2 |
| FLASH_IO[3] | E1 | VDD_IOC | I/O: BK | Flash data bus, bit 3 |
| FLASH_IO[4] | H4 | VDD_IOC | I/O: BK | Flash data bus, bit 4 |
| FLASH_IO[5] | G2 | VDD_IOC | I/O: BK | Flash data bus, bit 5 |
| FLASH_IO[6] | G3 | VDD_IOC | I/O: BK | Flash data bus, bit 6 |
| FLASH_IO[7] | E2 | VDD_IOC | I/O: BK | Flash data bus, bit 7 |
| $\overline{\text{FLASH_RD}}$ | C1 | VDD_IOC | O | Flash read enable |
| FLASH_RDY | D1 | VDD_IOC | I | Flash ready (from flash device) |
| $\overline{\text{FLASH_WR}}$ | F2 | VDD_IOC | O | Flash write enable |
| GPI_0/I2S1RX_SDA | C16 | VDD_IOD | I | General purpose input 0 |
| | | | I | I ² S1 Receive data |
| GPI_1/ $\overline{\text{SERVICE}}$ | C15 | VDD_IOD | I | General purpose input 1 |
| | | | I | Boot select input |
| GPI_2/CAP2[0]/ ENET_RXD3 | C14 | VDD_IOD | I | General purpose input 2 |
| | | | I | Timer 2 capture input 0 |
| | | | I | Ethernet receive data 3 (LPC3240 and LPC3250 only) |
| GPI_3 | F4 | VDD_IOC | I | General purpose input 3 |
| GPI_4/SPI1_BUSY | E13 | VDD_IOD | I | General purpose input 4 |
| | | | I | SPI1 busy input |
| GPI_5/U3_DCD | N16 | VDD_IOA | I | General purpose input 5 |
| | | | I | UART 3 data carrier detect input |
| GPI_6/ HSTIM_CAP/ ENET_RXD2 | C7 | VDD_IOB | I | General purpose input 6 |
| | | | I | High-speed timer capture input |
| | | | I | Ethernet receive data 2 (LPC3240 and LPC3250 only) |
| GPI_7/CAP4[0]/ MCABORT | D13 | VDD_IOD | I | General purpose input 7 |
| | | | I | Timer 4 capture input 0 |
| | | | I | Motor control PWM LOW-active fast abort input |

Table 4. Pin description ...continued

| Symbol | Pin | Power supply domain | Type | Description |
|---|-----|---------------------|------|--|
| GPI_8/KEY_COL6/ SPI2_BUSY/ ENET_RX_DV | B16 | VDD_IOD | I | General purpose input 8 |
| | | | I | Keyscan column 6 input |
| | | | I | SPI2 busy input |
| | | | I | Ethernet receive data valid input (LPC3240 and LPC3250 only) |
| GPI_9/KEY_COL7/ ENET_COL | E12 | VDD_IOD | I | General purpose input 9 |
| | | | I | Keyscan column 7 input |
| | | | I | Ethernet collision input (LPC3240 and LPC3250 only) |
| GPI_19/U4_RX | B15 | VDD_IOD | I | General purpose input 19 |
| | | | I | UART 4 receive |
| GPI_28/U3_RI | N17 | VDD_IOA | I | General purpose input 28 |
| | | | I | UART 3 ring indicator input |
| GPIO_0 | A12 | VDD_IOD | I/O | General purpose input/output 0 |
| GPIO_1 | A11 | VDD_IOD | I/O | General purpose input/output 1 |
| GPIO_2/ KEY_ROW6/ ENET_MDC | D9 | VDD_IOD | I/O | General purpose input/output 2 |
| | | | O | Keyscan row 6 output |
| | | | O | Ethernet PHY interface clock (LPC3240 and LPC3250 only) |
| GPIO_3/ KEY_ROW7/ ENET_MDIO | C11 | VDD_IOD | I/O | General purpose input/output 3 |
| | | | I/O | Keyscan row 7 output |
| | | | I/O | Ethernet PHY interface data (LPC3240 and LPC3250 only) |
| GPIO_4/ SSEL1/ LCDVD[22] | B11 | VDD_IOD | I/O | General purpose input/output 4 |
| | | | I/O | SSP1 Slave Select |
| | | | I/O | LCD data bit 22 (LPC3230 and LPC3250 only) |
| GPIO_5/ SSEL0/ MCI0 | E9 | VDD_IOD | I/O | General purpose input/output 5 |
| | | | I/O | SSP0 Slave Select |
| | | | I/O | Motor control channel 0 input |
| GPO_0/ TST_CLK1 | C3 | VDD_IOC | O | General purpose output 0 |
| | | | O | Test clock 1 out |
| GPO_1 | D4 | VDD_IOC | O | General purpose output 1 |
| | | | O | Timer 1 match output 0 |
| | | | | O |
| GPO_2/ MAT1[0]/ LCDVD[0] | B14 | VDD_IOD | O | General purpose output 2 |
| | | | O | LCD data bit 1 (LPC3230 and LPC3250 only) |
| GPO_3/ LCDVD[1] | D12 | VDD_IOD | O | General purpose output 3 |
| | | | O | LCD data bit 1 (LPC3230 and LPC3250 only) |
| GPO_4 | D8 | VDD_IOB | O | General purpose output 4 |
| GPO_5 | B3 | VDD_IOC | O | General purpose output 5 |
| GPO_6/ LCDVD[18] | A16 | VDD_IOD | O | General purpose output 6 |
| | | | O | LCD data bit 18 (LPC3230 and LPC3250 only) |

Table 4. Pin description ...continued

| Symbol | Pin | Power supply domain | Type | Description |
|-----------------------------------|-----|---------------------|------|--|
| GPO_7/ LCDVD[2] | A15 | VDD_IOD | O | General purpose output 7 |
| | | | O | LCD data bit 2 (LPC3230 and LPC3250 only) |
| GPO_8/ LCDVD[8] | C13 | VDD_IOD | O | General purpose output 8 |
| | | | O | LCD data bit 8 (LPC3230 and LPC3250 only) |
| GPO_9/ LCDVD[9] | C12 | VDD_IOD | O | General purpose output 9 |
| | | | O | LCD data bit 9 (LPC3230 and LPC3250 only) |
| GPO_10/ MCOB2/ LCDPWR | E11 | VDD_IOD | O | General purpose output 10 |
| | | | O | Motor control PWM channel 2, output B |
| | | | O | LCD panel power enable (LPC3230 and LPC3250 only) |
| GPO_11 | E8 | VDD_IOB | O | General purpose output 11 |
| GPO_12/ MCOA2/ LCDLE | B12 | VDD_IOD | O | General purpose output 12 |
| | | | O | Motor control PWM channel 2, output A |
| | | | O | LCD line end signal (LPC3230 and LPC3250 only) |
| GPO_13/ MCOB1/ LCDDCLK | B13 | VDD_IOD | O | General purpose output 13 |
| | | | O | Motor control PWM channel 1, output B |
| | | | O | LCD clock output (LPC3230 and LPC3250 only) |
| GPO_14 | D3 | VDD_IOC | O | General purpose output 14 |
| GPO_15/ MCOA1/ LCDFP | A14 | VDD_IOD | O | General purpose output 15 |
| | | | O | Motor control PWM channel 1, output A |
| | | | O | LCD frame/sync pulse (LPC3230 and LPC3250 only) |
| GPO_16/ MCOB0/ LCDENAB/LCDM | D10 | VDD_IOD | O | General purpose output 16 |
| | | | O | Motor control PWM channel 0, output B |
| | | | O | LCD STN AC bias/TFT data enable (LPC3230 and LPC3250 only) |
| GPO_17 | N18 | VDD_IOA | O | General purpose output 17 |
| GPO_18/ MCOA0/ LCDLP | D11 | VDD_IOD | O | General purpose output 18 |
| | | | O | Motor control PWM channel 0, output A |
| | | | O | LCD line sync/horizontal sync (LPC3230 and LPC3250 only) |
| GPO_19 | C2 | VDD_IOC | O | General purpose output 19 |
| GPO_20 | B2 | VDD_IOC | O | General purpose output 20 |
| GPO_21/ U4_TX/ LCDVD[3] | A13 | VDD_IOD | O | General purpose output 21 |
| | | | O | UART 4 transmit |
| | | | O | LCD data bit 3 (LPC3230 and LPC3250 only) |
| GPO_22/ U7_HRTS/ LCDVD[14] | E10 | VDD_IOD | O | General purpose output 22 |
| | | | O | HS UART 7 RTS out |
| | | | O | LCD data bit 14 (LPC3230 and LPC3250 only) |

Table 4. Pin description ...continued

| Symbol | Pin | Power supply domain | Type | Description |
|---|-----|---------------------|-------|--|
| GPO_23/ U2_HRTS/ U3_RTS | M16 | VDD_IOA | O | General purpose output 23 |
| | | | O | HS UART 2 RTS out |
| | | | O | UART 3 RTS out |
| HIGHCORE/ LCDVD[17] | H16 | VDD_IOD | O | Core voltage control out |
| | | | O | LCD data bit 17 (LPC3230 and LPC3250 only) |
| I2C1_SCL | A5 | VDD_IOB | I/O T | I ² C1 serial clock input/output |
| I2C1_SDA | B6 | VDD_IOB | I/O T | I ² C1 serial data input/output |
| I2C2_SCL | A3 | VDD_IOC | I/O T | I ² C2 serial clock input/output |
| I2C2_SDA | E4 | VDD_IOC | I/O T | I ² C2 serial data input/output |
| I2S1TX_CLK/ MAT3[0] | A4 | VDD_IOB | I/O | I ² S1 transmit clock |
| | | | O | Timer 3 match output 0 |
| I2S1TX_SDA/ MAT3[1] | E7 | VDD_IOB | I/O | I ² S1 transmit data |
| | | | O | Timer 3 match output 1 |
| I2S1TX_WS/ CAP3[0] | B4 | VDD_IOB | I/O | I ² S1 transmit word select |
| | | | I/O | Timer 3 capture input 0 |
| JTAG_NTRST | H17 | VDD_IOD | I: PU | JTAG1 reset input |
| JTAG_RTCK | H18 | VDD_IOD | O | JTAG1 return clock out |
| JTAG_TCK | H14 | VDD_IOD | I | JTAG1 clock input |
| JTAG_TDI | J16 | VDD_IOD | I: PU | JTAG1 data input |
| JTAG_TDO | J15 | VDD_IOD | O | JTAG1 data out |
| JTAG_TMS | G18 | VDD_IOD | I: PU | TAG1 test mode select input |
| | | | | |
| KEY_COL0/ ENET_TX_CLK | F15 | VDD_IOD | I | Keyscan column 0 input |
| | | | I | Ethernet transmit clock (LPC3240 and LPC3250 only) |
| KEY_COL1/ ENET_RX_CLK/ ENET_REF_CLK | E16 | VDD_IOD | I | Keyscan column 1 input |
| | | | I | Ethernet receive clock (MII mode, LPC3240 and LPC3250 only) |
| | | | I | Ethernet reference clock (RMII mode, LPC3240 and LPC3250 only) |
| KEY_COL2/ ENET_RX_ER | D17 | VDD_IOD | I | Keyscan column 2 input |
| | | | I | Ethernet receive error input (LPC3240 and LPC3250 only) |
| KEY_COL3/ ENET_CRS | D18 | VDD_IOD | I | Keyscan column 3 input |
| | | | I | Ethernet carrier sense input (LPC3240 and LPC3250 only) |
| KEY_COL4/ ENET_RXD0 | G15 | VDD_IOD | I | Keyscan column 4 input |
| | | | I | Ethernet receive data 0 (LPC3240 and LPC3250 only) |
| KEY_COL5/ ENET_RXD1 | F16 | VDD_IOD | I | Keyscan column 5 input |
| | | | I | Ethernet receive data 1 (LPC3240 and LPC3250 only) |

Table 4. Pin description ...continued

| Symbol | Pin | Power supply domain | Type | Description |
|-----------------------------------|--------------------|---------------------|--------|---|
| KEY_ROW0/ ENET_TX_ER | E15 | VDD_IOD | I/O T | Keyscan row 0 out |
| | | | I/O T | Ethernet transmit error (LPC3240 and LPC3250 only) |
| KEY_ROW1/ ENET_TXD2 | E14 | VDD_IOD | I/O T | Keyscan row 1 out |
| | | | I/O T | Ethernet transmit data 2 (LPC3240 and LPC3250 only) |
| KEY_ROW2/ ENET_TXD3 | F14 | VDD_IOD | I/O T | Keyscan row 2 out |
| | | | I/O T | Ethernet transmit data 3 (LPC3240 and LPC3250 only) |
| KEY_ROW3/ ENET_TX_EN | D16 | VDD_IOD | I/O T | Keyscan row 3 out |
| | | | I/O T | Ethernet transmit enable (LPC3240 and LPC3250 only) |
| KEY_ROW4/ ENET_TXD0 | C17 | VDD_IOD | I/O T | Keyscan row 4 out |
| | | | I/O T | Ethernet transmit data 0 (LPC3240 and LPC3250 only) |
| KEY_ROW5/ ENET_TXD1 | C18 | VDD_IOD | I/O T | Keyscan row 5 out |
| | | | I/O T | Ethernet transmit data 1 (LPC3240 and LPC3250 only) |
| MS_BS/MAT2[1] | A6 | VDD_IOD | I/O: P | MS/SD card command out |
| | | | O | Timer 2 match output 1 |
| MS_DIO0/MAT0[0] | A8 | VDD_IOD | I/O: P | MS/SD card data 0 |
| | | | O | Timer 0 match output 0 |
| MS_DIO1/ MAT0[1] | A7 | VDD_IOD | I/O: P | MS/SD card data 1 |
| | | | O | Timer 0 match output 1 |
| MS_DIO2/ MAT0[2] | B8 | VDD_IOD | I/O: P | MS/SD card data 2 |
| | | | O | Timer 0 match output 2 |
| MS_DIO3/ MAT0[3] | C8 | VDD_IOD | I/O: P | MS/SD card data 3 |
| | | | O | Timer 0 match output 3 |
| MS_SCLK/ MAT2[0] | B7 | VDD_IOD | I/O | MS/SD card clock output |
| | | | O | Timer 2 match output 0 |
| n.c. | B17, U17, U2 | - | - | not connected |
| ONSW | M15 | VDD_RTC | O | RTC match output for external power control |
| P0[0]/ I2S1RX_CLK | B5 | VDD_IOB | I/O | Port 0 GPIO bit 0 |
| | | | I/O | I ² S1 receive clock |
| P0[1]/ I2S1RX_WS | D7 | VDD_IOB | I/O | Port 0 GPIO bit 1 |
| | | | I/O | I ² S1 receive word select |
| P0[2]/ I2S0RX_SDA/ LCDVD[4] | M17 | VDD_IOA | I/O | Port 0 GPIO bit 2 |
| | | | I/O | I ² S0 receive data |
| | | | I/O | LCD data bit 4 (LPC3230 and LPC3250 only) |

Table 4. Pin description ...continued

| Symbol | Pin | Power supply domain | Type | Description |
|--|-----|---------------------|---------------|--|
| P0[3]/ I2S0RX_CLK/ LCDVD[5] | M18 | VDD_IOA | I/O | Port 0 GPIO bit 3 |
| | | | I/O | I ² S0 receive clock |
| | | | I/O | LCD data bit 5 (LPC3230 and LPC3250 only) |
| P0[4]/ I2S0RX_WS/ LCDVD[6] | L15 | VDD_IOA | I/O | Port 0 GPIO bit 4 |
| | | | I/O | I ² S0 receive word select |
| | | | I/O | LCD data bit 6 (LPC3230 and LPC3250 only) |
| P0[5]/ I2S0TX_SDA/ LCDVD[7] | L16 | VDD_IOA | I/O | Port 0 GPIO bit 5 |
| | | | I/O | I ² S0 transmit data |
| | | | I/O | LCD data bit 7 (LPC3230 and LPC3250 only) |
| P0[6]/ I2S0TX_CLK/ LCDVD[12] | L17 | VDD_IOA | I/O | Port 0 GPIO bit 6 |
| | | | I/O | I ² S0 transmit clock |
| | | | I/O | LCD data bit 12 (LPC3230 and LPC3250 only) |
| P0[7]/ I2S0TX_WS/ LCDVD[13] | L18 | VDD_IOA | I/O | Port 0 GPIO bit 7 |
| | | | I/O | I ² S0 transmit word select |
| | | | I/O | LCD data bit 13 (LPC3230 and LPC3250 only) |
| PLL397_LOOP | R14 | VDD_AD | analog filter | PLL397 loop filter (for external components) |
| PWM_OUT1/ LCDVD[16] | D14 | VDD_IOD | O | PWM1 out |
| | | | O | LCD data bit 16 (LPC3230 and LPC3250 only) |
| PWM_OUT2/INTSTAT/ LCDVD[19] | D15 | VDD_IOD | O | PWM2 output/internal interrupt status ^[1] |
| | | | O | LCD data bit 19 (LPC3230 and LPC3250 only) |
| RESET | M14 | VDD_RTC | I | Reset input, active LOW |
| RESOUT | G4 | VDD_IOC | O | Reset out. Reflects external and WDT reset |
| RTCX_IN | P16 | VDD_RTC | analog in | RTC oscillator input |
| RTCX_OUT | P17 | VDD_RTC | analog out | RTC oscillator output |
| SPI1_CLK/ SCK0 | C9 | VDD_IOD | O | SPI1 clock out |
| | | | O | SSP0 clock out |
| SPI1_DATIN/ MISO0/ GPI_25/ MCI1 | C10 | VDD_IOD | I/O | SPI1 data in |
| | | | I/O | SSP0 MISO |
| | | | I/O | General purpose input bit 25 |
| | | | I | Motor control channel 1 input |
| SPI1_DATIO/ MOSI0/ MCI2 | B9 | VDD_IOD | I/O | SPI1 data out (and optional input) |
| | | | I/O | SSP0 MOSI |
| | | | I | Motor control channel 2 input |
| SPI2_CLK/ SCK1/ LCDVD[23] | B10 | VDD_IOD | I/O | SPI2 clock out |
| | | | I/O | SSP1 clock out |
| | | | I/O | LCD data bit 23 (LPC3230 and LPC3250 only) |
| SPI2_DATIO/ MOSI1/ LCDVD[20] | A9 | VDD_IOD | I/O | SPI2 data out (and optional input) |
| | | | I/O | SSP1 MOSI |
| | | | I/O | LCD data bit 20 (LPC3230 and LPC3250 only) |

Table 4. Pin description ...continued

| Symbol | Pin | Power supply domain | Type | Description |
|---|-----|---------------------|------------|---|
| SPI2_DATIN/ MISO1/ LCDVD[21]/ GPI_27 | A10 | VDD_IOD | I/O | SPI2 data in |
| | | | I/O | SSP1 MISO |
| | | | I/O | LCD data 21 (LPC3230 and LPC3250 only) |
| | | | I/O | General purpose input bit 27 |
| SYSCLKEN/ LCDVD[15] | G17 | VDD_IOD | I/O T | Clock request out for external clock source |
| | | | I/O T | LCD data bit 15 (LPC3230 and LPC3250 only) |
| SYSX_IN | T17 | VDD_AD | analog in | System clock oscillator input |
| SYSX_OUT | R15 | VDD_AD | analog out | System clock oscillator output |
| TS_XP | R13 | VDD_AD | I/O | Touchscreen X output |
| TS_YP | U16 | VDD_AD | I/O | Touchscreen Y output |
| TST_CLK2 | C6 | VDD_IOB | O | Test clock 2 out |
| U1_RX/CAP1[0]/ GPI_15 | K15 | VDD_IOA | I/O | HS UART 1 receive |
| | | | I/O | Timer 1 capture input 0 |
| | | | I/O | General purpose input bit 15 |
| U1_TX | K16 | VDD_IOA | O | HS UART 1 transmit |
| U2_HCTS/ U3_CTS/GPI_16 | J18 | VDD_IOA | I/O | HS UART 2 Clear to Send input |
| | | | I | UART 3 Clear to Send |
| | | | I/O | General purpose input bit 16 |
| U2_RX/ U3_DSR/GPI_17 | K18 | VDD_IOA | I/O | HS UART 2 receive |
| | | | I/O | UART 3 data set ready |
| | | | I/O | General purpose input bit 17 |
| U2_TX/U3_DTR | K17 | VDD_IOA | O | HS UART 2 transmit |
| | | | O | UART 3 data terminal ready out |
| U3_RX/ GPI_18 | J14 | VDD_IOD | I/O | UART 3 receive |
| | | | I/O | General purpose input bit 18 |
| U3_TX | J17 | VDD_IOD | O | UART 3 transmit |
| U5_RX/ GPI_20 | F18 | VDD_IOD | I/O | UART 5 receive |
| | | | I | General purpose input bit 20 |
| U5_TX | H15 | VDD_IOD | O | UART 5 transmit |
| U6_IRRX/ GPI_21 | F17 | VDD_IOD | I/O | UART 6 receive (with IrDA) |
| | | | I | General purpose input bit 21 |
| U6_IRTX | G16 | VDD_IOD | O | UART 6 transmit (with IrDA) |
| U7_HCTS/ CAP0[1]/ LCDCLKIN/ GPI_22 | G13 | VDD_IOD | I | HS UART 7 CTS in |
| | | | I | Timer 0 capture input 1 |
| | | | I | LCD panel clock in (LPC3230 and LPC3250 only) |
| | | | I | General purpose input bit 22 |
| U7_RX/ CAP0[0]/ LCDVD[10]/ GPI_23 | E17 | VDD_IOD | I/O | HS UART 7 receive |
| | | | I/O | Timer 0 capture input 0 |
| | | | I/O | LCD data bit 10 (LPC3230 and LPC3250 only) |
| | | | I/O | General purpose input bit 23 |

Table 4. Pin description ...continued

| Symbol | Pin | Power supply domain | Type | Description |
|---------------------------------|--|---------------------|--------|---|
| U7_TX/ MAT1[1]/ LCDVD[11] | E18 | VDD_IOD | O | HS UART 7 transmit |
| | | | O | Timer 1 match output 1 |
| | | | O | LCD data bit 11 (LPC3230 and LPC3250 only) |
| USB_ATX_INT | C4 | VDD_IOC | I | Interrupt from USB ATX |
| USB_DAT_VP/ U5_RX | D5 | VDD_IOC | I/O: P | USB transmit data, D+ receive |
| | | | I/O: P | UART 5 receive |
| USB_I2C_SCL | E5 | VDD_IOC | I/O T | I ² C clock for USB ATX interface |
| USB_I2C_SDA | E6 | VDD_IOC | I/O T | I ² C data for USB ATX interface |
| USB_OE_TP | D6 | VDD_IOC | I/O | USB transmit enable for DAT/SE0 |
| USB_SE0_VM/ U5_TX | C5 | VDD_IOC | I/O: P | USB single ended zero transmit, D- Receive |
| | | | I/O: P | UART 5 transmit |
| VDD_AD | N12, N13 | VDD_AD | power | 3.3 V supply for ADC/touch screen |
| VDD_CORE | G7, G9, G11, J7, J12, M7, M11 | VDD_CORE | power | 1.2 V or 0.9 V supply for core |
| VDD_COREFXD | L12, M13 | VDD_COREFXD | power | Fixed 1.2 V supply for digital portion of the analog block |
| VDD_EMC | J6, K6, K7, L6, M6, M8, N7, N8, N9, N10, N11 | VDD_EMC | power | 1.8 V or 2.5 V or 3.3 V supply for External Memory Controller (EMC) |
| VDD_IOA | H13, J13 | VDD_IOA | power | 1.8 V or 3.3 V supply for IOA domain |
| VDD_IOB | F8 | VDD_IOB | power | 1.8 V or 3.3 V supply for IOB domain |
| VDD_IOC | F7, G6, H6, J5 | VDD_IOC | power | 1.8 V or 3.3 V supply for IOC domain |
| VDD_IOD | F13, F9 | VDD_IOD | power | 1.8 V to 3.3 V supply for IOD domain |
| VDD_OSC | T18 | VDD_IOD | power | 1.2 V supply for main oscillator |
| VDD_PLL397 | T16 | VDD_PLL397 | power | 1.2 V supply for 397x PLL |
| VDD_PLLHCLK | R17 | VDD_PLLHCLK | power | 1.2 V supply for HCLK PLL |
| VDD_PLLUSB | P15 | VDD_PLLUSB | power | 1.2 V supply for USB PLL |
| VDD_FUSE | N14 | VDD_FUSE | power | 1.2 V supply |

Table 4. Pin description ...continued

| Symbol | Pin | Power supply domain | Type | Description |
|-------------|--|---------------------|-------|---------------------------------|
| VDD_RTC | K14 | VDD_RTC | power | 1.2 V supply for RTC I/O |
| VDD_RTCCORE | L13 | VDD_RTCCORE | power | 1.2 V supply for RTC |
| VDD_RTCOSC | N15 | VDD_RTCOSC | power | 1.2 V supply for RTC oscillator |
| VSS_AD | P13 | - | power | Ground for ADC/touch screen |
| VSS_CORE | G8, G10, G12, H7, K12, L7, M9, M10, M12 | - | power | Ground for core |
| VSS EMC | K5, L5, M5, N5, N6, P6, P7, P8, P9, P10, P11 | - | power | Ground for EMC |
| VSS_IOA | K13 | - | power | Ground VDD_IOA domain |
| VSS_IOB | F6 | - | power | Ground VDD_IOB domain |
| VSS_IOC | F5, G5, H5 | - | power | Ground VDD_IOC domain |
| VSS_IOD | F10, F11, F12, H12 | - | power | Ground VDD_IOD domain |
| VSS_OSC | P14 | - | power | Ground for main oscillator |
| VSS_PLL397 | T15 | - | power | Ground for 397x PLL |
| VSS_PLLHCLK | R18 | - | power | Ground for HCLK PLL |
| VSS_PLLUSB | R16 | - | power | Ground for USB PLL |
| VSS_RTCCORE | L14 | - | power | Ground for RTC |
| VSS_RTCOSC | P18 | - | power | Ground for RTC oscillator |

[1] The PWM2_CTRL register controls this pin function (see *LPC32x0 User manual*).

Table 5. Digital I/O pad types^[1]

| Parameter | Abbreviation |
|------------|---|
| I/O type | I = input. O = output. I/O = bidirectional. I/O T = bidirectional or high impedance. |
| Pin detail | BK: pin has a bus keeper function that weakly retains the last level driven on an I/O pin when it is switched from output to input. PU: pin has a nominal 50 µA internal pull-up connected. PD: pin has a nominal 50 µA internal pull-down connected. P: pin has programmable input characteristics. |

[1] See *LPC32x0 User manual* for details.

Table 6. Supply domains

| Supply domain | Voltage range | Related supply pins | Description |
|------------------------|---|--|--|
| VDD_CORE | 0.9 V to 1.39 V | VDD_CORE | Core power domain. |
| VDD_COREFXD | 1.2 V | VDD_COREFXD | Fixed 1.2 V supply for digital portion of the analog block. |
| other core domains | 1.2 V | VDD_PLL397, VDD_PLLHCLK, VDD_PLLUSB, VDD_FUSE | 1.2 V supplies, tied to VDD_COREFXD. |
| VDD_RTC | 0.9 V to 1.39 V | VDD_RTC, VDD_RTCCORE, VDD_RTCOSC | RTC supply domain. Can be connected to a battery backed-up power source. |
| VDD_AD | 2.7 V to 3.6 V | VDD_AD | 3.3 V supply for ADC and touch screen. |
| VDD EMC | 1.7 V to 1.95 V 2.3 V to 2.7 V 2.7 V to 3.6 V | VDD EMC | External memory interface IO pins in 1.8 V range, 2.5 V range, or 3.3 V range. |
| VDD_IOA ^[1] | 1.7 V to 1.95 V or 2.7 V to 3.6 V | VDD_IOA | Peripheral supply. |
| VDD_IOB ^[1] | 1.7 V to 1.95 V or 2.7 V to 3.6 V | VDD_IOB | Peripheral supply. |
| VDD_IOC ^[1] | 1.7 V to 1.95 V or 2.3 V to 3.6 V | VDD_IOC | Peripheral supply. |
| VDD_IOD ^[1] | 1.7 V to 1.95 V or 2.7 V to 3.6 V | VDD_IOD | Peripheral supply. |

[1] The VDD_IOA, VDD_IOB, VDD_IOC, and VDD_IOD supply domains can be operated at a voltage independent of the other domains as long as all pins connected to the same peripheral are at the same voltage level. There are two special cases for determining supply domain voltages (for details see *application note AN10777*):

- a) Ethernet configured in MII mode: VDD_IOD must be the same as VDD_IOB.
- b) UART3 when used with hardware flow control or when sharing an RS-232 transceiver with another UART: VDD_IOA must be the same as VDD_IOD.

7. Functional description

7.1 CPU and subsystems

7.1.1 CPU

NXP created the LPC3220/30/40/50 using an ARM926EJ-S CPU core that includes a Harvard architecture and a 5-stage pipeline. To this ARM core, NXP implemented a 32 kB instruction cache, a 32 kB data cache and a Vector Floating Point coprocessor. The ARM926EJ-S core also has an integral Memory Management Unit (MMU) to provide the virtual memory capabilities required to support the multi-programming demands of modern operating systems. The basic ARM926EJ-S core V5TE instruction set includes DSP instruction extensions for native Jazelle Java Byte-code execution in hardware. The LPC3220/30/40/50 operates at CPU frequencies up to 266 MHz.

7.1.2 Vector Floating Point (VFP) coprocessor

The LPC3220/30/40/50 includes a VFP co-processor providing full support for single-precision and double-precision add, subtract, multiply, divide, and multiply-accumulate operations at CPU clock speeds. It is compliant with the IEEE 754 standard for binary Floating-Point Arithmetic. This hardware floating point capability makes the microcontroller suitable for advanced motor control and DSP applications. The VFP has 3 separate pipelines for floating-point MAC operations, divide or square root operations, and Load/Store operations. These pipelines operate in parallel and can complete execution out of order. All single-precision instructions execute in one cycle, except the divide and square root instructions. All double-precision multiply and multiply-accumulate instructions take two cycles. The VFP also provides format conversions between floating-point and integer word formats.

7.1.3 Emulation and debugging

The LPC3220/30/40/50 supports emulation and debugging via a dedicated JTAG serial port. An Embedded Trace Buffer allows tracing program execution. The dedicated JTAG port allows debugging of all chip features without impact to any pins that may be used in the application.

7.1.3.1 Embedded ICE

Standard ARM EmbeddedICE logic provides on-chip debug support. The debugging of the target system requires a host computer running the debugger software and an Embedded ICE protocol converter. The Embedded ICE protocol converter converts the Remote Debug Protocol commands to the JTAG data needed to access the ARM core.

The ARM core has a Debug Communication Channel (DCC) function built-in. The debug communication channel allows a program running on the target to communicate with the host debugger or another separate host without stopping the program flow or entering the debug state.

7.1.3.2 Embedded trace buffer

The Embedded Trace Module (ETM) is connected directly to the ARM core. It compresses the trace information and exports it through a narrow trace port. An internal Embedded Trace Buffer (ETB) of 2048×24 bits captures the trace information under software debugger control. Data from the ETB is recovered by the debug software through the JTAG port.

The trace contains information about when the ARM core switches between states. Instruction shows the flow of execution of the processor and provides a list of all the instructions that were executed. Instruction trace is significantly compressed by only broadcasting branch addresses as well as a set of status signals that indicate the pipeline status on a cycle by cycle basis. For data accesses either data or address or both can be traced.

7.2 AHB matrix

The LPC3220/30/40/50 has a multi-layer AHB matrix for inter-block communication. AHB is an ARM defined high-speed bus, which is part of the ARM bus architecture. AHB is a high-bandwidth low-latency bus that supports multi-master arbitration and a bus grant/request mechanism. For systems that have only one (CPU), or two (CPU and DMA) bus masters a simple AHB works well. However, if a system requires multiple bus masters and the CPU needs access to external memory, a single AHB bus can cause a bottleneck.

To increase performance, the LPC3220/30/40/50 uses an expanded AHB architecture known as Multi-layer AHB. A Multi-layer AHB replaces the request/grant and arbitration mechanism used in a simple AHB with an interconnect matrix that moves arbitration out toward the slave devices. Thus, if a CPU and a DMA controller want access to the same memory, the interconnect matrix arbitrates between the two when granting access to the memory. This advanced architecture allows simultaneous access by bus masters to different resources with an increase in arbitration complexity. In this architectural implementation, removing guaranteed central arbitration and allowing more than one bus master to be active at the same time provides better overall microcontroller performance.

In the LPC3220/30/40/50, the multi-Layer AHB system has a separate bus for each of seven AHB Masters:

- CPU data bus
- CPU instruction bus
- General purpose DMA Master 0
- General purpose DMA Master 1
- Ethernet controller
- USB controller
- LCD controller

There are no arbitration delays unless two masters attempt to access the same slave at the same time.

7.2.1 APB

Many peripheral functions are accessed by on-chip APBs that are attached to the higher speed AHB. The APB performs reads and writes to peripheral registers in three peripheral clocks.

7.2.2 FAB

Some peripherals are placed on a special bus called FAB that allows faster CPU access to those peripheral functions. A write access to FAB peripherals takes a single AHB clock and a read access to FAB peripherals takes two AHB clocks.

7.3 Physical memory map

The physical memory map incorporates several distinct regions, as shown in [Figure 3](#). When an application is running, the CPU interrupt vectors are re-mapped to allow them to reside in on-chip SRAM (IRAM).

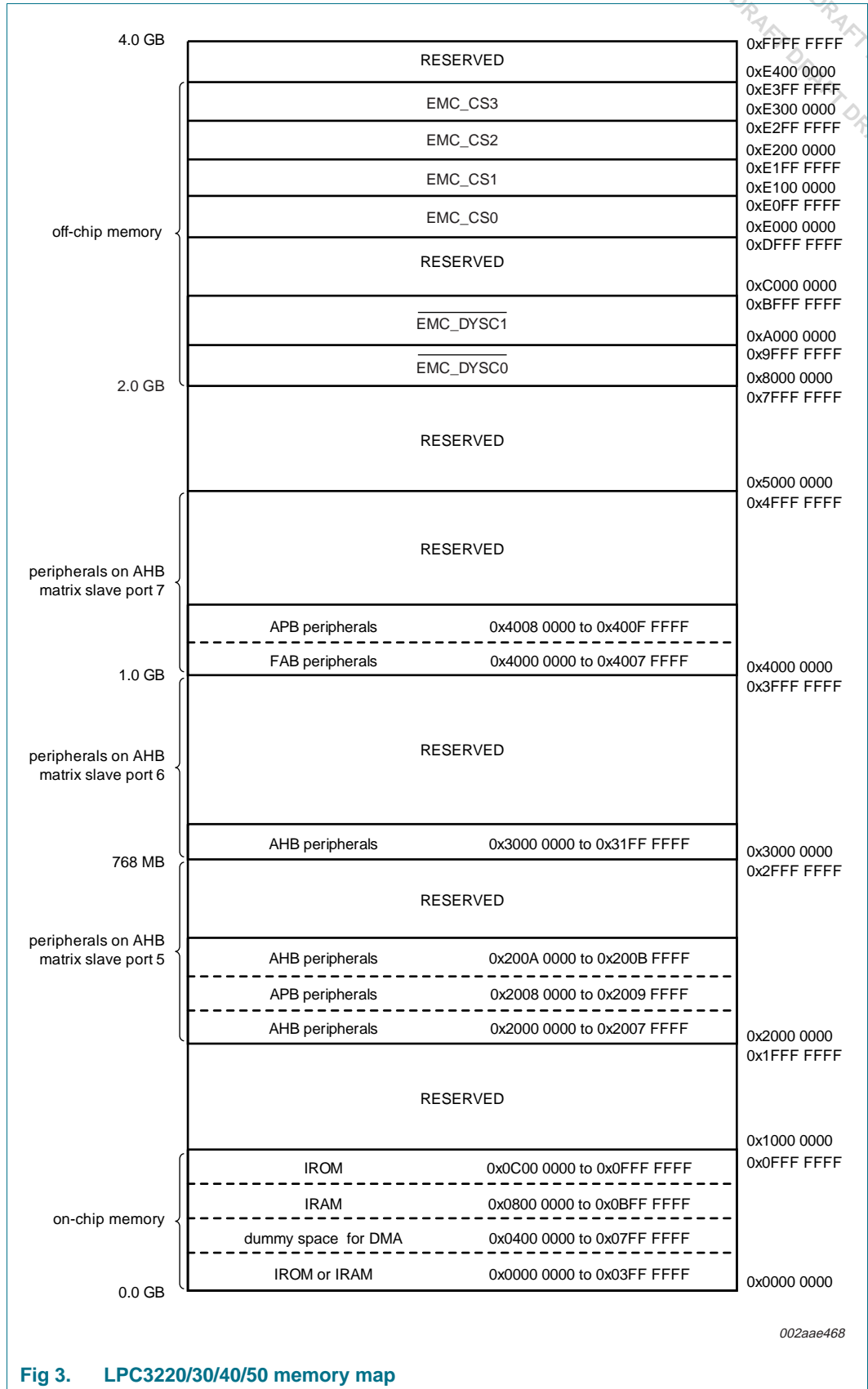

Fig 3. LPC3220/30/40/50 memory map

7.4 Internal memory

7.4.1 On-chip ROM

The built-in 16 kB ROM contains a program which runs a boot procedure to load code from one of four external sources, UART5, SSP0 (SPI mode), EMC Static CS0 memory, or NAND FLASH.

After reset, execution always begins from the internal ROM. The bootstrap software first reads the $\overline{\text{SERVICE}}$ input (GPI_1). If $\overline{\text{SERVICE}}$ is LOW, the bootstrap starts a service boot and can download a program over serial link UART5 to IRAM and transfer execution to the downloaded code.

If the $\overline{\text{SERVICE}}$ pin is HIGH, the bootstrap routine jumps to normal boot. The normal boot process first tests SPI memory for boot information if present it uploads the boot code and transfers execution to the uploaded software. If the SPI is not present or no software is loaded, the boot loader will test the EMC Static CS0 memory for the presence of boot code and if present boots from static memory, If this test fails the boot loader will test external NAND flash for boot code and boot if code is present.

The boot loader consumes no user memory space because it is in ROM.

7.4.2 On-chip SRAM

On-chip SRAM may be used for code and/or data storage. The SRAM may be accessed as 8, 16, or 32 bit memory. The LPC3220/30/40/50 provides 256 kB of internal SRAM.

7.5 External memory interfaces

The LPC3220/30/40/50 includes three external memory interfaces, NAND Flash controllers, Secure Digital Memory Controller, and an external memory controller for SDRAM, DDR SDRAM, and Static Memory devices.

7.5.1 NAND flash controllers

The LPC3220/30/40/50 includes two NAND flash controllers, one for multi-level cell NAND flash devices and one for single-level cell NAND flash devices. The two NAND flash controllers use the same pins to interface to external NAND flash devices, so only one interface is active at a time.

7.5.1.1 Multi-Level Cell (MLC) NAND flash controller

The MLC NAND flash controller interfaces to either multi-level or single-level NAND flash devices. An external NAND flash device is used to allow the bootloader to automatically load a portion of the application code into internal SRAM for execution following reset.

The MLC NAND flash controller supports small (528 byte) and large (2114 byte) pages. Programmable NAND timing parameters allow support for a variety of NAND flash devices. A built-in Reed-Solomon encoder/decoder provides error detection and correction capability. A 528 byte data buffer reduces the need for CPU supervision during loading. The MLC NAND flash controller also provides DMA support.

7.5.1.2 Single-Level Cell (SLC) NAND flash controller

The SLC NAND flash controller interfaces to single-level NAND flash devices. DMA page transfers are supported, including a 20-byte DMA read and write FIFO. Hardware support for ECC (Error Checking and Correction) is included for the main data area. Software can correct a single bit error.

7.5.2 SD card controller

The SD interface allows access to external SD memory cards. The SD card interface conforms to the *SD Memory Card Specification Version 1.01*.

7.5.2.1 Features

- 1-bit and 4-bit data line interface support.
- DMA is supported through the system DMA controller.
- Provides all functions specific to the SD memory card. These include the clock generation unit, power management control, command and data transfer.

7.5.3 External memory controller

The LPC3220/30/40/50 includes a memory controller that supports data bus SDRAM, DDR SDRAM, and static memory devices. The memory controller provides an interface between the system bus and external (off-chip) memory devices.

The controller supports 16-bit and 32-bit wide SDR SDRAM devices of 64 Mbit, 128 Mbit, 128 Mbit, 256 Mbit, and 512 Mbit sizes, as well as 16-bit wide data bus DDR SDRAM devices of 64 Mbit, 128 Mbit, 128 Mbit, 256 Mbit, and 512 Mbit sizes. Two dynamic memory chip selects are supplied, supporting two groups of SDRAM:

- DYCS0 in the address range 0x8000 0000 to 0x9FFF FFFF
- DYCS1 in the address range 0xA000 0000 to 0xBFFF FFFF

The memory controller also supports 8-bit, 16-bit, and 32-bit wide asynchronous static memory devices, including RAM, ROM, and flash, with or without asynchronous page mode. Four static memory chip selects are supplied for SRAM devices:

- CS0 in the address range 0xE000 0000 to 0xE0FF FFFF
- CS1 in the address range 0xE100 0000 to 0xE1FF FFFF
- CS2 in the address range 0xE200 0000 to 0xE2FF FFFF
- CS3 in the address range 0xE300 0000 to 0xE3FF FFFF

The SDRAM controller uses three data ports to allow simultaneous requests from multiple on-chip AHB bus masters and has the following features.

- Dynamic memory interface supports SDRAM, DDR-SDRAM, and low-power variants.
- Read and write buffers to reduce latency and improve performance.
- Static memory features include
 - asynchronous page mode read
 - programmable wait states
 - bus turnaround cycles
 - output enable and write enable delays

- extended wait
- Power-saving modes dynamically control EMC_CKE[1:0] and EMC_CLK.
- Dynamic memory self-refresh mode supported by software.
- Controller supports 2 k, 4 k, and 8 k row address synchronous memory parts. That is, typical 512 MB, 256 MB, 128 MB, and 16 MB parts, with 8, 16, or 32 data bits per device.
- Two reset domains enable dynamic memory contents to be preserved over a soft reset.
- This controller does not support synchronous static memory devices (burst mode devices).

7.6 AHB master peripherals

The LPC3220/30/40/50 implements four AHB master peripherals, which include a General Purpose Direct Memory Access (GPDMA) controller, a 10/100 Ethernet Media Access Controller (MAC), a Universal Serial Bus (USB) controller, and an LCD controller. Each of these four peripherals contain an integral DMA controller optimized to support the performance demands of the peripheral.

7.6.1 General Purpose DMA (GPDMA) controller

The GPDMA controller allows peripheral-to memory, memory-to-peripheral, peripheral-to-peripheral, and memory-to-memory transactions. Each DMA stream provides unidirectional serial DMA transfers for a single source and destination. For example, a bidirectional port requires one stream for transmit and one for receive. The source and destination areas can each be either a memory region or a peripheral, and can be accessed through the same AHB master, or one area by each master. The DMA controller supports the following peripheral device transfers.

- Secure Digital (SD) Memory interface
- High-speed UARTs
- I²S0 and I²S1 ports
- SPI1 and SPI2 interfaces
- SSP0 and SSP1 interfaces
- Memory

The DMA controls eight DMA channels with hardware prioritization. The DMA controller interfaces to the system via two AHB bus masters, each with a full 32-bit data bus width. DMA operations may be set up for 8-bit, 16-bit, and 32-bit data widths, and can be either big-endian or little-endian. Incrementing or non-incrementing addressing for source and destination are supported, as well as programmable DMA burst size. Scatter or gather DMA is supported through the use of linked lists. This means that the source and destination areas do not have to occupy contiguous areas of memory.

7.6.2 Ethernet MAC

The Ethernet block contains a full featured 10 Mbit/s or 100 Mbit/s Ethernet MAC designed to provide optimized performance through the use of DMA hardware acceleration. Features include a generous suite of control registers, half or full duplex operation, flow control, control frames, hardware acceleration for transmit retry, receive

packet filtering and wake-up on LAN activity. Automatic frame transmission and reception with scatter-gather DMA off-loads many operations from the CPU. The Ethernet DMA can access off-chip memory via the EMC, as well as the IRAM. The Ethernet block interfaces between an off-chip Ethernet PHY using the Media Independent Interface (MII) or Reduced MII (RMII) protocol and the on-chip Media Independent Interface Management (MIIM) serial bus.

7.6.2.1 Features

- Ethernet standards support:
 - Supports 10 Mbit/s or 100 Mbit/s PHY devices including 10 Base-T, 100 Base-TX, 100 Base-FX, and 100 Base-T4.
 - Fully compliant with IEEE standard 802.3.
 - Fully compliant with 802.3x Full Duplex Flow Control and Half Duplex back pressure.
 - Flexible transmit and receive frame options.
 - Virtual Local Area Network (VLAN) frame support.
- Memory management:
 - Independent transmit and receive buffers memory mapped to SRAM.
 - DMA managers with scatter/gather DMA and arrays of frame descriptors.
 - Memory traffic optimized by buffering and pre-fetching.
- Enhanced Ethernet features:
 - Receive filtering.
 - Multicast and broadcast frame support for both transmit and receive.
 - Optional automatic Frame Check Sequence (FCS) insertion with Circular Redundancy Check (CRC) for transmit.
 - Selectable automatic transmit frame padding.
 - Over-length frame support for both transmit and receive allows any length frames.
 - Promiscuous receive mode.
 - Automatic collision back-off and frame retransmission.
 - Includes power management by clock switching. Wake-on-LAN power management support allows system wake-up using the receive filters or a magic frame detection filter.
- Physical interface
 - Attachment of external PHY chip through standard MII or RMII interface.
 - PHY register access is available via the MIIM interface.

7.6.3 USB interface

The LPC3220/30/40/50 supports USB in either device, host, or OTG configuration.

7.6.3.1 USB device controller

The USB device controller enables 12 Mbit/s data exchange with a USB host controller. It consists of register interface, serial interface engine, endpoint buffer memory and DMA controller. The serial interface engine decodes the USB data stream and writes data to the appropriate end point buffer memory. The status of a completed USB transfer or error

condition is indicated via status registers. An interrupt is also generated if enabled. The DMA controller when enabled transfers data between the endpoint buffer and the USB RAM.

Features

- Fully compliant with *USB 2.0 full-speed specification*.
- Supports 32 physical (16 logical) endpoints.
- Supports control, bulk, interrupt and isochronous endpoints.
- Scalable realization of endpoints at run time.
- Endpoint maximum packet size selection (up to USB maximum specification) by software at run time.
- RAM message buffer size based on endpoint realization and maximum packet size.
- Supports bus-powered capability with low suspend current.
- Supports DMA transfer on all non-control endpoints.
- One duplex DMA channel serves all endpoints.
- Allows dynamic switching between CPU controlled and DMA modes.
- Double buffer implementation for bulk and isochronous endpoints.

7.6.3.2 USB host controller

The host controller enables data exchange with various USB devices attached to the bus. It consists of register interface, serial interface engine and DMA controller. The register interface complies to the *OHCI specification*.

Features

- OHCI compliant.
- OHCI specifies the operation and interface of the USB host controller and software driver.
- The host controller has four USB states visible to the software driver:
 - USBOperational: Process lists and generate SOF tokens.
 - USBReset: Forces reset signaling on the bus, SOF disabled.
 - USBSuspend: Monitor USB for wake-up activity.
 - USBResume: Forces resume signaling on the bus.
- HCCA register points to interrupt and isochronous descriptors list.
- ControlHeadED and BulkHeadED registers point to control and bulk descriptors list.

7.6.3.3 USB OTG controller

USB OTG (On-The-Go) is a supplement to the *USB 2.0 specification* that augments the capability of existing mobile devices and USB peripherals by adding host functionality for connection to USB peripherals.

Features

- Fully compliant with *On-The-Go supplement to the USB Specification 2.0 Revision 1.0*.

- Supports Host Negotiation Protocol (HNP) and Session Request Protocol (SRP) for dual-role devices under software control. HNP is partially implemented in hardware.
- Provides programmable timers required for HNP and SRP.
- Supports slave mode operation through AHB slave interface.
- Supports the OTG ATX from NXP (ISP 1302) or any external CEA-2011OTG specification compliant ATX.

7.6.4 LCD controller

The LCD controller provides all of the necessary control signals to interface directly to a variety of color and monochrome LCD panels. Both STN (single and dual panel) and TFT panels can be operated. The display resolution is selectable and can be up to 1024 × 768 pixels. Several color modes are provided, up to a 24-bit true-color non-palettized mode.

An on-chip 512-byte color palette allows reducing bus utilization (i.e. memory size of the displayed data) while still supporting a large number of colors.

The LCD interface includes its own DMA controller to allow it to operate independently of the CPU and other system functions. A built-in FIFO acts as a buffer for display data, providing flexibility for system timing. Hardware cursor support can further reduce the amount of CPU time needed to operate the display.

7.6.4.1 Features

- AHB bus master interface to access frame buffer.
- Setup and control via a separate AHB slave interface.
- Dual 16-deep programmable 64-bit wide FIFOs for buffering incoming display data.
- Supports single and dual-panel monochrome Super Twisted Nematic (STN) displays with 4-bit or 8-bit interfaces.
- Supports single and dual-panel color STN displays.
- Supports Thin Film Transistor (TFT) color displays.
- Programmable display resolution including, but not limited to: 320 × 200, 320 × 240, 640 × 200, 640 × 240, 640 × 480, 800 × 600, and 1024 × 768.
- Hardware cursor support for single-panel displays.
- 15 gray-level monochrome, 3375 color STN, and 32 k color palettized TFT support.
- 1, 2, or 4 bits-per-pixel (bpp) palettized displays for monochrome STN.
- 1, 2, 4, or 8 bpp palettized color displays for color STN and TFT.
- 16 bpp true-color non-palettized, for color STN and TFT.
- 24 bpp true-color non-palettized, for color TFT.
- Programmable timing for different display panels.
- 256 entry, 16-bit palette RAM, arranged as a 128 × 32 bit RAM.
- Frame, line, and pixel clock signals.
- AC bias signal for STN, data enable signal for TFT panels.
- Supports little and big-endian, and Windows CE data formats.
- LCD panel clock may be generated from the peripheral clock or from a clock input pin.

7.7 System functions

To enhance the performance of the LPC3220/30/40/50 incorporates the following system functions, an Interrupt Controller (INTC), a watchdog timer, a millisecond timer, and several power control features. These functions are described in the following sections

7.7.1 Interrupt controller

The interrupt controller is comprised of three basic interrupt controller blocks, supporting a total of 73 interrupt sources. Each interrupt source can be individually enabled/disabled and configured for high or low level triggering, or rising or falling edge triggering. Each interrupt may also be steered to either the FIQ or IRQ input of the ARM9. Raw interrupt status and masked interrupt status registers allow versatile condition evaluation. In addition to peripheral functions, each of the six general purpose input/output pins and 12 of the 22 general purpose input pins are connected directly to the interrupt controller.

7.7.2 Watchdog timer

The watchdog timer block is clocked by the main peripheral clock, which clocks a 32-bit counter. A match register is compared to the Timer. When configured for watchdog functionality, a match drives the match output low. The match output is gated with an enable signal that gives the opportunity to generate two type of reset signal: one that only resets chip internally, and another that goes through a programmable pulse generator before it goes to the external pin $\overline{\text{RESOUT}}$ and to the internal chip reset.

7.7.2.1 Features

- Programmable 32-bit timer.
- Internally resets the device if not periodically reloaded.
- Flag to indicate that a watchdog reset has occurred.
- Programmable watchdog pulse output on $\overline{\text{RESOUT}}$ pin.
- Can be used as a standard timer if watchdog is not used.
- Pause control to stop counting when core is in debug state.

7.7.3 Millisecond timer

The millisecond timer is clocked by 32 kHz RTC clock, so a prescaler is not needed to obtain a lower count rate.

The millisecond timer includes three match registers that are compared to the Timer/Counter value. A match can generate an interrupt and the cause the Timer/Counter either continue to run, stop, or be reset.

7.7.3.1 Features

- 32-bit Timer/Counter, running from the 32 kHz RTC clock.
- Counter or Timer operation.
- Three 32-bit match registers that allow:
 - Continuous operation with optional interrupt generation on match.
 - Stop timer on match with optional interrupt generation.
 - Reset timer on match with optional interrupt generation.
- Pause control to stop counting when core is in debug state.

7.7.4 Clocking and power control features

7.7.4.1 Clocking

Clocking in the LPC3220/30/40/50 is designed to be versatile, so that system and peripheral requirements may be met, while allowing optimization of power consumption. Clocks to most functions may be turned off if not needed and some peripherals do this automatically.

The LPC3220/30/40/50 supports three operational modes, two of which are specifically designed to reduce power consumption. The modes are: Run mode, Direct run mode, and Stop mode. These three operational modes give control over processing speed and power consumption. In addition, clock rates to different functional blocks may be changed by switching clock sources, changing PLL values, or altering clock divider configurations. This allows a trade-off of power versus processing speed based on application requirements.

7.7.4.2 Crystal oscillator

The main oscillator is the basis for the clocks most chip functions use by default. Optionally, many functions can be clocked instead by the output of a PLL (with a fixed 397x rate multiplication) which runs from the RTC oscillator. In this mode, the main oscillator may be turned off unless the USB interface is enabled. If a SYSCLK frequency other than 13 MHz is required in the application, or if the USB block is not used, the main oscillator may be used with a frequency of between 1 MHz and 20 MHz.

7.7.4.3 PLLs

The LPC3220/30/40/50 includes three PLLs: The 397x PLL allows boosting the RTC frequency to 13.008896 MHz for use as the primary system clock. The USB PLL provides the 48 MHz clock required by the USB block, and the HCLK PLL provides the basis for the CPU clock, the AHB bus clock, and the main peripheral clock.

The 397x PLL multiplies the 32768 Hz RTC clock by 397 to obtain a 13.008896 MHz clock. The 397x PLL is designed for low power operation and low jitter. This PLL requires an external RC loop filter for proper operation.

The HCLK PLL accepts an input clock from either the main oscillator or the output of the 397x PLL. The USB PLL only accepts an input clock from the main oscillator. The USB input clock runs through a divide-by-N pre-divider before entering the USB PLL.

The input to the HCLK and USB PLLs may initially be divided down by a pre-divider value 'N', which may have the values 1, 2, 3, or 4. This pre-divider can allow a greater number of possibilities for the output frequency. Following the PLL input divider is the PLL multiplier. This can multiply the pre-divider output by a value 'M', in the range of 1 through 256. The resulting frequency must be in the range of 156 MHz to 320 MHz. The multiplier works by dividing the output of a Current Controlled Oscillator (CCO) by the value of M, then using a phase detector to compare the divided CCO output to the pre-divider output. The error value is used to adjust the CCO frequency.

At the PLL output, there is a post-divider that can be used to bring the CCO frequency down to the desired PLL output frequency. The post-divider value can divide the CCO output by 1, 2, 4, 8, or 16. The post-divider can also be bypassed, allowing the PLL CCO

output to be used directly. The maximum PLL output frequency supported by the CPU is 266 MHz. The only output frequency supported by the USB PLL is 48 MHz, and the clock has strict requirements for nominal frequency (500 ppm) and jitter (500 ps).

7.7.4.4 Power control modes

The LPC3220/30/40/50 supports three operational modes, two of which are specifically designed to reduce power consumption. The modes are: Run mode, Direct Run mode, and Stop mode.

Run mode is the normal operating mode for applications that require the CPU, AHB bus, or any peripheral function other than the USB block to run faster than the main oscillator frequency. In Run mode, the CPU can run at up to 266 MHz and the AHB bus can run at up to 133 MHz.

Direct Run mode allows reducing the CPU and AHB bus rates in order to save power. Direct Run mode can also be the normal operating mode for applications that do not require the CPU, AHB bus, or any peripheral function other than the USB block to run faster than the main oscillator frequency. Direct Run mode is the default mode following chip reset.

Stop mode causes all CPU and AHB operation to cease, and stops clocks to peripherals other than the USB block.

7.7.4.5 Reset

Reset is accomplished by an active LOW signal on the $\overline{\text{RESET}}$ input pin. A reset pulse with a minimum width of 10 main oscillator clocks after the oscillator is stable is required to guarantee a valid chip reset. At power-up, 10 milliseconds should be allowed for the oscillator to start up and stabilize after V_{DD} reaches operational voltage. An internal reset with a minimum duration of 10 clock pulses will also be applied if the watchdog timer generates an internal device reset.

The $\overline{\text{RESET}}$ pin is located in the RTC power domain. This means that the RTC power must be present for an external reset to have any effect. The RTC power domain nominally runs from 1.2 V, but the $\overline{\text{RESET}}$ pin can be driven as high as 1.95 V.

7.8 Communication peripheral interfaces

In addition to the Ethernet MAC and USB interfaces there are many more serial communication peripheral interfaces available on the LPC3220/30/40/50. Here is a list of the serial communication interfaces:

- Seven UARTs; four standard UARTs and three high-speed UARTs
- Two SPI serial I/O controllers
- Two SSP serial I/O controllers
- Two I²C serial I/O controllers
- Two I²S audio controllers

A short functional description of each of these peripherals is provided in the following sections.

7.8.1 UARTs

The LPC3220/30/40/50 contains seven UARTs. Four are standard UARTs, and three are high-speed UARTs.

7.8.1.1 Standard UARTs

The four standard UARTs are compatible with the INS16Cx50. These UARTs support rates up to 460800 bit/s from a 13 MHz peripheral clock.

Features

- Each standard UART has 64 byte Receive and Transmit FIFOs.
- Receiver FIFO trigger points at 16, 32, 48, and 60 Bytes.
- Transmitter FIFO trigger points at 0, 4, 8, and 16 Bytes.
- Register locations conform to the "550" industry standard.
- Each standard UART has a fractional rate pre-divider and an internal baud rate generator.
- The standard UARTs support three clocking modes: on, off, and auto-clock. The auto-clock mode shuts off the clock to the UART when it is idle.
- UART 6 includes an IrDA mode to support infrared communication.
- The standard UARTs are designed to support data rates of (2400, 4800, 9600, 19200, 38400, 57600, 115200, 230400, 460800) bit/s.
- Each UART includes an internal loopback mode.

7.8.1.2 High-speed UARTs

The three high-speed UARTs are designed to support rates up to 921600 bit/s from a 13 MHz peripheral clock for on-board communication in low noise conditions. This is accomplished by changing the over sampling from 16 \times to 14 \times and altering the rate generation logic.

Features

- Each high-speed UART has 64-byte Receive and Transmit FIFOs.
- Receiver FIFO trigger points at 1, 4, 8, 16, 32, and 48 B.
- Transmitter FIFO trigger points at 0, 4, and 8 B.
- Each high-speed UART has an internal baud rate generator.
- The high-speed UARTs are designed to support data rates of (2400, 4800, 9600, 19200, 38400, 57600, 115200, 230400, 460800, 921600) bit/s.
- The three high speed UARTs only support (8N1) 8-bit data word length, 1-stop bit, no parity, and no flow control as a the communications protocol.
- Each UART includes an internal loopback mode.

7.8.2 SPI serial I/O controller

The LPC3220/30/40/50 has two Serial Peripheral Interfaces (SPI). The SPI is a 3-wire serial interface that is able to interface with a large range of serial peripheral or memory devices (SPI mode 0 to 3 compatible slave devices).

Only a single master and a single slave can communicate on the interface during a given data transfer. During a data transfer the master always sends a byte of data to the slave, and the slave always sends a byte of data to the master. The SPI implementation on the LPC3220/30/40/50 does not support operation as a slave.

7.8.2.1 Features

- Supports slaves compatible with SPI modes 0 to 3.
- Half duplex synchronous transfers.
- DMA support for data transmit and receive.
- 1-bit to 16-bit word length.
- Choice of LSB or MSB first data transmission.
- 64 × 16-bit input or output FIFO.
- Bit rates up to 52 Mbit/s.
- Busy input function.
- DMA time out interrupt to allow detection of end of reception when using DMA.
- Timed interrupt to facilitate emptying the FIFO at the end of a transmission.
- SPI clock and data pins may be used as general purpose pins if the SPI is not used.
- Slave selects can be supported using GPO or GPIO pins

7.8.3 SSP serial I/O controller

The LPC3220/30/40/50 contains two SSP controllers. The SSP controller is capable of operation on a SPI, 4-wire SSI, or Microwire bus. It can interact with multiple masters and slaves on the bus. Only a single master and a single slave can communicate on the bus during a given data transfer. The SSP supports full duplex transfers, with frames of 4 bits to 16 bits of data flowing from the master to the slave and from the slave to the master. In practice, often only one of these data flows carries meaningful data.

7.8.3.1 Features

- Compatible with Motorola SPI, 4-wire TI SSI, and National Semiconductor Microwire buses
- Synchronous serial communication
- Master or slave operation
- 8-frame FIFOs for both transmit and receive
- 4-bit to 16-bit frame
- Maximum SPI bus data bit rate of $\frac{1}{2}$ (Master mode) and $\frac{1}{12}$ (Slave mode) of the input clock rate
- DMA transfers supported by GPDMA

7.8.4 I²C-bus serial I/O controller

There are two I²C-bus interfaces in the LPC32x0 family of controllers. These I²C blocks can be configured as a master, multi-master or slave supporting up to 400 kHz. The I²C blocks also support 7 or 10 bit addressing. Each has a four word FIFO for both transmit and receive. An interrupt signal is available from each block.

There is a separate slave transmit FIFO. The slave transmit FIFO (TXS) and its level are only available when the controller is configured as a Master/Slave device and is operating in a multi-master environment. Separate TX FIFOs are needed in a multi-master because a controller might have a message queued for transmission when an external master addresses it to become a slave-transmitter, a second source of data is needed.

Note that the I²C clock must be enabled in the I2CCLK_CTRL register before using the I²C. The I²C clock can be disabled between communications, if used as a single master I²C-bus interface, software has full control of when I²C communication is taking place on the bus.

7.8.4.1 Features

- The two I²C-bus blocks are standard I²C-bus compliant interfaces that may be used in Single-master, Multi-master or Slave modes.
- Programmable clock to allow adjustment of I²C-bus transfer rates.
- Bidirectional data transfer.
- Serial clock synchronization allows devices with different bit rates to communicate via one serial bus.
- Serial clock synchronization can be used as a handshake mechanism to suspend and resume serial transfer.

7.8.5 I²S-bus audio controller

The I²S-bus provides a standard communication interface for digital audio applications. The I²S-bus specification defines a 3-wire serial bus using one data line, one clock line, and one word select signal. Each I²S connection can act as a master or a slave. The master connection determines the frequency of the clock line and all other slaves are driven by this clock source. The two I²S-bus interfaces on the LPC3220/30/40/50 provides a separate transmit and receive channel, providing a total of two transmit channels and two receive channels. Each I²S channel supports monaural or stereo formatted data.

7.8.5.1 Features

- The interface has separate input/output channels each of which can operate in master or slave mode.
- Capable of handling 8-bit, 16-bit, and 32-bit word sizes.
- Mono and stereo audio data supported.
- Supports standard sampling frequencies (8 kHz, 11.025 kHz, 16 kHz, 22.05 kHz, 32 kHz, 44.1 kHz, 48 kHz, 96 kHz).
- Word select period can be configured in master mode (separately for I²S input and output).
- Two eight-word FIFO data buffers are provided, one for transmit and one for receive.
- Generates interrupt requests when buffer levels cross a programmable boundary.
- Two DMA requests, controlled by programmable buffer levels. These are connected to the GPDMA block.
- Controls include reset, stop, and mute options separately for I²S input and I²S output.

7.9 Other peripherals

In addition to the communication peripherals there are many general purpose peripherals available in the LPC3220/30/40/50. Here is a list of the general purpose peripherals.

- GPIO
- Keyboard scanner
- Touch screen controller and 10-bit Analog-to-Digital-Converter
- Real-time clock
- High-speed timer
- Four general purpose 32-bit timer/external event counters
- Two simple PWMs
- One motor control PWM

A short functional description of each of these peripherals is provided in the following sections.

7.9.1 General purpose parallel I/O

Some device pins that are not dedicated to a specific peripheral function have been designed to be general purpose inputs, outputs, or input/outputs. Also, some pins may be configured either as a specific peripheral function or a general purpose input, output, or input/output. A total of 51 pins can potentially be used as general purpose input/outputs, 24 as general purpose outputs, and 22 as general purpose inputs.

GPIO pins may be dynamically configured as inputs or outputs. Separate registers allow setting or clearing any number of GPIO and GPO outputs controlled by that register simultaneously. The value of the output register for standard GPIOs and GPO pins may be read back, as well as the current actual state of the port pins.

In addition to GPIO pins on port 0, port 1, and port 2, there are 22 GPI, 24 GPO, and six GPIO pins. When the SDRAM bus is configured for 16 data bits, 13 of the remaining SDRAM data pins may be used as GPIOs.

7.9.1.1 Features

- Bit-level set and clear registers allow a single instruction set or clear of any number of bits in one port.
- A single register selects direction for pins that support both input and output modes.
- Direction control of individual bits.
- For input/output pins, both the programmed output state and the actual pin state can be read.
- There are a total of 12 general purpose inputs, 24 general purpose outputs, and six general purpose input/outputs.
- Additionally, 13 SDRAM data lines may be used as GPIOs if a 16-bit SDRAM interface is used (rather than a 32-bit interface).

7.9.2 Keyboard scanner

The keyboard scanner function can automatically scan a keyboard of up to 64 keys in an 8×8 matrix. In operation, the keyboard scanner's internal state machine will normally be in an idle state, with all KEY_ROWn pins set high, waiting for a change in the column inputs to indicate that one or more keys have been pressed.

When a keypress is detected, the matrix is scanned by setting one output pin high at a time and reading the column inputs. After de-bouncing, the keypad state is stored and an interrupt is generated. The keypad is then continuously scanned waiting for 'extra key pressed' or 'key released'. Any new keypad state is scanned and stored into the matrix registers followed by a new interrupt request to the interrupt controller. It is possible to detect and separate up to 64 multiple keys pressed.

7.9.2.1 Features

- Supports up to 64 keys in 8×8 matrix.
- Programmable de-bounce period.
- A key press can wake up the CPU from Stop mode.

7.9.3 Touch screen controller and 10-bit ADC

The LPC3220/30/40/50 microcontrollers includes Touch Screen Controller (TSC) hardware, which automatically measures and determines the X and Y coordinates where a touch screen is pressed. In addition, the TSC can measure an analog input signal on the AUX_IN pin.

Optionally, the TSC can operate as an Analog-to-Digital Converter (ADC). The ADC supports three channels and uses 10-bit successive approximation to produce results with a resolution of 10 bits in 11 clock cycles.

The analog portion of the ADC has its own power supply to enhance the low noise characteristics of the converter. This voltage is only supplied internally when the core has voltage. However, the ADC block is not affected by any difference in ramp-up time for VDD_AD and VDD_CORE voltage supplies.

7.9.3.1 Features

- Measurement range of 0 V to VDD_AD (nominally 3.3 V).
- Low-noise ADC.
- 10-bit resolution.
- Three input channels.
- Uses 32 kHz RTC clock or peripheral clock.

7.9.4 Real-Time Clock (RTC) and battery RAM

The RTC runs at 32768 Hz using a very low power oscillator. The RTC counts seconds and can generate alarm interrupts that can wake up the device from Stop mode. The RTC clock can also clock the 397x PLL, the Millisecond Timer, the ADC, the Keyboard Scanner and the PWMs. The RTC up-counter value represents a number of seconds elapsed since second 0, which is an application determined time. The RTC counter will reach maximum value after about 136 years. The RTC down-counter is initiated with all ones.

Two 32-bit match registers are readable and writable by the processor. A match will result in an interrupt provided that the interrupt is enabled. The ONSW output pin can also be triggered by a match event and cause an external power supply to turn on all of the operating voltages, as a way to startup after power has been removed.

The RTC block is implemented in a separate voltage domain. The block is supplied via a separate supply pin from a battery or other power source.

The RTC block also contains 32 words (128 bytes) of very low voltage SRAM. This SRAM is able to hold its contents down to the minimum RTC operating voltage.

7.9.4.1 Features

- Measures the passage of time in seconds.
- 32-bit up and down seconds counters.
- Ultra-low power design to support battery powered systems.
- Dedicated 32 kHz oscillator.
- An output pin is included to assist in waking up when the chip has had power removed to all functions except the RTC.
- Two 32-bit match registers with interrupt option.
- 32 words (128 bytes) of very low voltage SRAM.
- The RTC and battery RAM power have an independent power domain and dedicated supply pins, which can be powered from a battery or power supply.

Remark: The LPC3220/30/40/50 will run at voltages down to 0.9 V at frequencies below 14 MHz. However, the ARM core cannot access the RTC registers and battery RAM when the core supply voltage is at 0.9 V and the RTC supply is at 1.2 V.

7.9.5 Enhanced 32-bit timers/external event counters

The LPC3220/30/40/50 includes six 32-bit Timer/Counters. The Timer/Counter is designed to count cycles of the system derived clock or an externally-supplied clock. It can optionally generate interrupts or perform other actions at specified timer values, based on four match registers. The Timer/Counter also includes four capture inputs to trap the timer value when an input signal transitions, optionally generating an interrupt.

7.9.5.1 Features

- A 32-bit Timer/Counter with a programmable 32-bit pre-scaler.
- Counter or Timer operation.
- Up to four 32-bit capture channels per timer, that can take a snapshot of the timer value when an input signal transitions. A capture event may also optionally generate an interrupt.
- Four 32-bit match registers that allow:
 - continuous operation with optional interrupt generation on match
 - stop timer on match with optional interrupt generation
 - reset timer on match with optional interrupt generation
- Up to four external outputs corresponding to match registers, with the following capabilities:

- set LOW on match
- set HIGH on match
- toggle on match
- do nothing on match

7.9.6 High-speed timer

The high-speed timer block is clocked by the main peripheral clock. The clock is first divided down in a 16-bit programmable pre-scale counter which clocks a 32-bit timer/counter.

The high-speed timer includes three match registers that are compared to the timer/counter value. A match can generate an interrupt and cause the timer/counter to either continue to run, stop, or be reset. The high-speed timer also includes two capture registers that can take a snapshot of the timer/counter value when an input signal transitions. A capture event may also generate an interrupt.

7.9.6.1 Features

- 32-bit timer/counter with programmable 16-bit pre-scaler.
- Counter or timer operation.
- Two 32-bit capture registers.
- Three 32-bit match registers that allow:
 - Continuous operation with optional interrupt generation on match.
 - Stop timer on match with optional interrupt generation.
 - Reset timer on match with optional interrupt generation.
- Pause control to stop counting when core is in debug state.

7.9.7 Pulse Width Modulators (PWMs)

The LPC3220/30/40/50 provides two simple PWMs. They are clocked separately by either the main peripheral clock or the 32 kHz RTC clock. Both PWMs have a duty cycle programmable in 255 steps.

7.9.7.1 Features

- Clocked by the main peripheral clock or the 32 kHz RTC clock.
- Programmable 4-bit pre-scaler.
- Duty cycle programmable in 255 steps.
- Output frequency up to 50 kHz when using a 13 MHz peripheral clock.

7.9.8 Motor control pulse width modulator

The Motor Control PWM (MCPWM) provides a set of features for three-phase AC and DC motor control applications in a single peripheral. The MCPWM can also be configured for use in other generalized timing, counting, capture, and compare applications.

7.9.8.1 Features

- 32-bit timer
- 32-bit period register

- 32-bit pulse-width (match) register
- 10-bit dead-time register and an associated 10-bit dead-time counter
- 32-bit capture register
- Two PWM (match) outputs (pins MCOA0/1/2 and MCOB0/1/2) with opposite polarities
- Period interrupt, pulse-width interrupt, and capture interrupt

8. Basic architecture

The LPC3220/30/40/50 is a general purpose ARM926EJ-S 32-bit microprocessor with a 32 kB instruction cache and a 32 kB data cache. The microcontroller offers high performance and very low power consumption. The ARM architecture is based on RISC principles, which results in the instruction set and related decode mechanism being much simpler than equivalent micro programmed CISCs. This simplicity results in a high instruction throughput and impressive real-time interrupt response from a small and cost-effective processor core.

The ARM926EJ-S core employs a 5-stage pipeline so processing and memory system accesses can occur continuously. At any one point in time, several operations are in progress: subsequent instruction fetch, next instruction decode, instruction execution, memory access, and write-back. The combination of architectural enhancements gives the ARM9 about 30 % better performance than an ARM7 running at the same clock rate:

- Approximately 1.3 clocks per instruction for the ARM926 compared to 1.9 clocks per instruction for ARM7TDMI.
- Approximately 1.1 Dhrystone MIPS/MHz for the ARM926 compared to 0.9 Dhrystone MIPS/MHz for ARM7TDMI.

The ARM926EJ-S processor also employs an operational state known as Thumb, which makes it ideally suited to high-volume applications with memory restrictions, or applications where code density is an issue.

The key idea behind Thumb state is the use of a super-reduced instruction set. Essentially, the ARM926EJ-S processor core has two instruction sets:

1. The standard 32-bit ARM set
2. The 16-bit Thumb set

The Thumb set's smaller 16-bit instruction length allows it to approach twice the density of standard ARM code while retaining many of ARM's 32-bit performance advantage over a traditional 16-bit processor using 16-bit registers. This is possible because Thumb code operates using the same 32-bit register set as ARM code. Thumb code size is up to 65 % smaller than ARM code size, and 160 % of the performance of an equivalent ARM processor connected to a 16-bit memory system. Additionally, the ARM926EJ-S core includes enhanced DSP instructions and multiplier, as well as an enhanced 32-bit MAC block.

9. Limiting values

Table 7. Limiting values

In accordance with the Absolute Maximum Rating System (IEC 60134).^[1]

| Symbol | Parameter | Conditions | Notes | Min | Max | Unit |
|------------------------|---|--|-------|------|------|------|
| V _{DD(1V2)} | supply voltage (1.2 V) | | [2] | -0.5 | +1.4 | V |
| V _{DD(EMC)} | external memory controller supply voltage | | [3] | -0.5 | +4.6 | V |
| V _{DDA(3V3)} | analog supply voltage (3.3 V) | | [4] | -0.5 | +4.6 | V |
| V _{DD(IO)} | input/output supply voltage | | [5] | -0.5 | +4.6 | V |
| V _{IA} | analog input voltage | | | -0.5 | +4.6 | V |
| V _I | input voltage | 1.8 V pins | [6] | -0.5 | +2.4 | V |
| | | 3.3 V pins | [6] | -0.5 | +4.6 | V |
| I _{DD} | supply current | per supply pin | | - | 100 | mA |
| I _{SS} | ground current | per ground pin | | - | 100 | mA |
| T _{stg} | storage temperature | | | -65 | +150 | °C |
| P _{tot(pack)} | total power dissipation (per package) | max. junction temp 125 °C max. ambient temp 85 °C | [7] | - | 1.12 | W |
| V _{ESD} | electrostatic discharge voltage | HBM | [8] | - | 2500 | V |
| | | CDM | [9] | - | 1000 | V |

[1] The following applies to [Table 7](#):

- a) This product includes circuitry specifically designed for the protection of its internal devices from the damaging effects of excessive static charge. Nonetheless, it is suggested that conventional precautions be taken to avoid applying greater than the rated maximum.
 - b) Parameters are valid over operating temperature range unless otherwise specified. All voltages are with respect to V_{SS} unless otherwise noted.
- [2] Core, PLL, oscillator, and RTC supplies; applies to pins VDD_CORE, VDD_COREFXD, VDD_OSC, VDD_PLL397, VDD_PLLHCLK, VDD_PLLUSB, VDD_RTC, VDD_RTCCORE, and VDD_RTCOSC.
- [3] I/O pad supply; applies to domains VDD_EMC.
- [4] Applies to VDD_AD pins.
- [5] Applies to pins in the following domains VDD_IOA, VDD_IOB, VDD_IOC, and VDD_IOD.
- [6] Including voltage on outputs in 3-state mode.
- [7] Based on package heat transfer, not device power consumption. Calculated package thermal resistance (Theta_{JA}): 35.766 °C/W (with JEDEC Test Board and 0 m/s airflow, ± 15 % accuracy).
- [8] Human body model: equivalent to discharging a 100 pF capacitor through a 1.5 kΩ series resistor.
- [9] Charge device model per AEC-Q100-011.

10. Static characteristics

Table 8. Static characteristics

$T_{amb} = -40\text{ }^{\circ}\text{C}$ to $+85\text{ }^{\circ}\text{C}$, unless otherwise specified.

| Symbol | Parameter | Conditions | Min | Typ ^[1] | Max | Unit |
|-----------------------|---|--|----------|--------------------|------|------|
| V _{DD(1V2)} | supply voltage (1.2 V) | core supply voltage for full performance; 266 MHz (see Figure 4); VDD_CORE supply domain | [2] 1.31 | 1.35 | 1.39 | V |
| | | core supply voltage for normal performance; 208 MHz (see Figure 4); VDD_CORE supply domain | [2] 1.1 | 1.2 | 1.39 | V |
| | | core supply voltage for reduced power; up to 14 MHz CPU; VDD_CORE supply domain | [2] 0.9 | - | 1.39 | V |
| | | RTC supply voltage; VDD_RTC supply domain | [3] 0.9 | - | 1.39 | V |
| | | PLL and oscillator supply voltage | [4] 1.1 | 1.2 | 1.39 | V |
| V _{DD(EMC)} | external memory controller supply voltage | in 1.8 V range | [5] 1.7 | 1.8 | 1.95 | V |
| | | in 2.5 V range | [6] 2.3 | 2.5 | 2.7 | V |
| | | in 3.3 V range | [7] 2.7 | 3.3 | 3.6 | V |
| V _{DD(IO)} | input/output supply voltage | VDD_IOA, VDD_IOB, and VDD_IOD supply domain in 1.8 V range | 1.7 | 1.8 | 1.95 | V |
| | | in 3.3 V range | 2.7 | 3.3 | 3.6 | V |
| | | VDD_IOC supply domain in 1.8 V range | 1.7 | 1.8 | 1.95 | V |
| | | in 3.3 V range | 2.3 | 3.3 | 3.6 | V |
| V _{DDA(3V3)} | analog supply voltage (3.3 V) | applies to pins in VDD_AD power domain | 2.7 | 3.3 | 3.6 | V |

Table 8. Static characteristics ...continued
T_{amb} = -40 °C to +85 °C, unless otherwise specified.

| Symbol | Parameter | Conditions | Min | Typ ^[1] | Max | Unit |
|---|--------------------------------|---|-----|--------------------|-----|------|
| Power consumption in Run, direct Run, and Stop modes | | | | | | |
| I _{DD(run)} | Run mode supply current | T _{amb} = 25 °C; code while(1){} executed from IRAM; all peripherals enabled | | | | |
| | | I-cache/D-cache, MMU enabled; CPU clock = 208 MHz; VDD_CORE = 1.2 V | - | 150 | - | mA |
| | | I-cache/D-cache, MMU enabled; CPU clock = 266 MHz; VDD_CORE = 1.35 V | - | 218 | - | mA |
| | | I-cache/D-cache, MMU disabled; CPU clock = 208 MHz; VDD_CORE = 1.2 V | - | 78 | - | mA |
| | | I-cache/D-cache, MMU disabled; CPU clock = 266 MHz; VDD_CORE = 1.35 V | - | 111 | - | mA |
| I _{DD(drun)} | direct Run mode supply current | T _{amb} = 25 °C; CPU clock = 13 MHz; code while(1){} executed from IRAM; all peripherals disabled | | | | |
| | | I-cache/D-cache, MMU enabled; VDD_CORE = 1.2 V | - | 7.8 | - | mA |
| | | I-cache/D-cache, MMU enabled; VDD_CORE = 0.9 V | - | 5.6 | - | mA |
| | | I-cache/D-cache, MMU disabled; VDD_CORE = 1.2 V | - | 5 | - | mA |
| | | I-cache/D-cache, MMU disabled; VDD_CORE = 0.9 V | - | 3.5 | - | mA |
| I _{DD(stop)} | Stop mode supply current | T _{amb} = 25 °C; CPU clock stopped internally; all peripherals disabled | | | | |
| | | VDD_CORE = 1.2 V | - | 400 | - | μA |
| | | VDD_CORE = 0.9 V | - | 400 | - | μA |

Table 8. Static characteristics ...continued
T_{amb} = -40 °C to +85 °C, unless otherwise specified.

| Symbol | Parameter | Conditions | Min | Typ ^[1] | Max | Unit |
|----------------------|--------------------|---|-----|--------------------|-----|------|
| I _{DD(RTC)} | RTC supply current | VDD_RTC = VDD_RTCCORE = VDD_RTCOSC = 1.2 V; T _{amb} = 25 °C | - | 13 | - | µA |

Input pins and I/O pins configured as input

| | | | | | | |
|--------------------|--------------------------|---|---------------------------|----|---------------------------|----|
| V _I | input voltage | | ^{[8][10]} 0 | - | V _{DD(IO)} | V |
| V _{IH} | HIGH-level input voltage | 1.8 V inputs | 0.7 × V _{DD(IO)} | - | - | V |
| | | 3.3 V inputs | 0.7 × V _{DD(IO)} | - | - | V |
| V _{IL} | LOW-level input voltage | 1.8 V inputs | - | - | 0.3 × V _{DD(IO)} | V |
| | | 3.3 V inputs | - | - | 0.3 × V _{DD(IO)} | V |
| V _{hys} | hysteresis voltage | 1.8 V inputs | 0.1 × V _{DD(IO)} | - | - | V |
| | | 3.3 V inputs | 0.1 × V _{DD(IO)} | - | - | V |
| I _{IL} | LOW-level input current | V _I = 0 V; no pull-up | - | - | 1 | µA |
| I _{IH} | HIGH-level input current | V _I = V _{DD(IO)} ; no pull-down | ^[8] - | - | 1 | µA |
| I _{latch} | I/O latch-up current | -(1.5V _{DD(IO)}) < V _I < (1.5V _{DD(IO)}) | ^[8] - | - | 100 | mA |
| I _{pu} | pull-up current | 1.8 V inputs with pull-up; V _I = 0 V | 6 | 12 | 22 | µA |
| | | 3.3 V inputs with pull-up; V _I = 0 V | 25 | 50 | 80 | µA |
| I _{pd} | pull-down current | 1.8 V inputs with pull-down; V _I = V _{DD(IO)} | 5 | 12 | 22 | µA |
| | | 3.3 V inputs with pull-down; V _I = V _{DD(IO)} | 25 | 50 | 85 | µA |
| C _i | input capacitance | Excluding bonding pad capacitance | - | - | 3.3 | pF |

Output pins and I/O pins configured as output

| | | | | | | |
|-----------------|---------------------------|---|--|---|---------------------|----|
| V _O | output voltage | | ^{[8][9]} 0 ^{[10][11]} | - | V _{DD(IO)} | V |
| V _{OH} | HIGH-level output voltage | 1.8 V outputs; I _{OH} = -1 mA | ^[12] V _{DD(IO)} - 0.4 | - | - | V |
| | | 3.3 V outputs; I _{OH} = -4 mA | ^[12] V _{DD(IO)} - 0.4 | - | - | V |
| V _{OL} | LOW-level output voltage | 1.8 V outputs; I _{OL} = 4 mA | ^[12] - | - | 0.4 | V |
| | | 3.3 V outputs; I _{OL} = 4 mA | ^[12] - | - | 0.4 | V |
| I _{OH} | HIGH-level output current | V _{DD(IO)} = 1.8 V; V _{OH} = V _{DD(IO)} - 0.4 V | ^{[8][12]} -3.3 | - | - | mA |
| | | V _{DD(IO)} = 3.3 V; V _{OH} = V _{DD(IO)} - 0.4 V | -6.5 | - | - | mA |
| I _{OL} | LOW-level output current | V _{DD(IO)} = 1.8 V; V _{OL} = 0.4 V | ^{[8][12]} 1.5 | - | - | mA |
| | | V _{DD(IO)} = 3.3 V; V _{OL} = 0.4 V | 3 | - | - | mA |
| I _{OZ} | OFF-state output current | V _O = 0 V; V _O = V _{DD(IO)} ; no pull-up/down | ^[8] - | - | 1 | µA |

Table 8. Static characteristics ...continued
T_{amb} = -40 °C to +85 °C, unless otherwise specified.

| Symbol | Parameter | Conditions | Min | Typ ^[1] | Max | Unit | |
|--------------------|---|--|-----------------|----------------------------|----------------------------|------|----|
| I _{OHS} | HIGH-level short-circuit output current | V _{DD(IO)} = 1.8 V; V _{OH} = 0 V | [13] | - | 66 | mA | |
| | | V _{DD(IO)} = 3.3 V; V _{OH} = 0 V | - | - | 183 | mA | |
| I _{OLS} | LOW-level short-circuit output current | V _{DD(IO)} = 1.8 V; V _{OL} = V _{DD(IO)} | [8][13] | - | 34 | mA | |
| | | V _{DD(IO)} = 3.3 V; V _{OL} = V _{DD(IO)} | - | - | 105 | mA | |
| | | V _{DD(IO)} | - | - | - | - | |
| Z _o | output impedance | V _{DD(IO)} = 1.8 V | 40 | - | 60 | Ω | |
| | | V _{DD(IO)} = 3.3 V | 40 | - | 60 | Ω | |
| EMC pins | | | | | | | |
| V _I | input voltage | | [10] | 0 | V _{DD(EMC)} | V | |
| V _{IH} | HIGH-level input voltage | 1.8 V inputs | | 0.7 × V _{DD(EMC)} | - | V | |
| | | 3.3 V inputs | | 0.7 × V _{DD(EMC)} | - | V | |
| V _{IL} | LOW-level input voltage | 1.8 V inputs | | - | 0.3 × V _{DD(EMC)} | V | |
| | | 3.3 V inputs | | - | 0.3 × V _{DD(EMC)} | V | |
| V _{hys} | hysteresis voltage | 1.8 V inputs | | 0.4 | 0.6 | V | |
| | | 3.3 V inputs | | 0.55 | 0.85 | V | |
| I _{IL} | LOW-level input current | V _I = 0 V; no pull-up | | - | 0.3 | μA | |
| I _{IH} | HIGH-level input current | V _I = V _{DD(EMC)} ; no pull-down | | - | 0.3 | μA | |
| I _{latch} | I/O latch-up current | -(1.5V _{DD(EMC)}) < V _I < (1.5V _{DD(EMC)}) | | - | 100 | mA | |
| I _{pu} | pull-up current | 1.8 V inputs with pull-up; V _I = 0 | | 34 | 62 | 107 | μA |
| | | 3.3 V inputs with pull-up; V _I = 0 | | 97 | 169 | 271 | μA |
| I _{pd} | pull-down current | 1.8 V inputs with pull-down; V _I = V _{DD(EMC)} | | 23 | 51 | 93 | μA |
| | | 3.3 V inputs with pull-down; V _I = V _{DD(EMC)} | | 73 | 155 | 266 | μA |
| C _i | input capacitance | Excluding bonding pad capacitance | | - | 2.1 | pF | |
| V _O | output voltage | | [9] [10][11] | 0 | V _{DD(EMC)} | V | |
| V _{OH} | HIGH-level output voltage | 1.8 V outputs; I _{OH} = -1 mA | [12] | V _{DD(EMC)} - 0.3 | - | V | |
| | | 3.3 V outputs; I _{OH} = -4 mA | [12] | V _{DD(EMC)} - 0.3 | - | V | |
| V _{OL} | LOW-level output voltage | 1.8 V outputs; I _{OL} = 4 mA | [12] | - | 0.3 | V | |
| | | 3.3 V outputs; I _{OL} = 4 mA | [12] | - | 0.3 | V | |
| I _{OH} | HIGH-level output current | V _{DD(EMC)} = 1.8 V; V _{OH} = V _{DD(EMC)} - 0.4 V | [12] | -6 | - | mA | |
| | | V _{DD(EMC)} = 3.3 V; V _{OH} = V _{DD(EMC)} - 0.4 V | | -6 | - | mA | |

Table 8. Static characteristics ...continued
 $T_{amb} = -40\text{ }^{\circ}\text{C}$ to $+85\text{ }^{\circ}\text{C}$, unless otherwise specified.

| Symbol | Parameter | Conditions | Min | Typ ^[1] | Max | Unit |
|----------------------------|---|--|---------------------------------|--------------------|---------------------------|------|
| I _{OL} | LOW-level output current | V _{DD(EMC)} = 1.8 V; V _{OL} = 0.4 V | [12] 6 | - | - | mA |
| | | V _{DD(EMC)} = 3.3 V; V _{OL} = 0.4 V | 6 | - | - | mA |
| I _{OZ} | OFF-state output current | V _O = 0 V; V _O = V _{DD(EMC)} ; no pull-up/down | - | - | 0.3 | μA |
| I _{OHS} | HIGH-level short-circuit output current | V _{DD(EMC)} = 1.8 V; V _{OH} = 0 V | [13] - | - | -49 | mA |
| | | V _{DD(EMC)} = 3.3 V; V _{OH} = 0 V | - | - | -81 | mA |
| I _{OLS} | LOW-level short-circuit output current | V _{DD(EMC)} = 1.8 V; V _{OL} = V _{DD(EMC)} | [12] - | - | 49 | mA |
| | | V _{DD(EMC)} = 3.3 V; V _{OL} = V _{DD(EMC)} | - | - | 86 | mA |
| Z _o | output impedance | V _{DD(EMC)} = 1.8 V | 35 | 40 | 58 | Ω |
| | | V _{DD(EMC)} = 3.3 V | 32 | 35 | 45 | Ω |
| I²C pins | | | | | | |
| V _I | input voltage | | [8] [10] 0 | - | 5.5V | V |
| V _{IH} | HIGH-level input voltage | 1.8 V inputs | 0.7 × V _{DD(IO)} | - | - | V |
| | | 3.3 V inputs | 0.7 × V _{DD(IO)} | - | - | V |
| V _{IL} | LOW-level input voltage | 1.8 V inputs | - | - | 0.3 × V _{DD(IO)} | V |
| | | 3.3 V inputs | - | - | 0.3 × V _{DD(IO)} | V |
| I _{IL} | LOW-level input current | V _I = 0 V; no pull-up | - | - | 10 | μA |
| I _{IH} | HIGH-level input current | V _I = V _{DD(IO)} ; no pull-down | [8] - | - | 10 | μA |
| I _{latch} | I/O latch-up current | -(1.5V _{DD(IO)}) < V _I < (1.5V _{DD(IO)}) | [8] - | - | 100 | mA |
| C _i | input capacitance | Excluding bonding pad capacitance | - | - | 1.6 | pF |
| V _{OL} | LOW-level output voltage | 1.8 V outputs; I _{OL} = 4 mA | [12] - | - | 0.4 | V |
| | | 3.3 V outputs; I _{OL} = 4 mA | [12] - | - | 0.4 | V |
| I _{OL} | LOW-level output current | V _{DD(IO)} = 1.8 V; V _{OL} = 0.4 V | [8][12] 3 | - | - | mA |
| | | V _{DD(IO)} = 3.3 V; V _{OL} = 0.4 V | 3 | - | - | mA |
| I _{OZ} | OFF-state output current | V _O = 0 V; V _O = V _{DD(IO)} ; no pull-up/down | [8] - | - | 10 | μA |
| I _{OLS} | LOW-level short-circuit output current | V _{DD(IO)} = 1.8 V; V _{OL} = V _{DD(IO)} | [8][13] - | - | 40 | mA |
| | | V _{DD(IO)} = 3.3 V; V _{OL} = V _{DD(IO)} | - | - | 40 | mA |
| ONSW pin | | | | | | |
| V _O | output voltage | | [8][9] [10][11] 0 | - | V _{DD(1V2)} | V |
| V _{OH} | HIGH-level output voltage | 1.2 V outputs; I _{OH} = -1 mA | [12] V _{DD(1V2)} - 0.4 | - | - | V |

Table 8. Static characteristics ...continued
T_{amb} = -40 °C to +85 °C, unless otherwise specified.

| Symbol | Parameter | Conditions | Min | Typ ^[1] | Max | Unit |
|-------------------------------------|---|---|----------------------------|--------------------|----------------------------|------|
| V _{OL} | LOW-level output voltage | 1.2 V outputs; I _{OL} = 4 mA | [12] - | - | 0.4 | V |
| I _{OH} | HIGH-level output current | V _{OH} = V _{DD(1V2)} - 0.4 V | [8][12] -4 | - | - | mA |
| I _{OL} | LOW-level output current | V _{OL} = 0.4 V | [8][12] 3 | - | - | mA |
| I _{OZ} | OFF-state output current | V _O = 0 V; V _O = V _{DD(1V2)} ; no pull-up/down | [8] - | - | 1.5 | μA |
| I _{OHS} | HIGH-level short-circuit output current | V _{DD(1V2)} = 1.8 V; V _{OH} = 0 V | [13] - | - | -135 | mA |
| I _{OLS} | LOW-level short-circuit output current | V _{OL} = V _{DD(1V2)} | [8][13] - | - | 135 | mA |
| Z _o | output impedance | V _{DD(1V2)} = 1.2 V | 40 | - | 60 | Ω |
| Oscillator input/output pins | | | | | | |
| V _{i(xtal)} | crystal input voltage | on pins RTCX_IN and SYSX_IN | -0.5 | - | +1.3 | V |
| V _{o(xtal)} | crystal output voltage | on pins RTCX_OUT and SYSX_OUT | -0.5 | - | +1.3 | V |
| Reset pin | | | | | | |
| V _I | input voltage | | [8] 0 [10] | - | 1.95 | V |
| V _{IH} | HIGH-level input voltage | 1.2 V inputs | 0.7 × V _{DD(1V2)} | - | - | V |
| V _{IL} | LOW-level input voltage | 1.2 V inputs | - | - | 0.3 × V _{DD(1V2)} | V |
| I _{IL} | LOW-level input current | V _I = 0 V; no pull-up | - | - | 1 | μA |
| I _{IH} | HIGH-level input current | V _I = V _{DD} ; no pull-down | [8] - | - | 1 | μA |
| I _{OZ} | OFF-state output current | V _O = 0 V; V _O = V _{DD} ; no pull-up/down | [8] - | - | 1 | μA |
| I _{latch} | I/O latch-up current | -(1.5V _{DD}) < V _I < (1.5V _{DD}) | [8] - | - | 100 | mA |

[1] Typical ratings are not guaranteed. The values listed are at room temperature (25 °C), nominal supply voltages.

[2] Applies to VDD_CORE pins.

[3] Applies to pins VDD_RTC, VDD_RTCCORE, and VDD_RTCOSC.

[4] Applies to pins VDD_COREFXD, VDD_OSC, VDD_PLL397, VDD_PLLHCLK, and VDD_PLLUSB.

[5] Applies when using 1.8 V Mobile DDR or Mobile SDR SDRAM.

[6] Applies when using 2.5 V DDR memory.

[7] Applies when using 3.3 V SDR SDRAM and SRAM.

[8] Referenced to the applicable V_{DD} for the pin.

[9] Including voltage on outputs in 3-state mode.

[10] The applicable V_{DD} voltage for the pin must be present.

[11] 3-state outputs go into 3-state mode when the applicable V_{DD} voltage for the pin is grounded.

[12] Accounts for 100 mV voltage drop in all supply lines.

[13] Allowed as long as the current limit does not exceed the maximum current allowed by the device.

10.1 Minimum core voltage requirements

Figure 4 shows the minimum core supply voltage that should be applied for a given core frequency on pin VDD_CORE to ensure stable operation of the LPC3220/30/40/50.

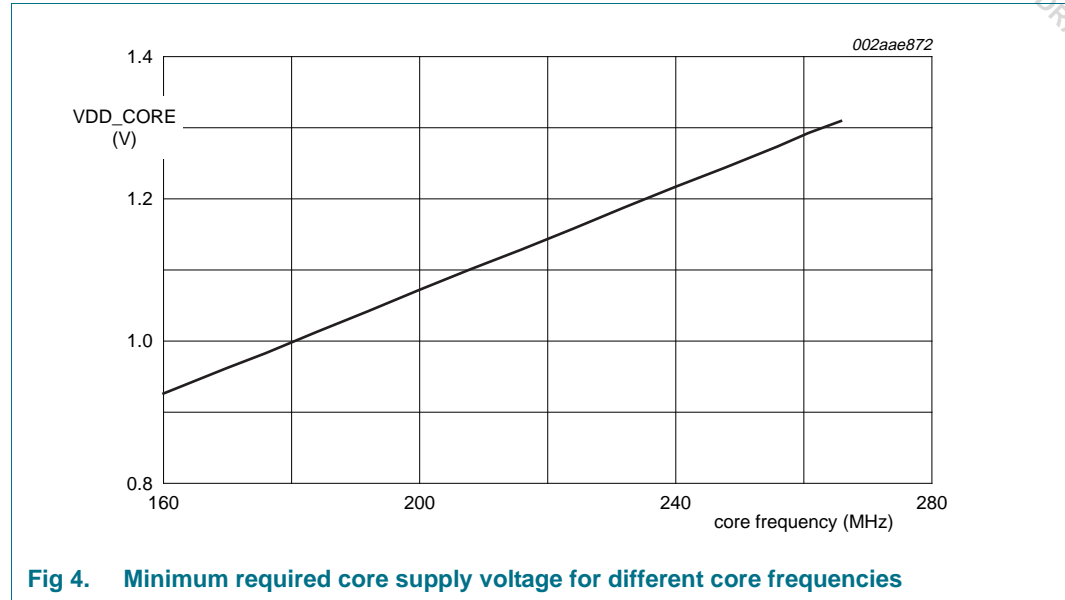

Fig 4. Minimum required core supply voltage for different core frequencies

10.2 Power supply sequencing

The LPC32x0 has no power sequencing requirements, that is, VDD(1V2), VDD(EMC), VDD(IO), and VDDA(3V3) can be switched on or off independent of each other. An internal circuit ensures that the system correctly powers up in the absence of core power. During IO power-up this circuit takes care that the system is powered in a defined mode. The same is valid for core power-down.

10.3 Power consumption per peripheral

Table 9. Power consumption per peripheral

T_{amb} = 25 °C; CPU clock = 208 MHz; I-cache/D-cache, MMU disabled; VDD_CORE = 1.2 V; VDD(IO) = 1.8 V; USB AHB, IRAM, and IROM clocks always on; all peripherals are at their default state at reset. Peripheral clocks are disabled except for peripheral measured.

| Peripheral | I _{DD(run)} / mA |
|---|---------------------------|
| High-speed UART (set to 115 200 Bd (8N1)) | 0.3 |
| I ² C-bus | 0.3 |
| SSP | 0.6 |
| I ² S | 0.5 |
| DMA | 6.3 |
| EMC | 7.3 |
| Multi-level NAND controller | 1.4 |
| Single-level NAND controller | 0.3 |
| LCD | 5.6 |
| Ethernet MAC ^[1] | 2.9 |

[1] All three Ethernet clocks are in enabled in the MAC_CLK_CTRL register (see LPC32x0 User manual).

10.4 Power consumption in Run mode

Power consumption is shown in [Figure 5](#) for WinCE applications running under typical conditions from SDRAM. MMU and I-cache/D-cache are enabled. The VFP is turned on but not used. I²S-interface (channel 1), LCD, SLC NAND controller, I²C1-bus, SD card, touchscreen ADC, and UART3 are turned on. All other peripherals are turned off.

The AHB clock HCLK is identical to the core clock for frequencies up to 133 MHz, which is the maximum allowed HCLK frequency. For higher core frequencies, the HCLK PLL output must be divided by 2 to obtain an HCLK frequency lower than or equal to 133 MHz resulting in correspondingly lower power consumption by the AHB peripherals.

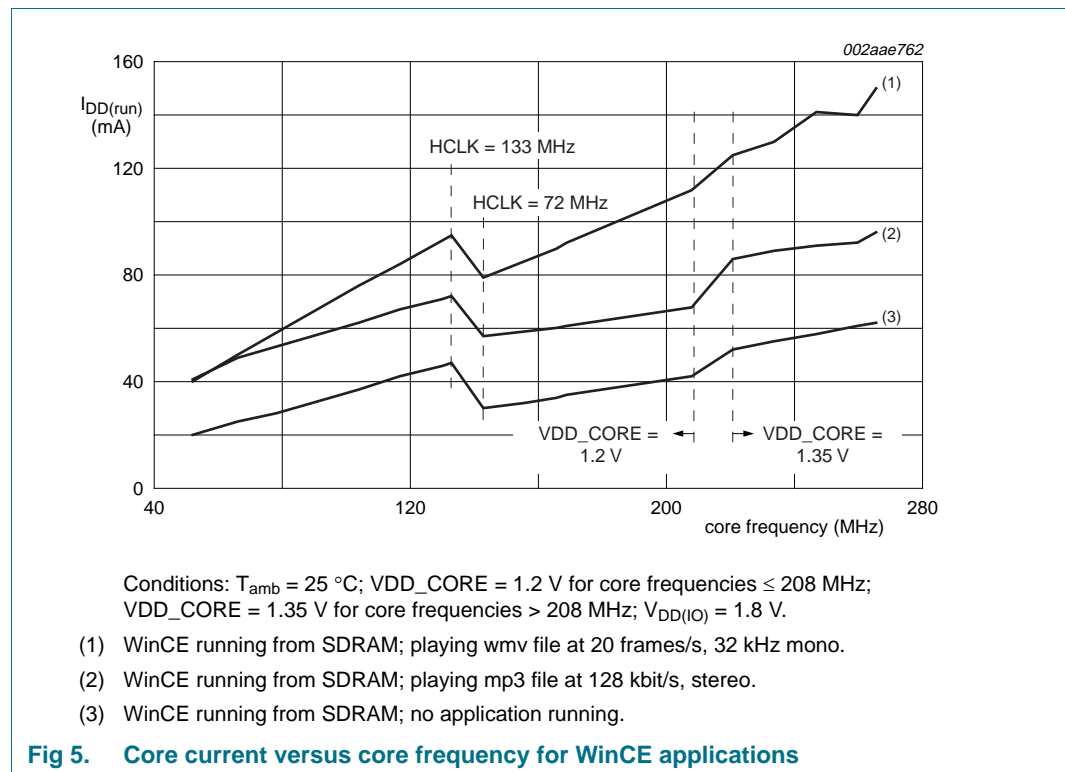

10.5 ADC static characteristics

Table 10. ADC static characteristics

$V_{DDA(3V3)} = 3.3\text{ V}$; $T_{amb} = 25^\circ\text{C}$ unless otherwise specified; ADC clock frequency 4.5 MHz.

| Symbol | Parameter | Conditions | Min | Typ | Max | Unit |
|--------------|-------------------------------------|------------|-----|-----------|----------------|-----------|
| V_{IA} | analog input voltage | | 0 | - | $V_{DDA(3V3)}$ | V |
| C_{ia} | analog input capacitance | | - | - | 1 | pF |
| E_D | differential linearity error | [1][2][3] | - | ± 0.5 | ± 1 | LSB |
| $E_{L(adj)}$ | integral non-linearity | [1][4] | - | ± 0.6 | ± 1 | LSB |
| E_O | offset error | [1][5] | - | ± 1 | ± 3 | LSB |
| E_G | gain error | [1][6] | - | ± 0.3 | ± 0.6 | % |
| E_T | absolute error | [1][7] | - | - | ± 4 | LSB |
| R_{vsi} | voltage source interface resistance | | - | - | 40 | $k\Omega$ |

- [1] Conditions: $V_{SSA} = 0\text{ V}$ (on pin VSS_AD); $V_{DDA(3V3)} = 3.3\text{ V}$ (on pin VDD_AD).
- [2] The ADC is monotonic; there are no missing codes.
- [3] The differential linearity error (E_D) is the difference between the actual step width and the ideal step width. See [Figure 6](#).
- [4] The integral non-linearity ($E_{L(adj)}$) is the peak difference between the center of the steps of the actual and the ideal transfer curve after appropriate adjustment of gain and offset errors. See [Figure 6](#).
- [5] The offset error (E_O) is the absolute difference between the straight line which fits the actual curve and the straight line which fits the ideal curve. See [Figure 6](#).
- [6] The gain error (E_G) is the relative difference in percent between the straight line fitting the actual transfer curve after removing offset error, and the straight line which fits the ideal transfer curve. See [Figure 6](#).
- [7] The absolute error (E_T) is the maximum difference between the center of the steps of the actual transfer curve of the non-calibrated ADC and the ideal transfer curve. See [Figure 6](#).

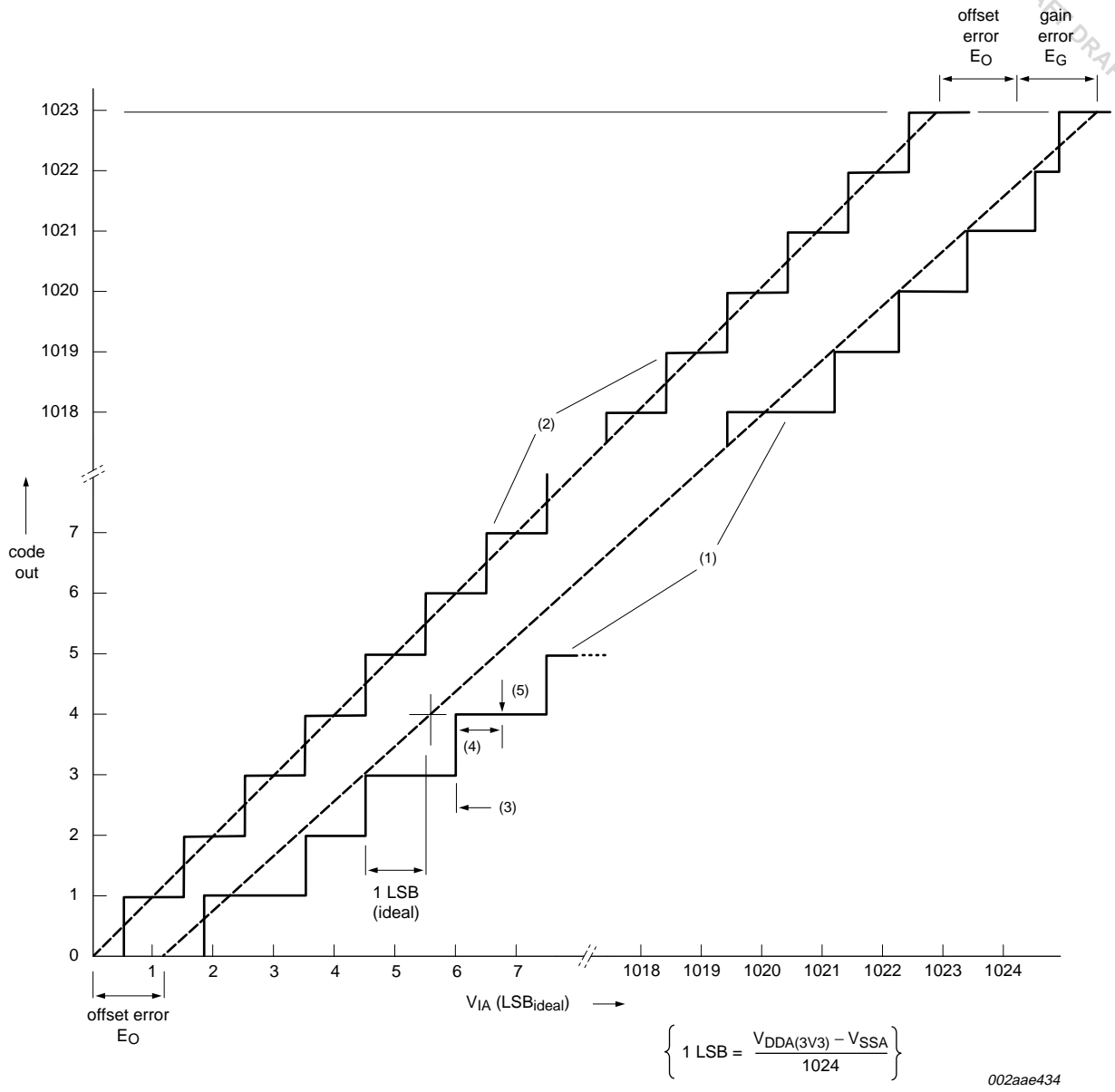

- (1) Example of an actual transfer curve.
- (2) The ideal transfer curve.
- (3) Differential linearity error (E_D).
- (4) Integral non-linearity ($E_{L(adj)}$).
- (5) Center of a step of the actual transfer curve.

Fig 6. ADC characteristics

11. Dynamic characteristics

11.1 Clocking and I/O port pins

Table 11. Dynamic characteristics

$T_{amb} = -40\text{ }^{\circ}\text{C}$ to $+85\text{ }^{\circ}\text{C}$, unless otherwise specified.^[1]

| Symbol | Parameter | Conditions | Min | Typ | Max | Unit |
|---|--|------------|--------|-----|-----|------|
| Reset | | | | | | |
| $t_{w(\overline{\text{RESET}})_{\text{ext}}}$ | external $\overline{\text{RESET}}$ pulse width | | [2] 10 | - | - | ms |
| External clock | | | | | | |
| f_{ext} | external clock frequency | | [3] 1 | 13 | 20 | MHz |
| Port pins | | | | | | |
| t_r | rise time | | - | 5 | - | ns |
| t_f | fall time | | - | 5 | - | ns |

[1] Parameters are valid over operating temperature range unless otherwise specified.

[2] After supply voltages are stable

[3] Supplied by an external crystal.

11.2 Static memory controller

Table 12. Dynamic characteristics: static external memory interface

$C_L = 25\text{ pF}$, $T_{amb} = 20\text{ }^{\circ}\text{C}$, $V_{DD(EMC)} = 1.8\text{ V}$, 2.5 V , or 3.3 V .

| Symbol | Parameter | Notes | Min | Typ | Max | Unit |
|--|--|--------|-----|---|-----|------|
| Common to read and write cycles | | | | | | |
| T_{CLCL} | clock cycle time | [1] | 7.5 | 9.6 | - | ns |
| t_{CSLAV} | $\overline{\text{CS}}$ LOW to address valid time | | - | 0 | - | ns |
| Read cycle parameters | | | | | | |
| t_{OELAV} | $\overline{\text{OE}}$ LOW to address valid time | [2] | - | $0 - \text{WAITOEN} \times T_{\text{CLCL}}$ | - | ns |
| t_{BLSLAV} | $\overline{\text{BLS}}$ LOW to address valid time | [2] | - | $0 - \text{WAITOEN} \times T_{\text{CLCL}}$ | - | ns |
| t_{CSLOEL} | $\overline{\text{CS}}$ LOW to $\overline{\text{OE}}$ LOW time | | - | $0 + \text{WAITOEN} \times T_{\text{CLCL}}$ | - | ns |
| t_{CSLBSL} | $\overline{\text{CS}}$ LOW to $\overline{\text{BLS}}$ LOW time | [2] | - | $0 + \text{WAITOEN} \times T_{\text{CLCL}}$ | - | ns |
| t_{OEOEH} | $\overline{\text{OE}}$ LOW to $\overline{\text{OE}}$ HIGH time | [2][3] | - | $(\text{WAITRD} - \text{WAITOEN} + 1) \times T_{\text{CLCL}}$ | - | ns |
| t_{BLSLBSH} | $\overline{\text{BLS}}$ LOW to $\overline{\text{BLS}}$ HIGH time | [2][3] | - | $(\text{WAITRD} - \text{WAITOEN} + 1) \times T_{\text{CLCL}}$ | - | ns |
| $t_{\text{su(DQ)}}$ | data input/output set-up time | [6] | - | 8.4 | - | ns |
| $t_{\text{h(DQ)}}$ | data input/output hold time | [6] | - | 0 | - | ns |
| t_{CSHOEH} | $\overline{\text{CS}}$ HIGH to $\overline{\text{OE}}$ HIGH time | | - | 0 | - | ns |
| t_{CSHBSH} | $\overline{\text{CS}}$ HIGH to $\overline{\text{BLS}}$ HIGH time | | - | 0 | - | ns |
| t_{OEHANV} | $\overline{\text{OE}}$ HIGH to address invalid time | | - | $1 \times T_{\text{CLCL}}$ | - | ns |
| t_{BLSHANV} | $\overline{\text{BLS}}$ HIGH to address invalid time | | - | $1 \times T_{\text{CLCL}}$ | - | ns |
| Write cycle parameters | | | | | | |
| t_{CSLDV} | $\overline{\text{CS}}$ LOW to data valid time | | - | 0 | - | ns |
| t_{CSLWEL} | $\overline{\text{CS}}$ LOW to $\overline{\text{WE}}$ LOW time | [4] | - | $(\text{WAITWEN} + 1) \times T_{\text{CLCL}}$ | - | ns |
| t_{CSLBSL} | $\overline{\text{CS}}$ LOW to $\overline{\text{BLS}}$ LOW time | [4] | - | $(\text{WAITWEN} + 1) \times T_{\text{CLCL}}$ | - | ns |
| t_{WELDV} | $\overline{\text{WE}}$ LOW to data valid time | [4] | - | $0 - (\text{WAITWEN} + 1) \times T_{\text{CLCL}}$ | - | ns |

Table 12. Dynamic characteristics: static external memory interface ...continued

$C_L = 25 \text{ pF}$, $T_{amb} = 20 \text{ }^\circ\text{C}$, $V_{DD(EMC)} = 1.8 \text{ V}, 2.5 \text{ V}, \text{ or } 3.3 \text{ V}$.

| Symbol | Parameter | Notes | Min | Typ | Max | Unit |
|----------------|--|--------|-----|--|-----|------|
| t_{WELWEH} | \overline{WE} LOW to \overline{WE} HIGH time | [4][5] | - | $(\text{WAITWR} - \text{WAITWEN} + 1) \times T_{CLCL}$ | - | ns |
| $t_{BLSLBSLH}$ | \overline{BLS} LOW to \overline{BLS} HIGH time | [4][5] | - | $(\text{WAITWR} - \text{WAITWEN} + 1) \times T_{CLCL}$ | - | ns |
| t_{WEHANV} | \overline{WE} HIGH to address invalid time | - | - | $1 \times T_{CLCL}$ | - | ns |
| t_{WEHDNV} | \overline{WE} HIGH to data invalid time | - | - | $1 \times T_{CLCL}$ | - | ns |
| $t_{BLSHANV}$ | \overline{BLS} HIGH to address invalid time | - | - | $1 \times T_{CLCL}$ | - | ns |
| $t_{BLSHDNV}$ | \overline{BLS} HIGH to data invalid time | - | - | $1 \times T_{CLCL}$ | - | ns |

- [1] $T_{CLCL} = 1/\text{HCLK}$
- [2] Refer to the *LPC32x0 user manual* EMCStaticWaitOen0-3 register for the programming of WAITOEN value.
- [3] Refer to the *LPC32x0 user manual* EMCStaticWaitRd0-3 register for the programming of WAITRD value.
- [4] Refer to the *LPC32x0 user manual* EMCStaticWaitWen0-3 register for the programming of WAITWEN value.
- [5] Refer to the *LPC32x0 user manual* EMCStaticWaitWr0-3 register for the programming of WAITWR value.
- [6] Earliest of \overline{CS} HIGH, \overline{OE} HIGH, address change to data invalid.

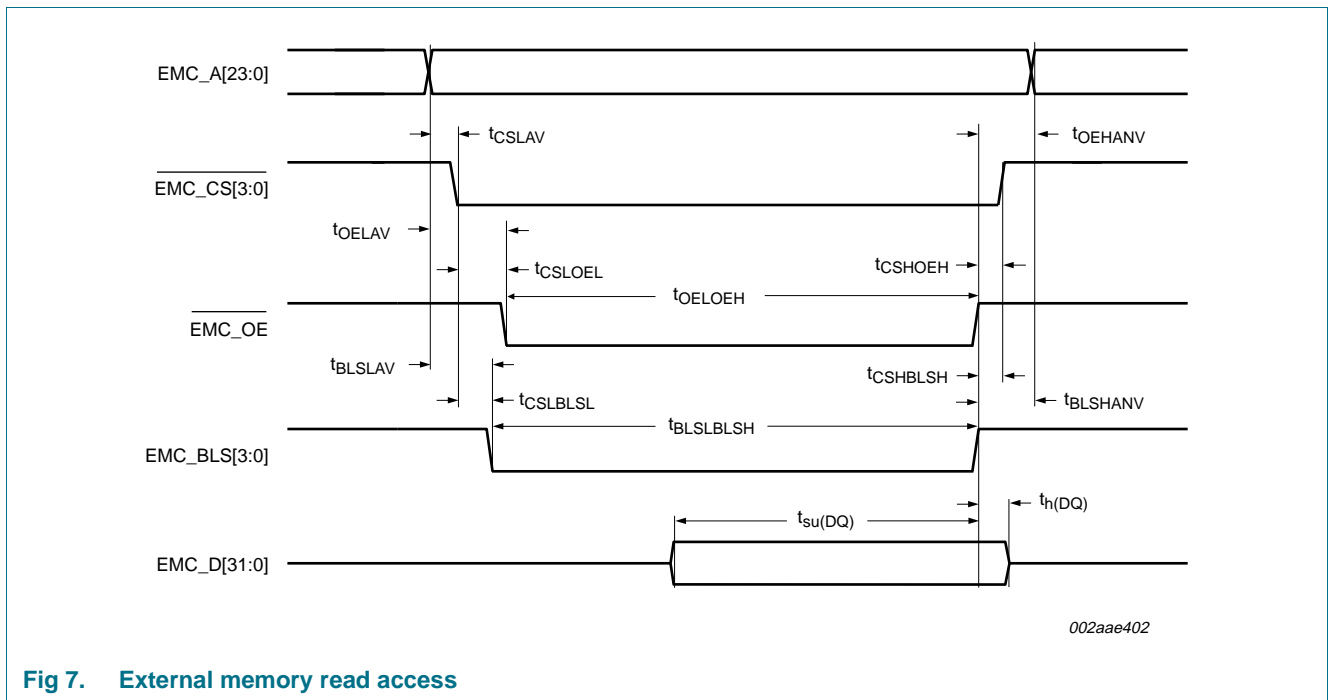

Fig 7. External memory read access

11.3 SDR SDRAM Controller

Table 13. EMC SDR SDRAM memory interface dynamic characteristics

$C_L = 25\text{ pF}$, $T_{amb} = -40\text{ °C to }+85\text{ °C}$, unless otherwise specified.^{[1][3]}

| Symbol | Parameter | Min | Typical ^[2] | Max | Unit |
|----------------|---------------------------------|-------------------|--------------------------------|------------|------|
| f_{oper} | operating frequency | ^[4] | 104 | 133 | MHz |
| t_{CK} | clock cycle time | 7.5 | 9.6 | - | ns |
| t_{CL} | CK LOW-level width | - | 4.8 | - | ns |
| t_{CH} | CK HIGH-level width | - | 4.8 | - | ns |
| $t_{d(V)ctrl}$ | control valid delay time | ^{[5][6]} | $(CMD_DLY \times 0.25) + 2.7$ | - | ns |
| $t_{h(ctrl)}$ | control hold time | ^{[5][6]} | $(CMD_DLY \times 0.25) + 1.2$ | - | ns |
| $t_{d(AV)}$ | address valid delay time | ^[6] | $(CMD_DLY \times 0.25) + 3.2$ | - | ns |
| $t_{h(A)}$ | address hold time | ^[6] | $(CMD_DLY \times 0.25) + 1.2$ | - | ns |
| $t_{d(QV)}$ | data output valid delay time | ^[6] | $(CMD_DLY \times 0.25) + 3.5$ | - | ns |
| $t_{h(Q)}$ | data output hold time | ^[6] | $(CMD_DLY \times 0.25) + 1.2$ | - | ns |
| $t_{su(D)}$ | data input set-up time | - | 0.6 | - | ns |
| $t_{h(D)}$ | data input hold time | - | 0.9 | - | ns |
| t_{QZ} | data output high-impedance time | - | - | $< t_{CK}$ | ns |

- [1] Parameters are valid over operating temperature range unless otherwise specified.
- [2] Typical values valid for EMC pads set to fast slew rate: $VDD_EMC = 1.8\text{ V}$, $VDD_CORE = 1.2\text{ V}$ or slower slew rate: $VDD_EMC = 3.3\text{ V}$, $VDD_CORE = 1.2\text{ V}$ (see SDRAMCLK_CTRL register in the *LPC32x0 User manual*).
- [3] All min or max values valid for EMC pads set to fast slew rate: $VDD_EMC = 1.8\text{ V}$, $VDD_CORE = 1.2\text{ V}$ or slower slew rate: $VDD_EMC = 3.3\text{ V}$, $VDD_CORE = 1.2\text{ V}$.
- [4] $f_{oper} = 1/t_{CK}$.
- [5] Applies to signals: EMC_DQM[3:0], EMC_DYCSm, EMC_RAS, EMC_CAS, EMC_WR, EMC_CKEm.
- [6] CMD_DLY = COMMAND_DELAY bitfield in SDRAMCLK_CTRL[18:14] register, see *External memory controller (EMC) chapter in LPC32x0 User manual*.

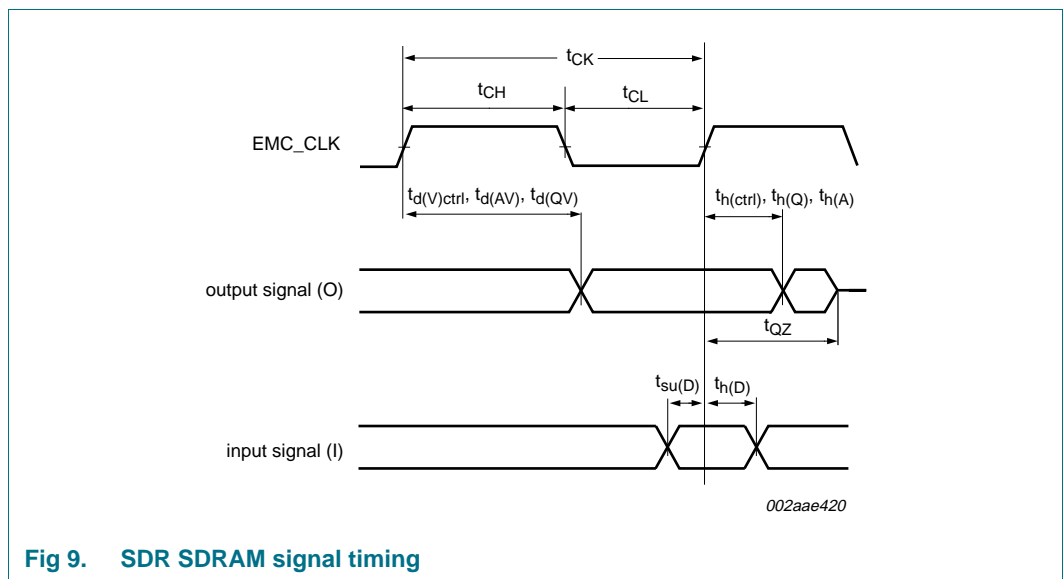

Fig 9. SDR SDRAM signal timing

11.4 DDR SDRAM controller

Table 14. EMC DDR SDRAM memory interface dynamic characteristics^[1]

$C_L = 25\text{ pF}$, $T_{amb} = 25\text{ }^\circ\text{C}$, unless otherwise specified.

| Symbol | Parameter | Conditions | Min | Typical | Max | Unit |
|----------------|---|----------------------------------|--------|--------------------------------|----------------------|-------------------------|
| f_{oper} | operating frequency | | - | 104 | 133 | MHz |
| t_{CK} | clock cycle time | | 7.5 | 9.6 | - | ns |
| t_{CL} | CK LOW-level width | | - | $0.5 \times t_{CK}$ | - | ns |
| t_{CH} | CK HIGH-level width | | - | $0.5 \times t_{CK}$ | - | ns |
| $t_{d(V)ctrl}$ | control valid delay time | | [2][3] | $(CMD_DLY \times 0.25) + 1.5$ | - | ns |
| $t_{h(ctrl)}$ | control hold time | | [2][3] | $(CMD_DLY \times 0.25) - 1.5$ | - | ns |
| $t_{d(AV)}$ | address valid delay time | | [2] | $(CMD_DLY \times 0.25) + 1.5$ | - | ns |
| $t_{h(A)}$ | address hold time | | [2] | $(CMD_DLY \times 0.25) - 1.5$ | - | ns |
| $t_{su(Q)}$ | data output set-up time | EMC_D and EMC_DQM to EMC_DQS out | [5] | $0.08 \times t_{CK}$ | $0.15 \times t_{CK}$ | $0.25 \times t_{CK}$ ns |
| $t_{h(Q)}$ | data output hold time | EMC_D and EMC_DQM to EMC_DQS out | [5] | $0.25 \times t_{CK}$ | $0.35 \times t_{CK}$ | $0.42 \times t_{CK}$ ns |
| t_{DQSH} | DQS HIGH time | for WRITE command | - | $0.5 \times t_{CK}$ | - | ns |
| t_{DQSL} | DQS LOW time | for WRITE command | - | $0.5 \times t_{CK}$ | - | ns |
| t_{DQSS} | WRITE command to first DQS latching transition time | for DQS out | - | $t_{CK} + 0.7$ | - | ns |
| t_{DSS} | DQS falling edge to CK set-up time | for DQS in | - | $0.5 \times t_{CK}$ | - | ns |
| t_{DSH} | DQS falling edge hold time from CK | for DQS in | - | $0.5 \times t_{CK}$ | - | ns |
| $t_{d(DQS)}$ | DQS delay time | for DQS in | [4] | DQS_DELAY | - | ns |
| $t_{su(D)}$ | data input set-up time | | - | 0.3 | - | ns |
| $t_{h(D)}$ | data input hold time | | - | 0.5 | - | ns |

- [1] All values valid for EMC pads set to fast slew rate at 1.8 V unless otherwise specified (see SDRAMCLK_CTRL register in the *LPC32x0 User manual*).
- [2] CMD_DLY = COMMAND_DELAY bitfield in SDRAMCLK_CTRL[18:14] register, see *External memory controller (EMC) chapter in LPC32x0 User manual*.
- [3] Applies to signals EMC_DQM[1:0], $\overline{\text{EMC_DYCSm}}$, $\overline{\text{EMC_RAS}}$, $\overline{\text{EMC_CAS}}$, $\overline{\text{EMC_WR}}$, EMC_CKEm.
- [4] DQS_DELAY, see *LPC32x0 user manual, External Memory Controller Chapter, Section 8 DDR DQS delay calibration* for details on configuring this value.
- [5] Test conditions for measurements: $T_{amb} = -40\text{ }^\circ\text{C}$ to $+85\text{ }^\circ\text{C}$; operating frequency range $f_{oper} = 52\text{ MHz}$ to 133 MHz ; EMC_DQMm and EMC_D[31:0] driving 2 inches of $50\ \Omega$ characteristic impedance trace with 10 pf capacitive load; no external source series termination resistors used. EMC pads set to fast slew rate at 1.8 V or 2.5 V (see SDRAMCLK_CTRL register in the *LPC32x0 User manual*).

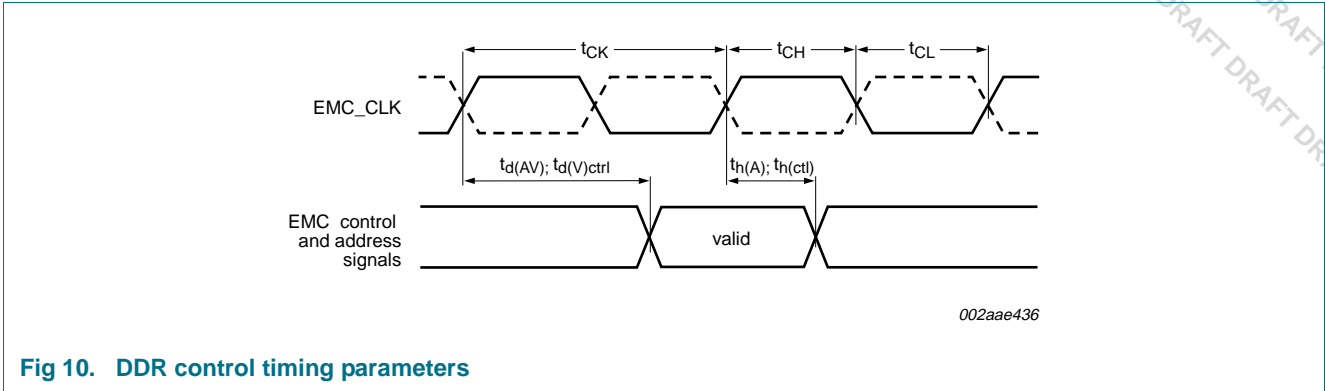

Fig 10. DDR control timing parameters

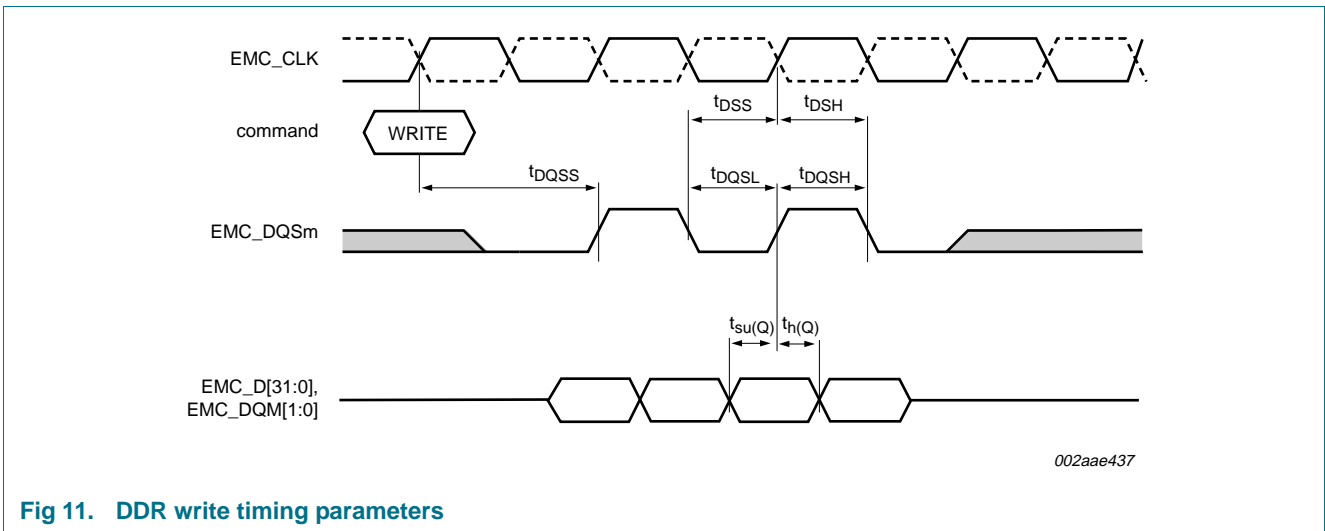
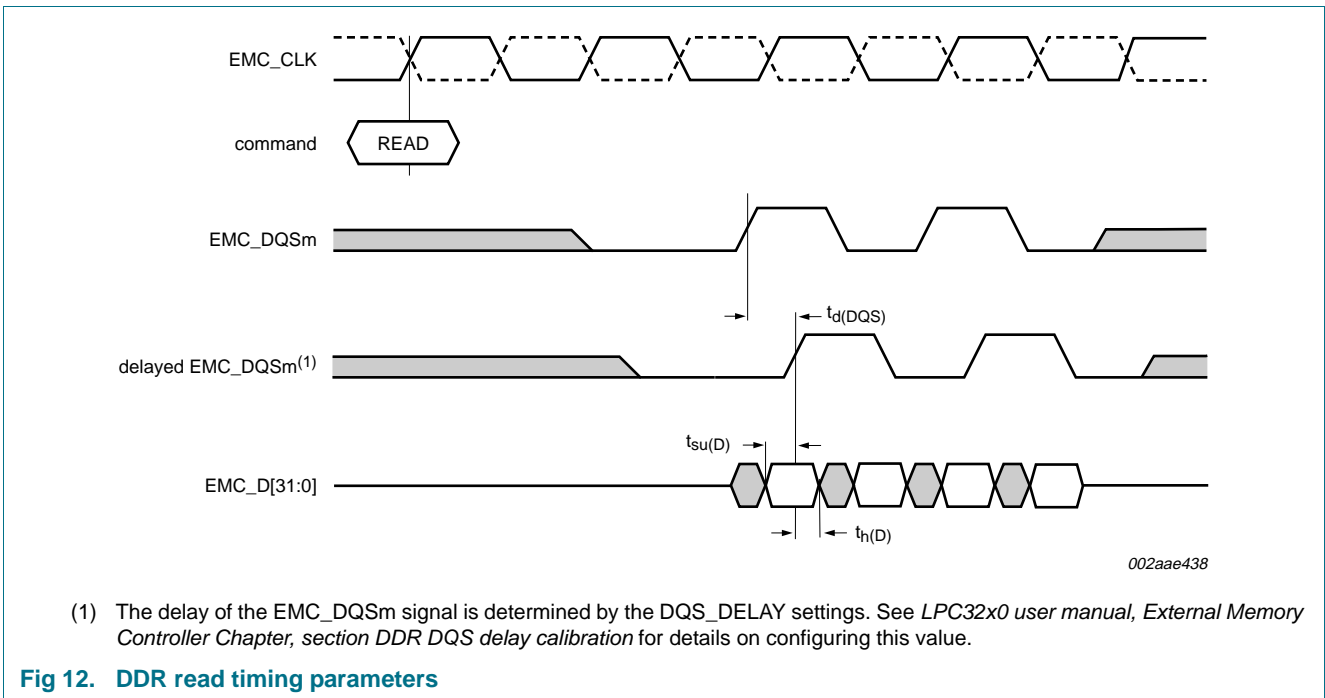

Fig 11. DDR write timing parameters



(1) The delay of the EMC_DQSm signal is determined by the DQS_DELAY settings. See *LPC32x0 user manual, External Memory Controller Chapter, section DDR DQS delay calibration* for details on configuring this value.

Fig 12. DDR read timing parameters

11.5 USB controller

Table 15. Dynamic characteristics USB digital I/O pins

$V_{DD(I/O)} = 3.3\text{ V}$; $T_{amb} = -40\text{ }^{\circ}\text{C}$ to $+85\text{ }^{\circ}\text{C}$, unless otherwise specified.^[1]

| Symbol | Parameter | Conditions | Min | Typ | Max | Unit |
|-----------|---------------------------|---------------------------------|-----|-----|-----|------|
| t_{TIO} | bus turnaround time (I/O) | OE_N/INT_N to DAT/VP and SE0/VM | - | 7 | - | ns |
| t_{TOI} | bus turnaround time (O/I) | OE_N/INT_N to DAT/VP and SE0/VM | - | 0 | - | ns |

[1] Parameters are valid over operating temperature range unless otherwise specified.

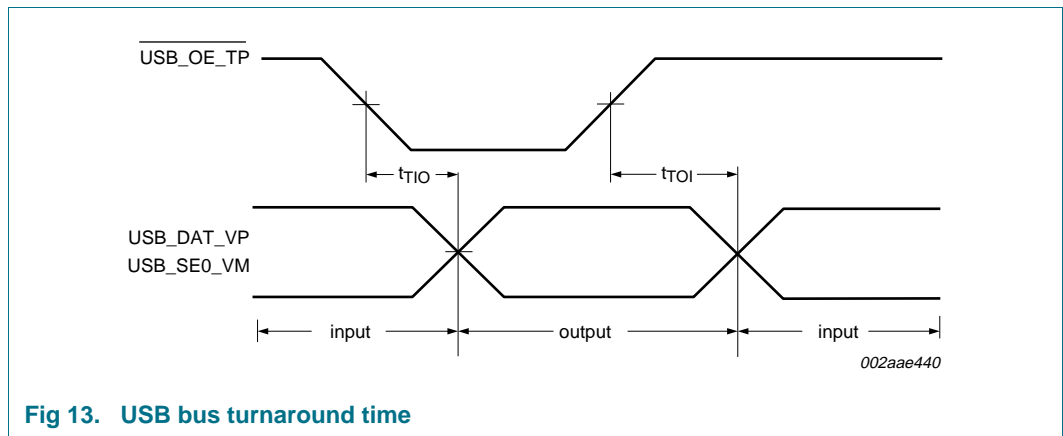

Fig 13. USB bus turnaround time

11.6 Secure Digital (SD) card interface

Table 16. Dynamic characteristics: SD card pin interface

$T_{amb} = -40\text{ }^{\circ}\text{C}$ to $+85\text{ }^{\circ}\text{C}$ for industrial applications; $V_{DD(I/O)}$ over specified ranges.^[1]

| Symbol | Parameter | Conditions | Min | Typ ^[2] | Max | Unit |
|----------------------|------------------------------|---------------------------------------|-----|--------------------|-----|------|
| $T_{cy(\text{clk})}$ | clock cycle time | on pin MS_SCLK; Data transfer mode | - | - | 25 | MHz |
| | | on pin MS_SCLK; Identification mode | - | - | 400 | kHz |
| $t_{su(D)}$ | data input set-up time | on pins MS_BS, MS_DIO[3:0] as inputs | - | 2.7 | - | ns |
| $t_{h(D)}$ | data input hold time | on pins MS_BS, MS_DIO[3:0] as inputs | - | 0 | - | ns |
| $t_{d(QV)}$ | data output valid delay time | on pins MS_BS, MS_DIO[3:0] as outputs | - | 9.7 | - | ns |
| $t_{h(Q)}$ | data output hold time | on pins MS_BS, MS_DIO[3:0] as outputs | - | 7.7 | - | ns |

[1] Parameters are valid over operating temperature range unless otherwise specified.

[2] Typical ratings are not guaranteed. The values listed are at room temperature (25 °C), nominal supply voltages.

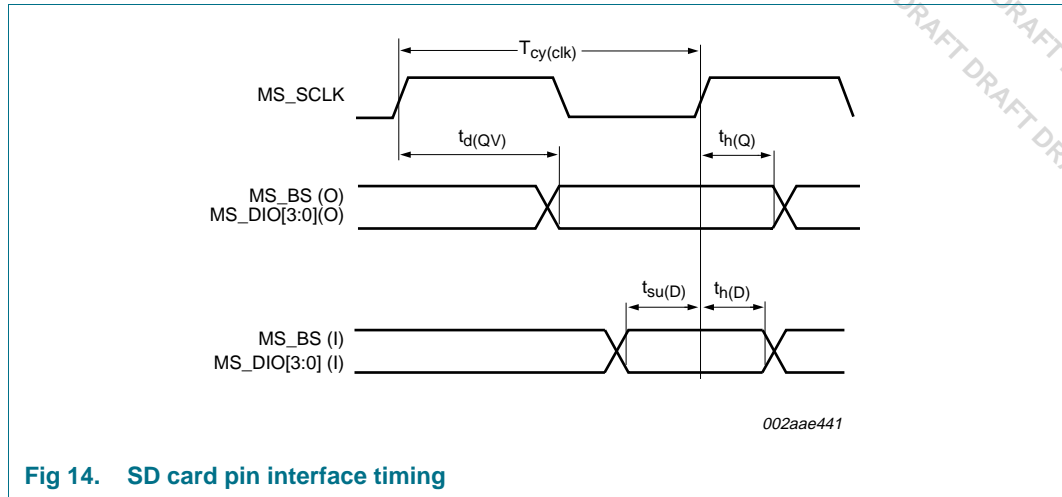

Fig 14. SD card pin interface timing

11.7 MLC NAND flash memory controller

Table 17. Dynamic characteristics of the MLC NAND flash memory controller

$T_{amb} = -40\text{ }^{\circ}\text{C}$ to $+85\text{ }^{\circ}\text{C}$.

| Symbol | Parameter | Min | Typ | Max | Unit |
|--------------|--|-----------|-----|---|------|
| t_{CELREL} | \overline{CE} LOW to \overline{RE} LOW time | [1][2] | - | $T_{HCLK} \times CEA_D$ | ns |
| t_{RC} | \overline{RE} cycle time | [1][5][6] | - | $T_{HCLK} \times (R_L + 1) + T_{HCLK} \times (R_H - R_L)$ | ns |
| t_{REH} | \overline{RE} HIGH hold time | [1][5][6] | - | $T_{HCLK} \times (R_H - R_L)$ | ns |
| t_{RHZ} | \overline{RE} HIGH to output high-impedance time | [1][5][7] | - | $T_{HCLK} \times (R_H - R_L) + T_{HCLK} \times R_{HZ}$ | ns |
| t_{RP} | \overline{RE} pulse width | [1][5] | - | $T_{HCLK} \times (R_L + 1)$ | ns |
| t_{REHRBL} | \overline{RE} HIGH to R/\overline{B} LOW time | [1][8] | - | $T_{HCLK} \times B_D$ | ns |
| t_{WB} | \overline{WE} HIGH to R/\overline{B} LOW time | [1][8] | - | $T_{HCLK} \times B_D$ | ns |
| t_{WC} | \overline{WE} cycle time | [1][3][4] | - | $T_{HCLK} \times (W_L + 1) + T_{HCLK} \times (W_H - W_L)$ | ns |
| t_{WH} | \overline{WE} HIGH hold time | [1][3][4] | - | $T_{HCLK} \times (W_H - W_L)$ | ns |
| t_{WP} | \overline{WE} pulse width | [1][3] | - | $T_{HCLK} \times (W_L + 1)$ | ns |

- [1] $T_{HCLK} = 1/HCLK$
- [2] CEA_D = bitfield TCEA_DELAY[1:0] in register MLC_TIME_REG[25:24]
- [3] W_L = bitfield WR_LOW[3:0] in register MLC_TIME_REG[3:0]
- [4] W_H = bitfield WR_HIGH[3:0] in register MLC_TIME_REG[7:4]
- [5] R_L = bitfield RD_LOW[3:0] in register MLC_TIME_REG[11:8]
- [6] R_H = bitfield RD_HIGH [3:0] in register MLC_TIME_REG[15:12]
- [7] R_{HZ} = bitfield NAND_TA[2:0] in register MLC_TIME_REG[18:16]
- [8] B_D = bitfield BUSY_DELAY[4:0] in register MLC_TIME_REG[23:19]

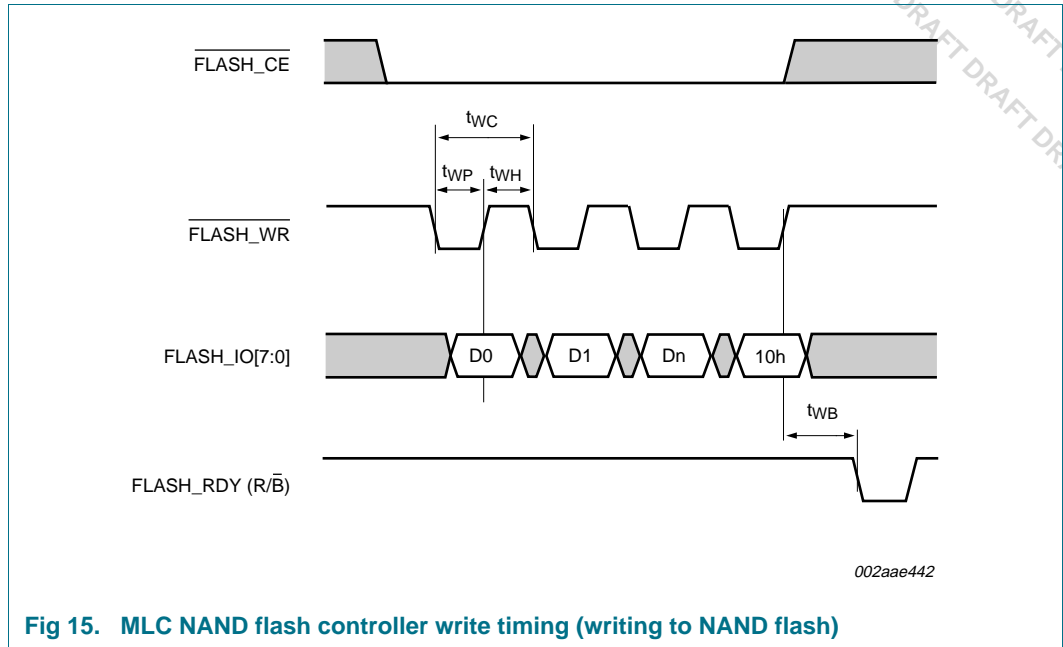

Fig 15. MLC NAND flash controller write timing (writing to NAND flash)

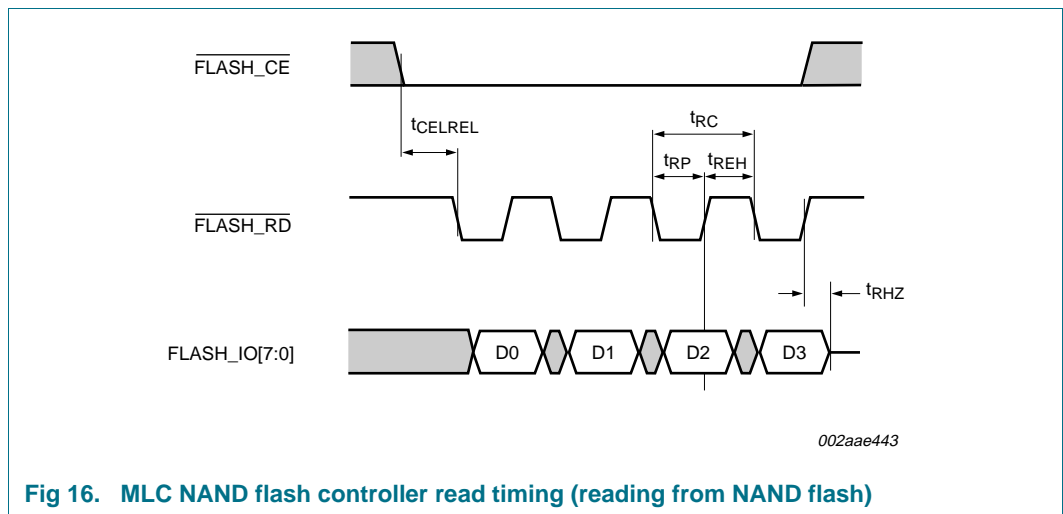

Fig 16. MLC NAND flash controller read timing (reading from NAND flash)

11.8 SLC NAND flash memory controller

Table 18. Dynamic characteristics of SLC NAND flash memory controller

$T_{amb} = -40\text{ }^{\circ}\text{C}$ to $+85\text{ }^{\circ}\text{C}$.

| Symbol | Parameter | Conditions | Min | Typ | Max | Unit |
|-----------|----------------------|------------|--------------|-----|------------------------------|------|
| t_{ALS} | ALE set-up time | read | [1][2][4][6] | - | $T_{HCLK} \times (Rsu + Rw)$ | ns |
| | | write | - | - | $T_{HCLK} \times (Wsu + Ww)$ | ns |
| t_{ALH} | ALE hold time | read | [1][7] | - | $T_{HCLK} \times Rh$ | ns |
| | | write | - | - | $T_{HCLK} \times Wh$ | ns |
| t_{AR} | ALE to RE delay time | read | [1][2][6] | - | $T_{HCLK} \times Rsu$ | ns |
| | | write | - | - | $T_{HCLK} \times Wsu$ | ns |

Table 18. Dynamic characteristics of SLC NAND flash memory controller ...continued

$T_{amb} = -40\text{ }^{\circ}\text{C to }+85\text{ }^{\circ}\text{C}$.

| Symbol | Parameter | Conditions | Min | Typ | Max | Unit |
|-------------------|--|---|-----|---|-----|------|
| t _{CEA} | $\overline{\text{CE}}$ access time | read [1][2][4][6][8] | - | $T_{\text{HCLK}} \times (\text{Rsu} + \text{Rw})$ | - | ns |
| | | write | - | $T_{\text{HCLK}} \times (\text{Wsu} + \text{Ww})$ | - | ns |
| t _{CS} | $\overline{\text{CE}}$ set-up time | read [1][2][4][6][8] | - | $T_{\text{HCLK}} \times (\text{Rsu} + \text{Rw})$ | - | ns |
| | | write | - | $T_{\text{HCLK}} \times (\text{Wsu} + \text{Ww})$ | - | ns |
| t _{CH} | $\overline{\text{CE}}$ hold time | read [1][3] | - | $T_{\text{HCLK}} \times \text{Rh}$ | - | ns |
| | | write | - | $T_{\text{HCLK}} \times \text{Wh}$ | - | ns |
| t _{CLS} | CLE set-up time | read [1][2][4][6][8] | - | $T_{\text{HCLK}} \times (\text{Rsu} + \text{Rw})$ | - | ns |
| | | write | - | $T_{\text{HCLK}} \times (\text{Wsu} + \text{Ww})$ | - | ns |
| t _{CLH} | CLE hold time | read [1][3] | - | $T_{\text{HCLK}} \times \text{Rh}$ | - | ns |
| | | write | - | $T_{\text{HCLK}} \times \text{Wh}$ | - | ns |
| t _{CLR} | CLE to $\overline{\text{RE}}$ delay time | read [1][2][6] | - | $T_{\text{HCLK}} \times \text{Rsu}$ | - | ns |
| | | write | - | $T_{\text{HCLK}} \times \text{Wsu}$ | - | ns |
| t _{DH} | data hold time | output from NAND controller; read [1][3][7] | - | $T_{\text{HCLK}} \times \text{Rh}$ | - | ns |
| | | output from NAND controller; write | - | $T_{\text{HCLK}} \times \text{Wh}$ | - | ns |
| t _{DS} | data set-up time | output from NAND controller; read [1][2][4][6][8] | - | $T_{\text{HCLK}} \times (\text{Rsu} + \text{Rw})$ | - | ns |
| | | output from NAND controller; write | - | $T_{\text{HCLK}} \times (\text{Wsu} + \text{Ww})$ | - | ns |
| t _{IR} | output high-impedance to $\overline{\text{RE}}$ LOW time | read [1][2][6] | - | $T_{\text{HCLK}} \times \text{Rsu}$ | - | ns |
| | | write | - | $T_{\text{HCLK}} \times \text{Wsu}$ | - | ns |
| t _{RC} | $\overline{\text{RE}}$ cycle time | read [1][2] | - | $T_{\text{HCLK}} \times (\text{Rsu} + \text{Rw} + \text{Rh})$ | - | ns |
| t _{REA} | $\overline{\text{RE}}$ access time | read [1][4] | - | $T_{\text{HCLK}} \times \text{Rw}$ | - | ns |
| t _{REH} | $\overline{\text{RE}}$ high hold time | read [1][2][3] | - | $T_{\text{HCLK}} \times (\text{Rsu} + \text{Rh})$ | - | ns |
| t _{RHOH} | $\overline{\text{RE}}$ HIGH to output hold time | input hold for flash controller; read | - | 0 | - | - |
| | | input hold for flash controller; write | - | 0 | - | - |
| t _{RHZ} | $\overline{\text{RE}}$ HIGH to output high-impedance time | read [1] | - | $T_{\text{HCLK}} \times \text{Rh}$ | - | ns |
| t _{RP} | $\overline{\text{RE}}$ pulse width | read [1][4] | - | $T_{\text{HCLK}} \times \text{Rw}$ | - | ns |
| t _{RR} | ready to $\overline{\text{RE}}$ LOW time | read [1][2][3] | - | $T_{\text{HCLK}} \times \text{Rsu}$ | - | ns |
| t _{WB} | $\overline{\text{WE}}$ HIGH to $\text{R}/\overline{\text{B}}$ LOW time | write [1][8] | - | $T_{\text{HCLK}} \times \text{Ww}$ | - | ns |
| t _{WC} | $\overline{\text{WE}}$ cycle time | write [1][6][7][8] | - | $T_{\text{HCLK}} \times (\text{Wsu} + \text{Ww} + \text{Wh})$ | - | ns |

Table 18. Dynamic characteristics of SLC NAND flash memory controller ...continued

$T_{amb} = -40\text{ }^{\circ}\text{C to } +85\text{ }^{\circ}\text{C}$.

| Symbol | Parameter | Conditions | Min | Typ | Max | Unit |
|--------------|---|-----------------|-----|------------------------------|-----|------|
| t_{WH} | \overline{WE} HIGH hold time | write [1][6][7] | - | $T_{HCLK} \times (Wsu + Wh)$ | - | ns |
| t_{WHR} | \overline{WE} HIGH to \overline{RE} LOW time | write [1][6][7] | - | $T_{HCLK} \times (Wsu + Wh)$ | - | ns |
| t_{WP} | \overline{WE} pulse width | write [1][8] | - | $T_{HCLK} \times Ww$ | - | ns |
| t_{REHRBL} | \overline{RE} HIGH to R/\overline{B} LOW time | write [1][9] | - | $T_{HCLK} \times Ww$ | - | ns |

- [1] $T_{HCLK} = 1/HCLK$
- [2] Rsu = bitfield R_SETUP[3:0] in register SLC_TAC[3:0] for reads
- [3] Rh = bitfield R_HOLD[3:0] in register SLC_TAC[7:4] for reads
- [4] Rw = bitfield R_WIDTH[3:0] in register SLC_TAC[11:8] for reads
- [5] Rb = bitfield R_RDY[3:0] in register SLC_TAC[15:12] for reads
- [6] Wsu = bitfield W_SETUP[3:0] in register SLC_TAC[19:16] for writes
- [7] Wh = bitfield W_HOLD[3:0] in register SLC_TAC[23:20] for writes
- [8] Ww = bitfield W_WIDTH[3:0] in register SLC_TAC[27:24] for writes
- [9] Wb = bitfield W_RDY[3:0] in register SLC_TAC[31:28] for writes

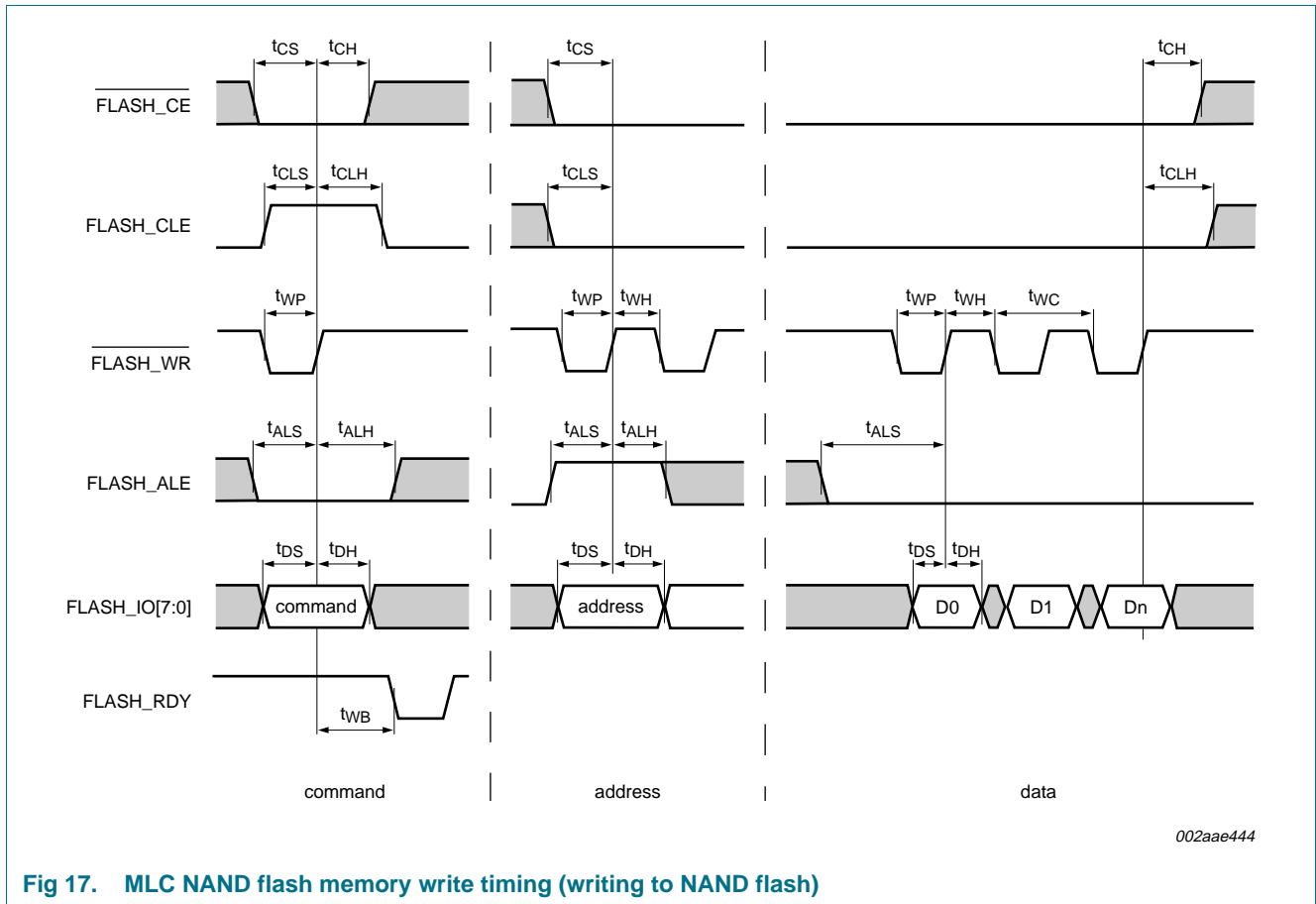

Fig 17. MLC NAND flash memory write timing (writing to NAND flash)

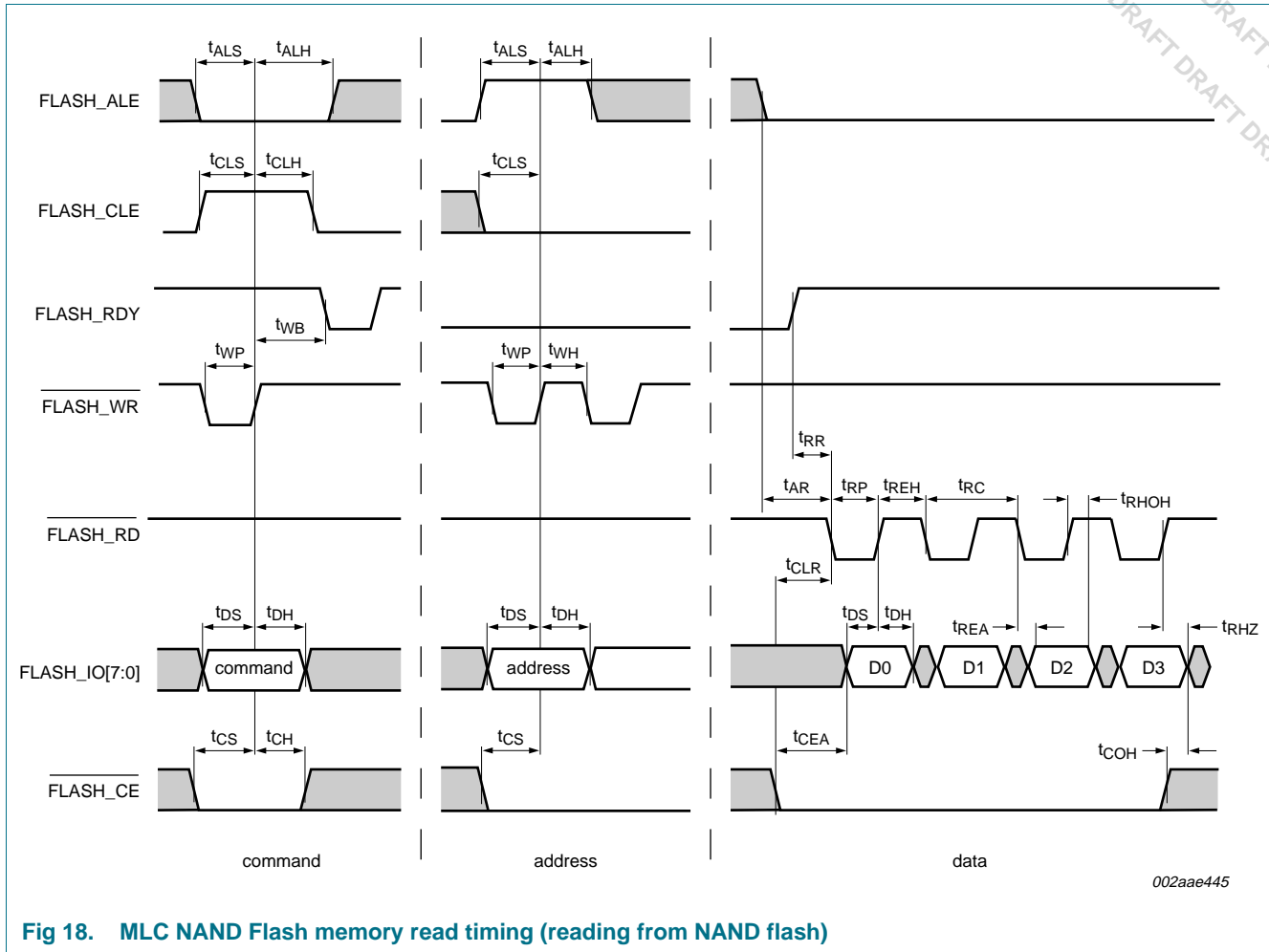

Fig 18. MLC NAND Flash memory read timing (reading from NAND flash)

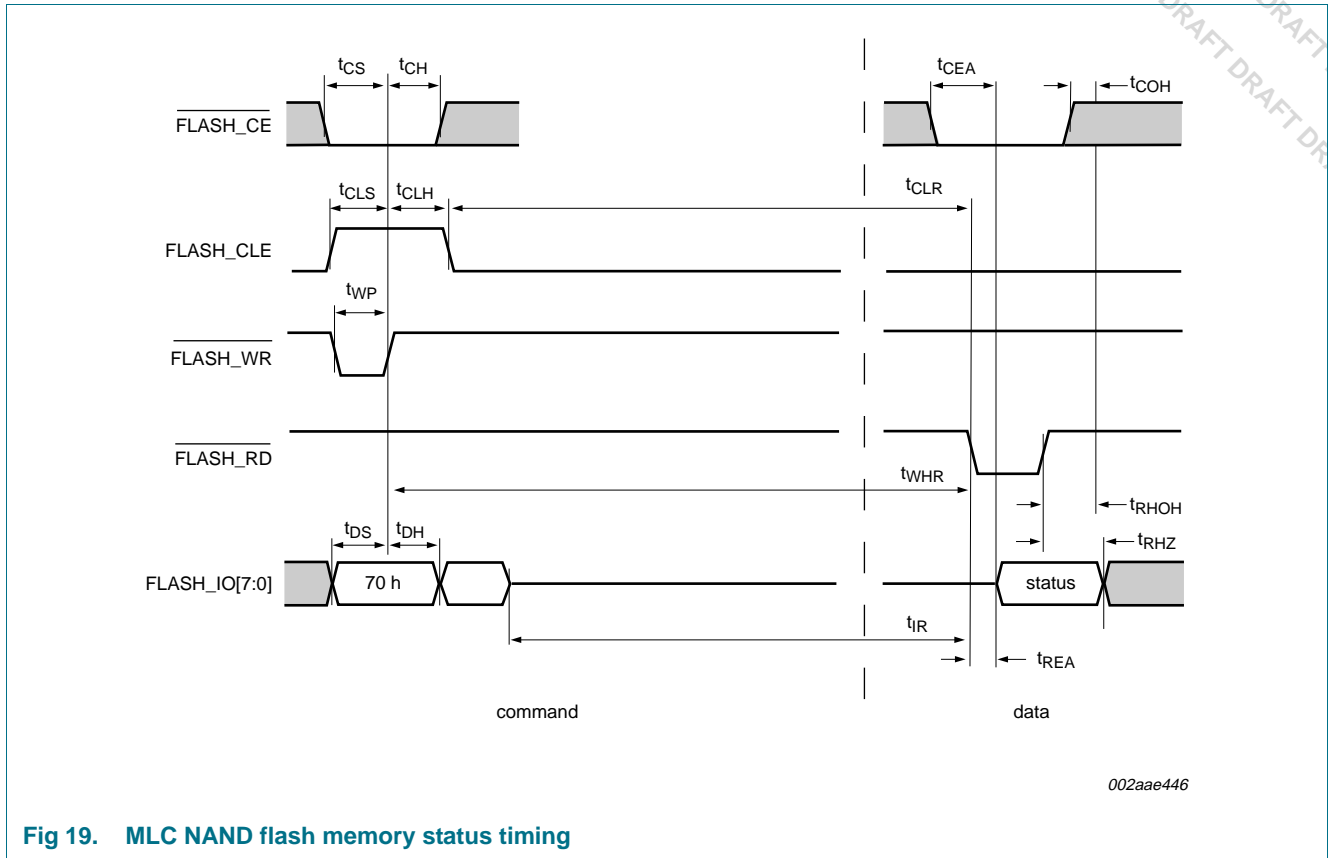

Fig 19. MLC NAND flash memory status timing

11.9 SPI and SSP Controller

11.9.1 SPI

Table 19. Dynamic characteristics of SPI pins on SPI master controller

$T_{amb} = -40\text{ }^{\circ}\text{C to }+85\text{ }^{\circ}\text{C}$.

| Symbol | Parameter | Min | Typ | Max | Unit |
|--------------------------------|--------------------------------------|-------------------------|-----|-----------------------|------|
| Common to SPI1 and SPI2 | | | | | |
| T_{SPICYC} | SPI cycle time | [1] $2 \times T_{HCLK}$ | - | $256 \times T_{HCLK}$ | ns |
| SPI1 | | | | | |
| t_{SPIDSU} | SPI data set-up time | - | 6 | - | ns |
| t_{SPIDH} | SPI data hold time | - | 0 | - | ns |
| t_{SPIDV} | SPI enable to output data valid time | - | 2 | - | ns |
| t_{SPIOH} | SPI output data hold time | - | 0 | - | ns |
| SPI2 | | | | | |
| t_{SPIDSU} | SPI data set-up time | - | 10 | - | ns |
| t_{SPIDH} | SPI data hold time | - | 0 | - | ns |
| t_{SPIDV} | SPI enable to output data valid time | - | 2 | - | ns |
| t_{SPIOH} | SPI output data hold time | - | 0 | - | ns |

[1] T_{HCLK} = period time of SPI IP block input clock (HCLK)

11.9.2 Timing diagrams for SPI and SSP (in SPI mode)

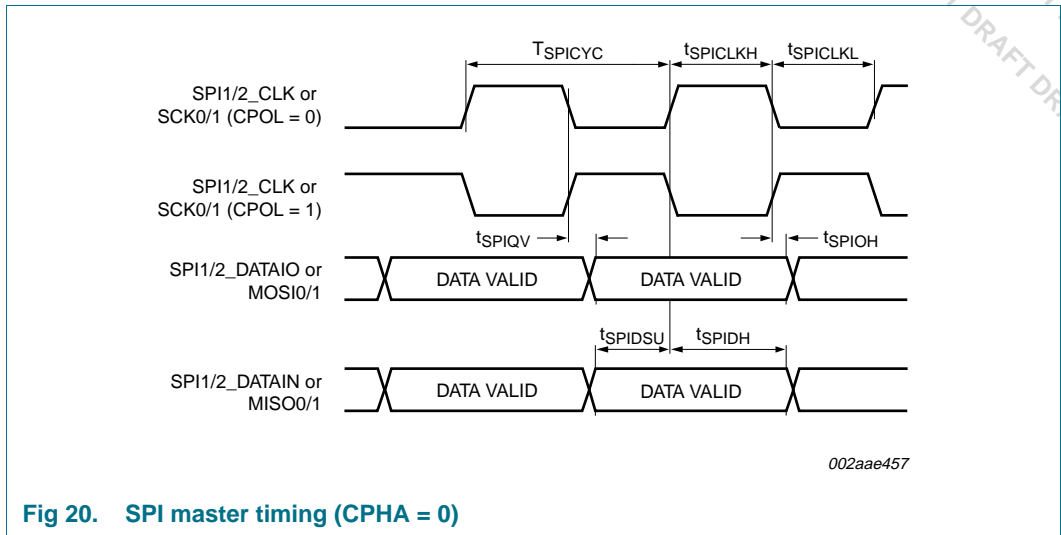

Fig 20. SPI master timing (CPHA = 0)

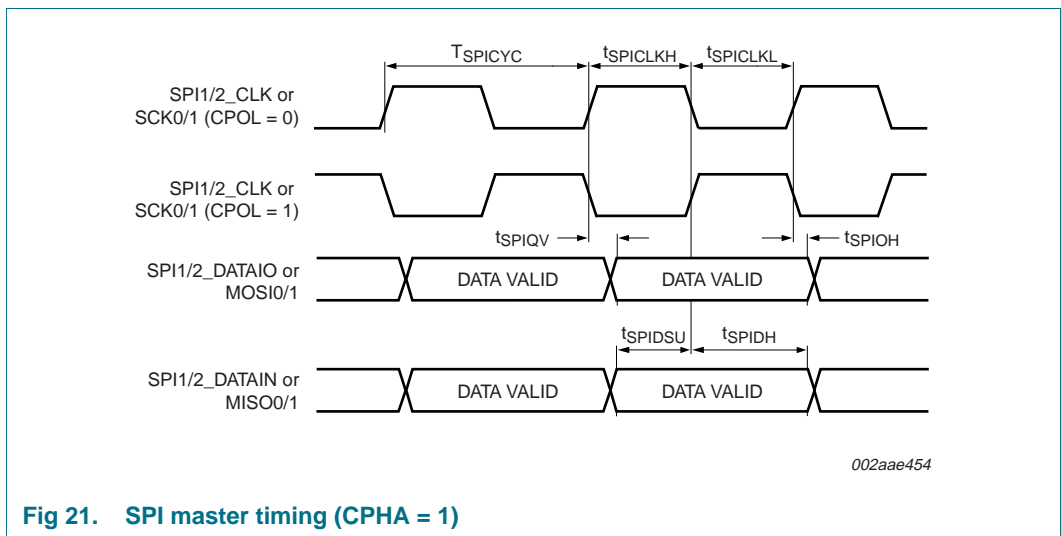
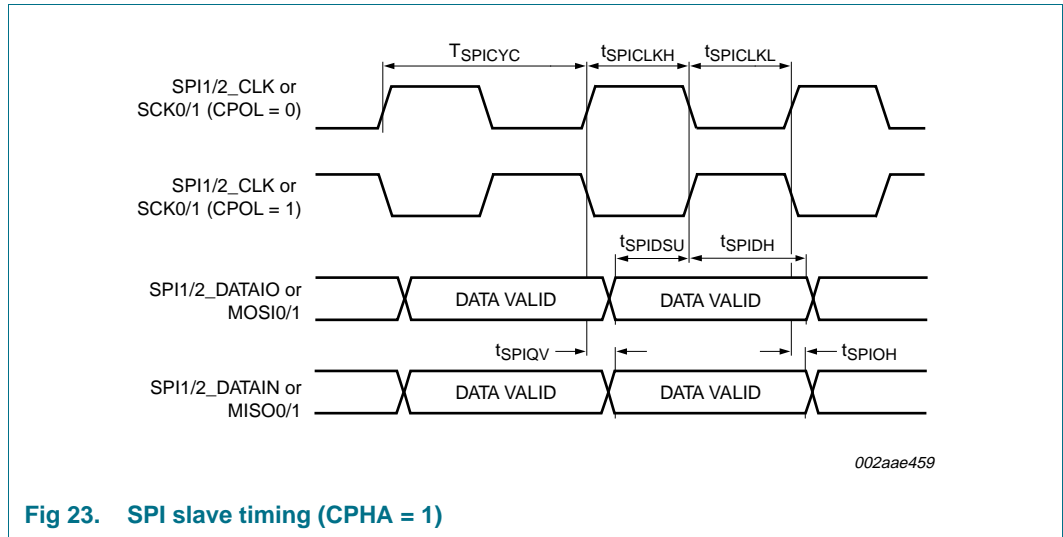
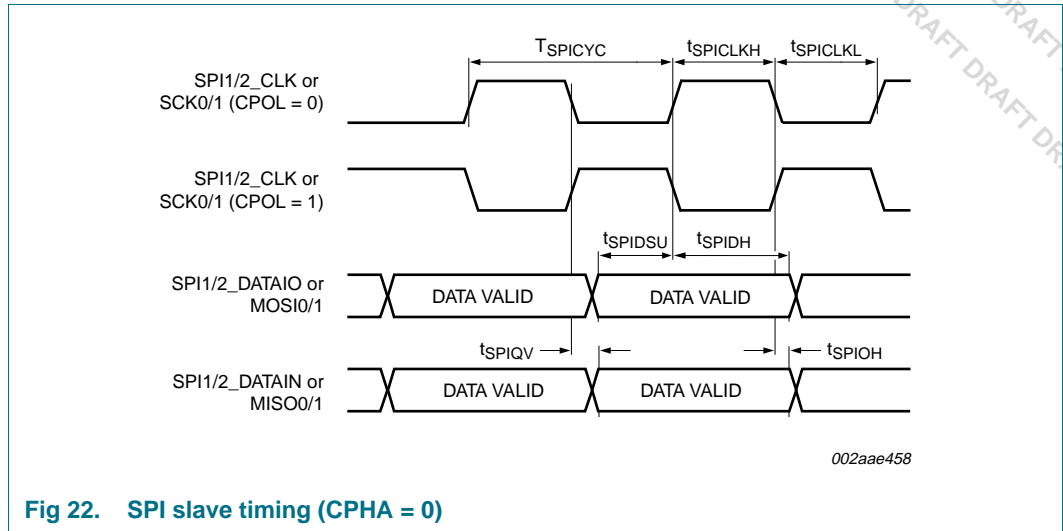

Fig 21. SPI master timing (CPHA = 1)



12. Package outline

TFBGA296: plastic thin fine-pitch ball grid array package; 296 balls

SOT1048-1

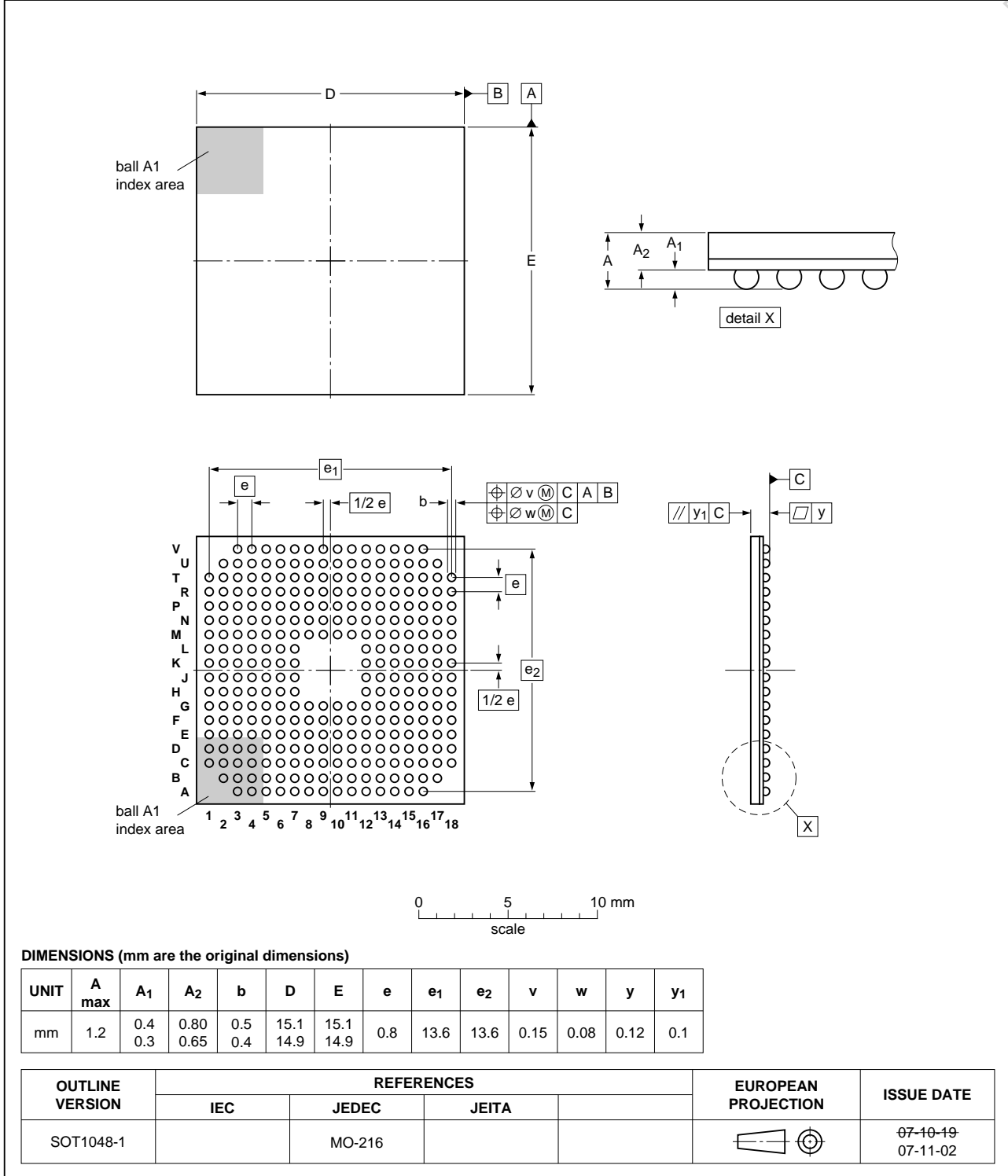

Fig 24. Package outline SOT1048-1 (TFBGA296)

13. Abbreviations

Table 20. Abbreviations

| Acronym | Description |
|-----------|---|
| ADC | Analog-to-Digital Converter |
| AHB | Advanced High-performance Bus |
| AMBA | Advanced Microcontroller Bus Architecture |
| APB | Advanced Peripheral Bus |
| CISC | Complex Instruction Set Computer |
| DDR SDRAM | Double Data Rate Synchronous Dynamic Random Access Memory |
| DMA | Direct Memory Access |
| DSP | Digital Signal Processing |
| ETM | Embedded Trace Macrocell |
| FAB | Fast Access Bus |
| FIFO | First In, First Out |
| FIQ | Fast Interrupt Request |
| GPIO | General Purpose Input/Output |
| I/O | Input/Output |
| IRQ | Interrupt Request |
| HS | High-Speed |
| IrDA | Infrared Data Association |
| JTAG | Joint Test Action Group |
| LCD | Liquid Crystal Display |
| MAC | Media Access Control |
| MIIM | Media Independent Interface Management |
| OHCI | Open Host Controller Interface |
| OTG | On-The-Go |
| PHY | Physical Layer |
| PLL | Phase-Locked Loop |
| PWM | Pulse Width Modulator |
| RAM | Random Access Memory |
| RMI | Reduced Media Independent Interface |
| SE0 | Single Ended Zero |
| SDR SDRAM | Single Data Rate Synchronous Dynamic Random Access Memory |
| SPI | Serial Peripheral Interface |
| SSI | Serial Synchronous Interface |
| SSP | Synchronous Serial Port |
| TFT | Thin Film Transistor |
| TTL | Transistor-Transistor Logic |
| STN | Super Twisted Nematic |
| UART | Universal Asynchronous Receiver/Transmitter |
| USB | Universal Serial Bus |
| VFP | Vector Floating Point processor |

14. Revision history

Table 21. Revision history

| Document ID | Release date | Data sheet status | Change notice | Supersedes |
|--|--------------|------------------------|---------------|--|
| LPC3220_30_40_50_1.02 | <tbid> | | | LPC3220_30_40_50_1 and LPC3220_30_40_50_1.01 |
| Modifications: <ul style="list-style-type: none"> • Added power consumption data (Table 8, Table 9, and Figure 5). • Changed V_{ESD} to 2500 V (HBM) and 1000 V (CDM) in Table 7. • Static memory controller: added $t_{su(DQ)}$ value in Table 12. • DDR SDRAM controller: updated t_{DQSS} value in Table 14. • Changed data sheet status to Product data sheet. • Added Table 6 "Supply domains". • Corrected pin functions for pin T14 (ADIN1/TS_XM) and pin U15 (ADIN0/TS_YM) in Table 3 and Table 4. • Parts LPC3220/01, LPC3230/01, LPC3240/01, LPC3250/01 added. • Minimum and maximum characterization data added for parameters $t_{su(Q)}$ and $t_{h(Q)}$ over temperature range $-40\text{ }^{\circ}\text{C}$ to $+85\text{ }^{\circ}\text{C}$ (see Table 14). • DDR SDRAM characteristics extended to maximum operating frequency $f_{oper} = 133\text{ MHz}$ (see Table 14). • Parameter $V_{DD(EMC)}$ table notes updated in Table 8. | | | | |
| LPC3220_30_40_50_1 | 20090206 | Preliminary data sheet | - | - |

15. Legal information

15.1 Data sheet status

| Document status ^{[1][2]} | Product status ^[3] | Definition |
|-----------------------------------|-------------------------------|---|
| Objective [short] data sheet | Development | This document contains data from the objective specification for product development. |
| Preliminary [short] data sheet | Qualification | This document contains data from the preliminary specification. |
| Product [short] data sheet | Production | This document contains the product specification. |

[1] Please consult the most recently issued document before initiating or completing a design.

[2] The term 'short data sheet' is explained in section "Definitions".

[3] The product status of device(s) described in this document may have changed since this document was published and may differ in case of multiple devices. The latest product status information is available on the Internet at URL <http://www.nxp.com>.

15.2 Definitions

Draft — The document is a draft version only. The content is still under internal review and subject to formal approval, which may result in modifications or additions. NXP Semiconductors does not give any representations or warranties as to the accuracy or completeness of information included herein and shall have no liability for the consequences of use of such information.

Short data sheet — A short data sheet is an extract from a full data sheet with the same product type number(s) and title. A short data sheet is intended for quick reference only and should not be relied upon to contain detailed and full information. For detailed and full information see the relevant full data sheet, which is available on request via the local NXP Semiconductors sales office. In case of any inconsistency or conflict with the short data sheet, the full data sheet shall prevail.

15.3 Disclaimers

General — Information in this document is believed to be accurate and reliable. However, NXP Semiconductors does not give any representations or warranties, expressed or implied, as to the accuracy or completeness of such information and shall have no liability for the consequences of use of such information.

Right to make changes — NXP Semiconductors reserves the right to make changes to information published in this document, including without limitation specifications and product descriptions, at any time and without notice. This document supersedes and replaces all information supplied prior to the publication hereof.

Suitability for use — NXP Semiconductors products are not designed, authorized or warranted to be suitable for use in medical, military, aircraft, space or life support equipment, nor in applications where failure or malfunction of an NXP Semiconductors product can reasonably be expected to result in personal injury, death or severe property or environmental

damage. NXP Semiconductors accepts no liability for inclusion and/or use of NXP Semiconductors products in such equipment or applications and therefore such inclusion and/or use is at the customer's own risk.

Applications — Applications that are described herein for any of these products are for illustrative purposes only. NXP Semiconductors makes no representation or warranty that such applications will be suitable for the specified use without further testing or modification.

Limiting values — Stress above one or more limiting values (as defined in the Absolute Maximum Ratings System of IEC 60134) may cause permanent damage to the device. Limiting values are stress ratings only and operation of the device at these or any other conditions above those given in the Characteristics sections of this document is not implied. Exposure to limiting values for extended periods may affect device reliability.

Terms and conditions of sale — NXP Semiconductors products are sold subject to the general terms and conditions of commercial sale, as published at <http://www.nxp.com/profile/terms>, including those pertaining to warranty, intellectual property rights infringement and limitation of liability, unless explicitly otherwise agreed to in writing by NXP Semiconductors. In case of any inconsistency or conflict between information in this document and such terms and conditions, the latter will prevail.

No offer to sell or license — Nothing in this document may be interpreted or construed as an offer to sell products that is open for acceptance or the grant, conveyance or implication of any license under any copyrights, patents or other industrial or intellectual property rights.

Export control — This document as well as the item(s) described herein may be subject to export control regulations. Export might require a prior authorization from national authorities.

15.4 Trademarks

Notice: All referenced brands, product names, service names and trademarks are the property of their respective owners.

I²C-bus — logo is a trademark of NXP B.V.

16. Contact information

For more information, please visit: <http://www.nxp.com>

For sales office addresses, please send an email to: salesaddresses@nxp.com

17. Contents

| | | | | | |
|----------|---|-----------|-----------|---|-----------|
| 1 | General description | 1 | 7.8.1.1 | Standard UARTs | 36 |
| 2 | Features | 1 | 7.8.1.2 | High-speed UARTs | 36 |
| 3 | Applications | 3 | 7.8.2 | SPI serial I/O controller | 36 |
| 4 | Ordering information | 4 | 7.8.2.1 | Features | 37 |
| 4.1 | Ordering options | 4 | 7.8.3 | SSP serial I/O controller | 37 |
| 5 | Block diagram | 5 | 7.8.3.1 | Features | 37 |
| 6 | Pinning information | 6 | 7.8.4 | I ² C-bus serial I/O controller | 37 |
| 6.1 | Pinning | 6 | 7.8.4.1 | Features | 38 |
| 6.2 | Pin description | 10 | 7.8.5 | I ² S-bus audio controller | 38 |
| 7 | Functional description | 23 | 7.8.5.1 | Features | 38 |
| 7.1 | CPU and subsystems | 23 | 7.9 | Other peripherals | 39 |
| 7.1.1 | CPU | 23 | 7.9.1 | General purpose parallel I/O | 39 |
| 7.1.2 | Vector Floating Point (VFP) coprocessor | 23 | 7.9.1.1 | Features | 39 |
| 7.1.3 | Emulation and debugging | 23 | 7.9.2 | Keyboard scanner | 40 |
| 7.1.3.1 | Embedded ICE | 23 | 7.9.2.1 | Features | 40 |
| 7.1.3.2 | Embedded trace buffer | 24 | 7.9.3 | Touch screen controller and 10-bit ADC | 40 |
| 7.2 | AHB matrix | 24 | 7.9.3.1 | Features | 40 |
| 7.2.1 | APB | 25 | 7.9.4 | Real-Time Clock (RTC) and battery RAM | 40 |
| 7.2.2 | FAB | 25 | 7.9.4.1 | Features | 41 |
| 7.3 | Physical memory map | 25 | 7.9.5 | Enhanced 32-bit timers/external event counters | 41 |
| 7.4 | Internal memory | 27 | 7.9.5.1 | Features | 41 |
| 7.4.1 | On-chip ROM | 27 | 7.9.6 | High-speed timer | 42 |
| 7.4.2 | On-chip SRAM | 27 | 7.9.6.1 | Features | 42 |
| 7.5 | External memory interfaces | 27 | 7.9.7 | Pulse Width Modulators (PWMs) | 42 |
| 7.5.1 | NAND flash controllers | 27 | 7.9.7.1 | Features | 42 |
| 7.5.1.1 | Multi-Level Cell (MLC) NAND flash controller | 27 | 7.9.8 | Motor control pulse width modulator | 42 |
| 7.5.1.2 | Single-Level Cell (SLC) NAND flash controller | 28 | 7.9.8.1 | Features | 42 |
| 7.5.2 | SD card controller | 28 | 8 | Basic architecture | 43 |
| 7.5.2.1 | Features | 28 | 9 | Limiting values | 44 |
| 7.5.3 | External memory controller | 28 | 10 | Static characteristics | 45 |
| 7.6 | AHB master peripherals | 29 | 10.1 | Minimum core voltage requirements | 51 |
| 7.6.1 | General Purpose DMA (GPDMA) controller | 29 | 10.2 | Power supply sequencing | 51 |
| 7.6.2 | Ethernet MAC | 29 | 10.3 | Power consumption per peripheral | 51 |
| 7.6.2.1 | Features | 30 | 10.4 | Power consumption in Run mode | 52 |
| 7.6.3 | USB interface | 30 | 10.5 | ADC static characteristics | 53 |
| 7.6.3.1 | USB device controller | 30 | 11 | Dynamic characteristics | 55 |
| 7.6.3.2 | USB host controller | 31 | 11.1 | Clocking and I/O port pins | 55 |
| 7.6.3.3 | USB OTG controller | 31 | 11.2 | Static memory controller | 55 |
| 7.6.4 | LCD controller | 32 | 11.3 | SDR SDRAM Controller | 58 |
| 7.6.4.1 | Features | 32 | 11.4 | DDR SDRAM controller | 59 |
| 7.7 | System functions | 33 | 11.5 | USB controller | 61 |
| 7.7.1 | Interrupt controller | 33 | 11.6 | Secure Digital (SD) card interface | 61 |
| 7.7.2 | Watchdog timer | 33 | 11.7 | MLC NAND flash memory controller | 62 |
| 7.7.2.1 | Features | 33 | 11.8 | SLC NAND flash memory controller | 63 |
| 7.7.3 | Millisecond timer | 33 | 11.9 | SPI and SSP Controller | 67 |
| 7.7.3.1 | Features | 33 | 11.9.1 | SPI | 67 |
| 7.7.4 | Clocking and power control features | 34 | 11.9.2 | Timing diagrams for SPI and SSP (in SPI mode) | 68 |
| 7.7.4.1 | Clocking | 34 | 12 | Package outline | 70 |
| 7.7.4.2 | Crystal oscillator | 34 | 13 | Abbreviations | 71 |
| 7.7.4.3 | PLLs | 34 | 14 | Revision history | 72 |
| 7.7.4.4 | Power control modes | 35 | 15 | Legal information | 73 |
| 7.7.4.5 | Reset | 35 | 15.1 | Data sheet status | 73 |
| 7.8 | Communication peripheral interfaces | 35 | | | |
| 7.8.1 | UARTs | 36 | | | |

