

Smoke Detector Solution Based on Philips 89LPC9107

1. Introduction

If we can reliably monitor the smoke density for a working site, we can prevent and minimize the damage of fire accidents and thus reduce the cost of property damage and loss of human life. The most commonly used detectors are the ionization detectors and the photoelectric detectors. Ionization detectors are prone to malfunction when used in noisy, dusty, or damp environments and, thus, are subject to frequent maintenance. Ionization detectors also produce radiation pollution. Therefore, the popularity of ionization detectors has been on decline while photoelectric detectors are increasing in popularity. Photoelectric detectors register the intensity of ultraviolet light pulses that are reflected from the smoke in order to reduce the density of the smoke accordingly.

In the smoke detection industry, many domestic and foreign companies use the SystemSensor 2-wire bus. **The bus 24V is used to generate 10V for the detector and 3.3V for the MCU.** The detector transmits the related data to the main units by a constant current pulse. The main unit receives the detector data samples and communicates with these detectors via a polling mechanism. Then the main unit processes this data and raises the alarm.

2. Hardware Block Diagram

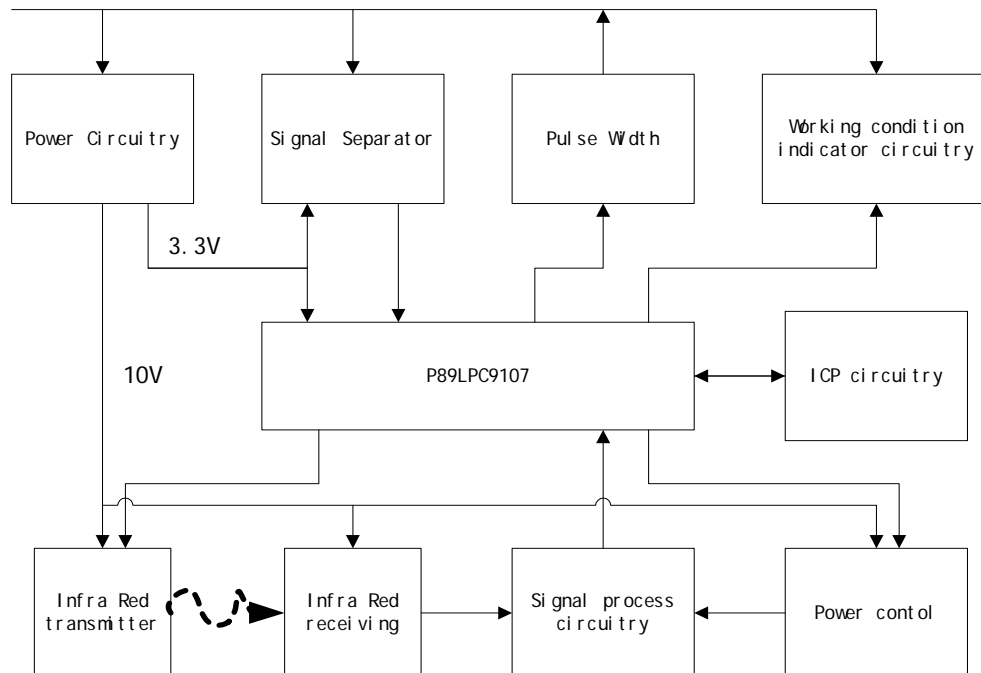

Power Circuitry: Power is supplied from the SystemSensor bus main circuit supply power.

The 10V supply for the infrared transmitter/receiver is generated via a simple constant voltage circuit output. The MCU 3.3V supply is generated via an LDO.

Signal Separator: This block separates the power and signal voltages and sends the system data to the MCU.

Pulse Width: This block will receive 5 pulse width cycles, convert the signal to a constant current pulse width, send it through the SystemSensor, and then send it back to the main controller.

Working Condition Indicator Circuitry: This block is used to indicate the working condition and status of the smoke detector. In normal conditions, the indicator will blink. During a fire alarm, it will be constantly on.

Infrared Transmitter: This block sends the infrared pulse signals.

Infrared Receiving: This block receives the infrared signals reflected by the smoke. It then converts the light signals to a pulse signal.

Signal Process Circuitry: This circuitry is used to amplify and filter the voltage signal output from the infrared receiver.

Power control: This block is used for MCU power control.

ICP circuitry: This block is used for MCU software download.

3. Work Flow of Each Circuitry.

As shown in figure 1, resistor R1 and Z2 form a constant voltage series circuit. The 24V from the SystemSensor main circuit is used to produce an 11V stable voltage. The circuit transistor Q1 current amplifier, diode D3, D2 isolation, capacitor C4, and C3 filters this to produce two rails of stable 10V voltage. One of the 10V rails will be used as V_{DD} to supply the infrared transmitter, the infrared receiver, and the signal control circuitry power. The other 10V rail is passed to a low power consumption, LDO HT7133, to produce a stable 3.3V voltage V_{cc} to supply the signal separator circuitry and MCU 89LPC9107.

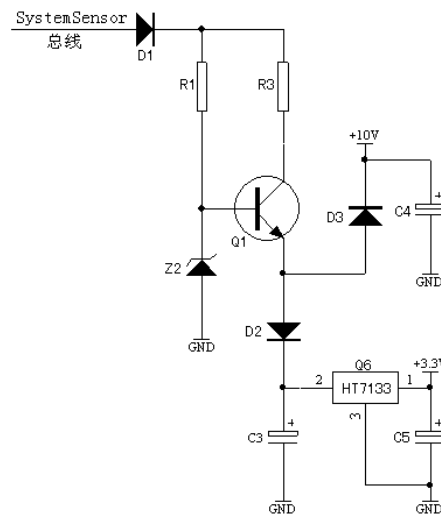

Figure 1: Power Circuitry

As shown in Figure 2, resistor R10, R4, R2, R13, Zener diode Z1 (11V), capacitor C6, and transistor Q2 form a splitter circuit by which the SystemSensor's 24V and non-24V signal levels are separated. 24V signals output logic "0" and non-24V signals output logic "1".

Resistors R11, R12, R14, R5, diode D4, capacitor C7, and transistor Q7, form a 0V signal two value separator circuitry.

The SystemSensor bus can have three voltage levels: 24V, 5V, and 0V. The circuit in Figure 2 isolates these voltages, as shown in the table below:

Bus Voltage	24V Isolation Output	0V Isolation Output
24V	0	0
5V	1	0
0V	1	1

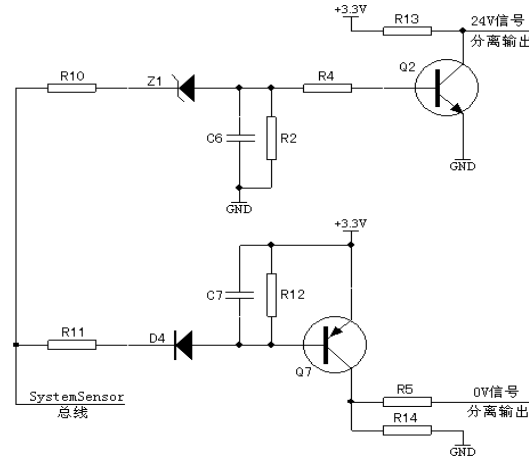

Figure 2: Signal Separator

As shown in Figure 3, transistors Q3, Q4, resistors R27, R29, and capacitor C9 form a simple constant current circuit. When “pulse width” is in the high state, the SystemSensor main circuit will produce a current pulse signal. By measuring the current pulse value, the return value data size can be determined.

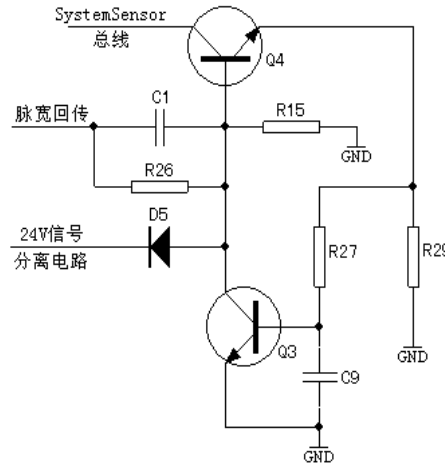

Figure 3: Pulse Width

As shown in figure 4, the infrared pulse transmitter circuit consists of the resistor R23, R24, R30, transistor Q9, and emitting diode. The 89LPC9107 can control and generate a few nanoseconds of an infrared pulse signal. The infrared receive circuit is based on resistor R25, R31, receiver H3, and capacitors C11, C10. Amplification is achieved using U2C, resistor R34, R32, and the voltage adjustor R33. The capacitor, C12, and resistor, R8, filter the output to give a better signal edge. Via the R9 and C8 low pass filter, the signal will be sent to U2D and to the resistors R35 and R36 to form a post-amplifier circuit. Finally, the backend amplifier circuit will send its output to the 89LPC9107 A/D input terminal. The MCU integrated A/D converter will complete the light pulse signal sampling. In the diagram, the resistors R17, R18, R19, R20, and transistors Q8, Q10 will make up the power control for the signal control circuit. Only during the signal sampling time will the power supply be turned on. At all other times, the signal control circuit power will be turned off in order to reduce the power consumption of the system.

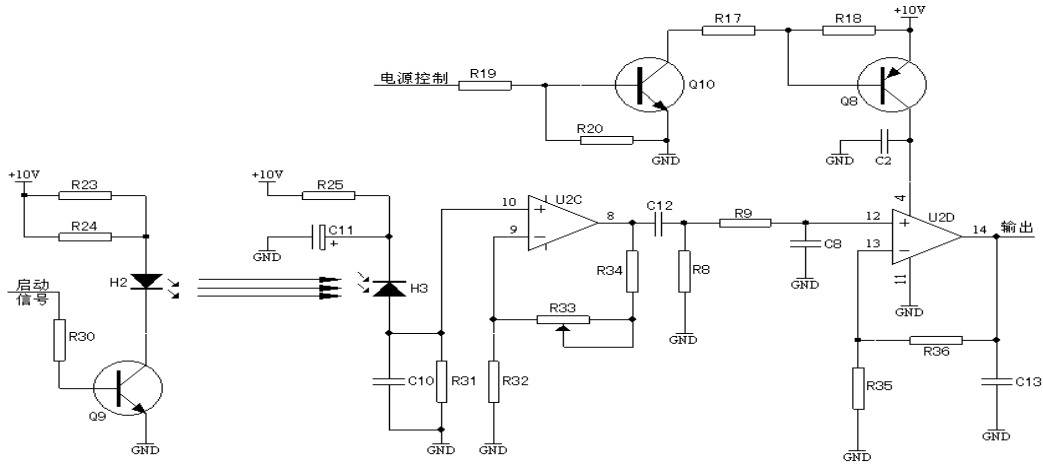

Figure 4: Infrared Transmitter, Receiving, Signal Separator

As shown in Figure 5, the core of the smoke detector is implemented using an 89LPC9107. The 89LPC9107 system clock source is selected by the MCU internal 400 KHz watchdog timer. To reduce the detector's static power consumption, we use the internal settings of the MIC's DIVM to obtain the clock cycle of 200 KHz by dividing the 400 KHz watch dog timer frequency. During this time, the detector's static consumption is less than 250 uA. In the diagram, the resistor R6, capacitor C14, and transistor D6 make up the reset circuit for the 89LPC9107. For convenient program download, the design reserves the ICP connector circuit. In the diagram, the connector J1 is the ICP download connector. This is implemented using the 4-bit double row pin, which is used for burning the user code to 89LPC9107. In the diagram, jumpers JP1, JP2, JP3, and JP4 are used to switch the reset signal, power source, PDA signal, and PCL signal of the MCU. When ICP download is required, the jumper should be shorted (terminal 2 and 3 in the diagram should be shorted). During this time, the MCU's reset signal, power, PDA signal, and PCL signal only connect to the J1 connector and are disconnected from the other circuit. Now, it is possible to use J1 to finish the program burning. When you need to run the program, the above 4 jumpers should be connected to the "OFF" status by shorting terminals 1 and 2, as shown the diagram. Now, the reset signal, power, PDA signal and PCL signal will connect to the related circuit.

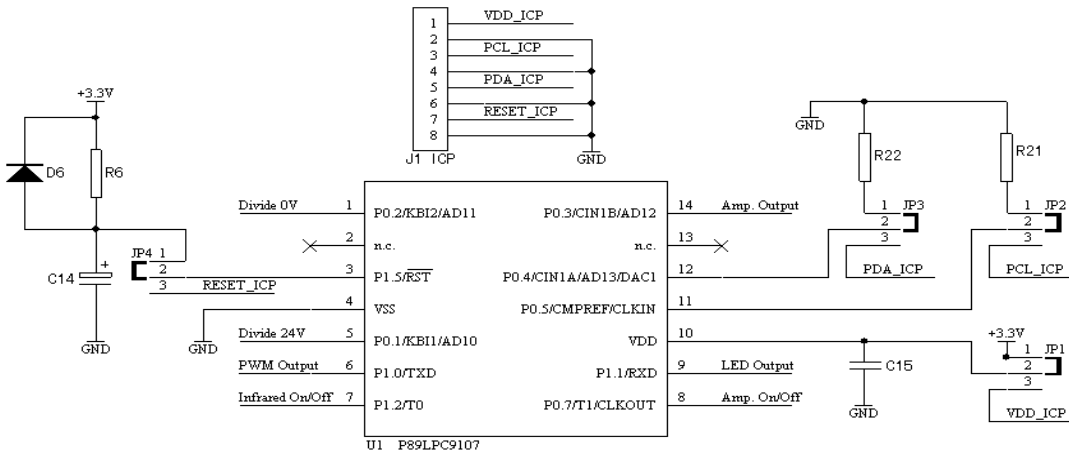

Figure 5: ICP Interface Circuit