

AN10936

Photovoltaic MPPT battery charge controller using the MPT612 IC reference board

Rev. 2 — 2 February 2011

Application note

Document information

Info	Content
Keywords	Solar, PV, MPPT, MPT612, PWM, DC-DC converter, buck, boost, buck boost, PWM, UART, I2C-bus, GPIO, LQFP, ARM7TDMI-S, flash, SRAM, ADC, JTAG, EmbeddedICE, FIFO, PLL, LED, power converter, BOM
Abstract	This application note describes how to develop a buck-boost enabled solar PV MPPT charge controller using the MPT612 reference board. In addition, it describes how to test and benchmark the controller with other designs.



Revision history

Rev	Date	Description
2.0	20110202	<ul style="list-style-type: none">Graphics updated: Figure 9(a), Figure 9(b), Figure 10(a), Figure 10(b), Figure 11, Figure 12, Figure 13.Section 12 “Steps to link and test new applications”: contents replaced with web link.Corrected: several typographical errors throughout document.
1.0	20100902	Initial version

Contact information

For more information, please visit: <http://www.nxp.com>

For sales office addresses, please send an email to: salesaddresses@nxp.com

1. Introduction

1.1 Solar photovoltaic energy and maximum power point

Dwindling fossil fuel resources and the adverse environmental effects arising from converting these resources into energy have placed increasing focus on the use of non-fossil fuel energy sources such as solar energy.

Solar illumination can be converted into electrical energy through solar cells and the energy generated is called PhotoVoltaic (PV) energy. While the sun as a source is available for free, generating PV energy is expensive. This makes it important to extract the maximum PV energy from the incident sun light using the solar cells.

Typical solar cells comprise a PN junction made of a semiconductor material such as silicon. Since the power from a single cell is too small to be of practical use, cells are connected in series-parallel fashion to realize higher power, voltage and current. These are called solar panels or modules. PV panels are rated in terms of peak-watt at standard test conditions (25 °C, 1000 W/m² power density and spectrum of AirMass 1.5).

A solar PV panel has the current/voltage/power characteristics shown in [Figure 1](#).

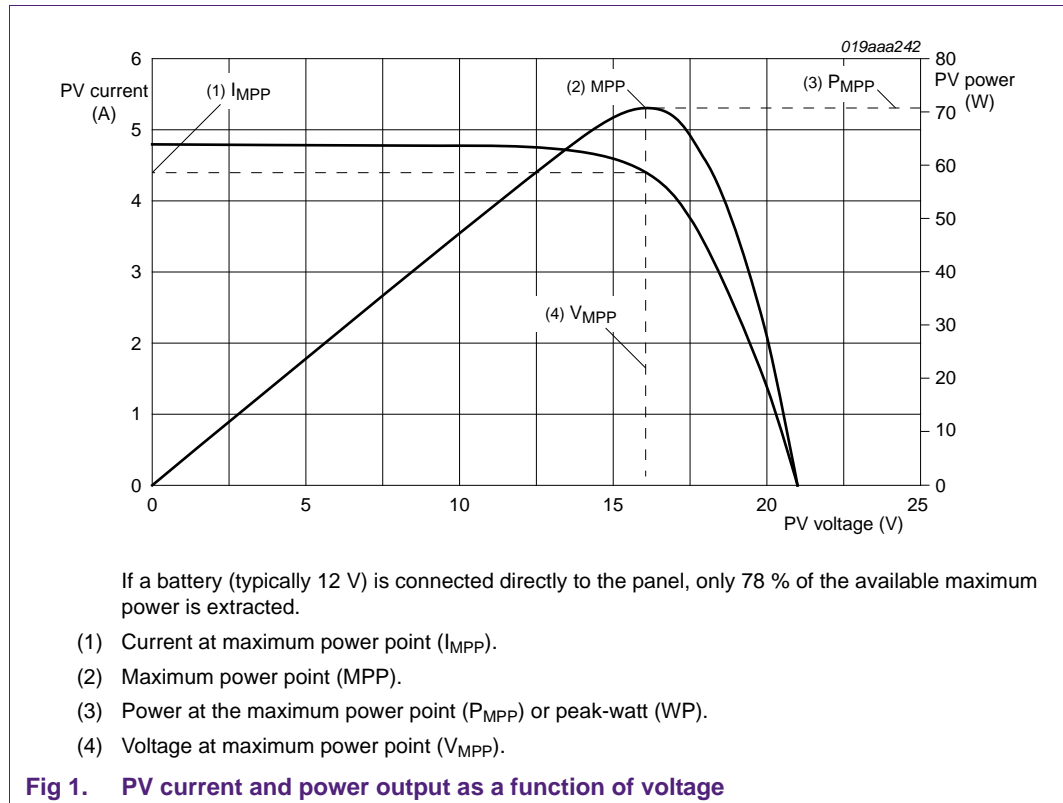

There is a specific PV voltage at which the power delivered by the PV panel is the highest. On the curve the point at which the power is the maximum is called the power at the maximum power point (P_{MPP}) or peak-watt (WP). The voltage at MPP is called the maximum power point voltage (V_{MPP}) and the current is called the maximum power point current (I_{MPP}). In [Figure 1](#), P_{MPP} is 70 W, V_{MPP} is 16.2 V and I_{MPP} is 4.3 A.

If the solar panel operates at its MPP, maximum power can be extracted from the panel. Operating the panel at any other point amounts to under utilization of the PV power available and thus inefficient use of expensive PV power. Tracking the MPP of a PV panel (DC source) is called the Maximum Power Point Tracking (MPPT). MPPT and ensuring that the panel operates at this MPP helps maximum utilization of the installed PV capacity.

1.2 Solar charge controller

The PV power extracted can be used:

- To directly power a DC load
- To be converted to AC using an inverter to drive an AC load
- To charge an energy storage device (battery, super capacitor etc.) enabling the power to be used on demand

This application note focuses on charging batteries from a PV panel using an MPPT-enabled charge controller.

Typically a charge controller performs the following basic functions:

- Controls maximum power extraction from a panel by tracking the MPP and ensuring that the panel operates at MPP
- Controls battery charging as defined in the battery charge cycle specification to improve usable battery life and protect it against reverse connection, over charging and deep discharging
- Load protection against overloads and short-circuits
- LED or LCD Status indications
- Communication of system parameters to external systems using dedicated interfaces

Depending on the topology of the power electronics, an MPPT charge controller can be either:

- **Buck only** – the PV voltage must be higher than the battery voltage
- **Boost only** – the PV voltage must be lower than battery voltage
- **Buck-boost** – both the PV voltage and battery voltage can be variable values with the system switching between buck and boost based on the relative voltages

A simplified illustration of a solar battery charging system is shown in [Figure 2](#).

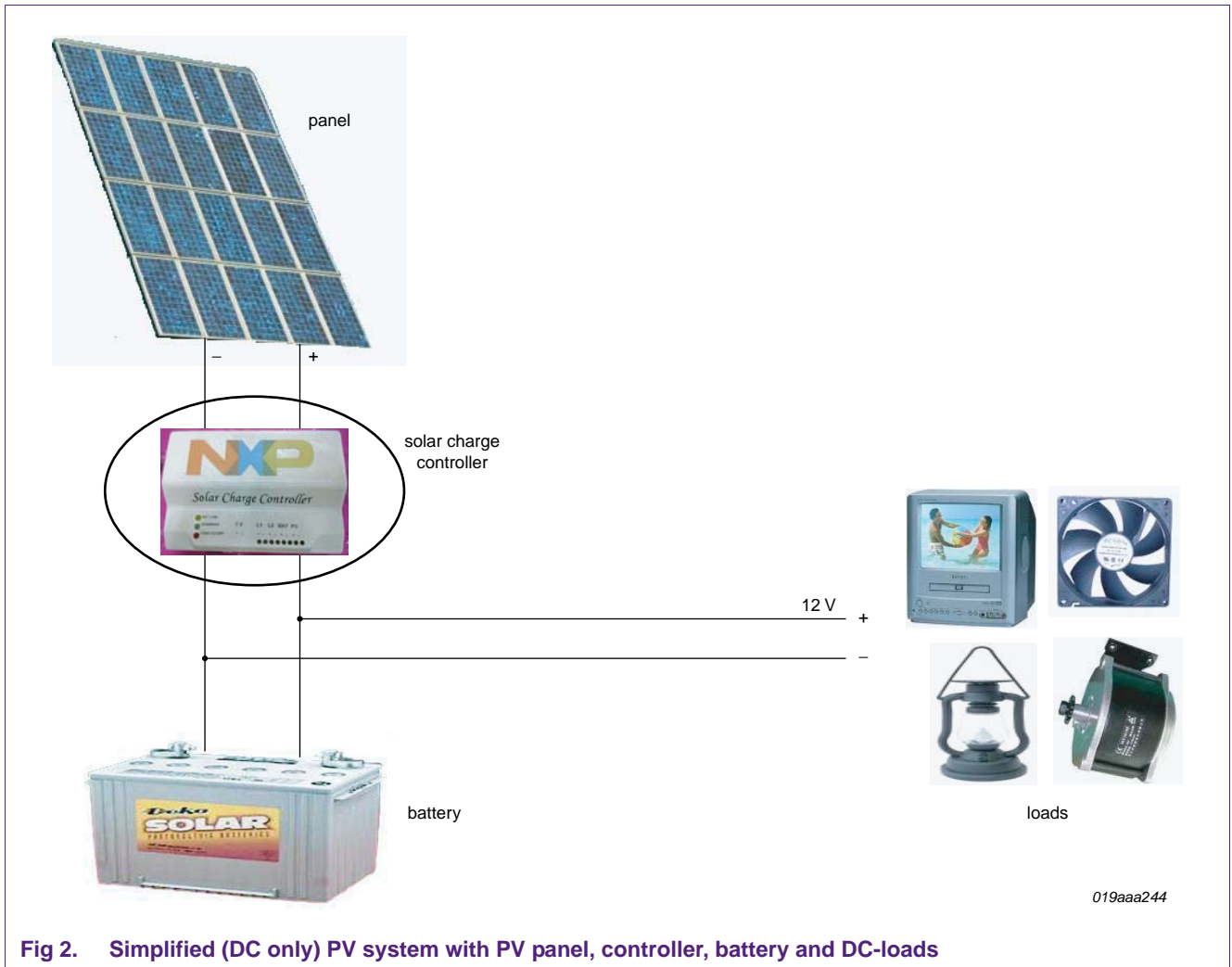

Fig 2. Simplified (DC only) PV system with PV panel, controller, battery and DC-loads

2. MPT612 IC

The MPT612 is an IC developed for Maximum Power Point Tracking (MPPT) applications to extract the maximum power from a source such as a PV panel or fuel cell. The ICs primary function is to track the MPP of the source based on the voltage and current. The resulting Pulse-Width Modulated (PWM) output is sent to the MOSFET to control the device switching, enabling the system to operate at MPP.

Utilizing a patent pending MPPT algorithm defined in the embedded software, the MPT612 provides up to 15 kB of on-chip high-speed flash memory enabling enhanced functionality using user software. Serial communication interfaces such as UART, SPI, SSP and I²C-bus make the MPT612 ideally suited for integrating with real world systems.

The MPT612 is based on the ARM7TDMI-S 32-bit RISC core and operates at up to 70 MHz. Housed in a 48-pin LQFP IC package, the MPT612 provides a number of standard software libraries for implementing the PV MPPT function and several other optional functions as shown in [Figure 3](#). See the *MPT612 data sheet* for full details on the MPT612.

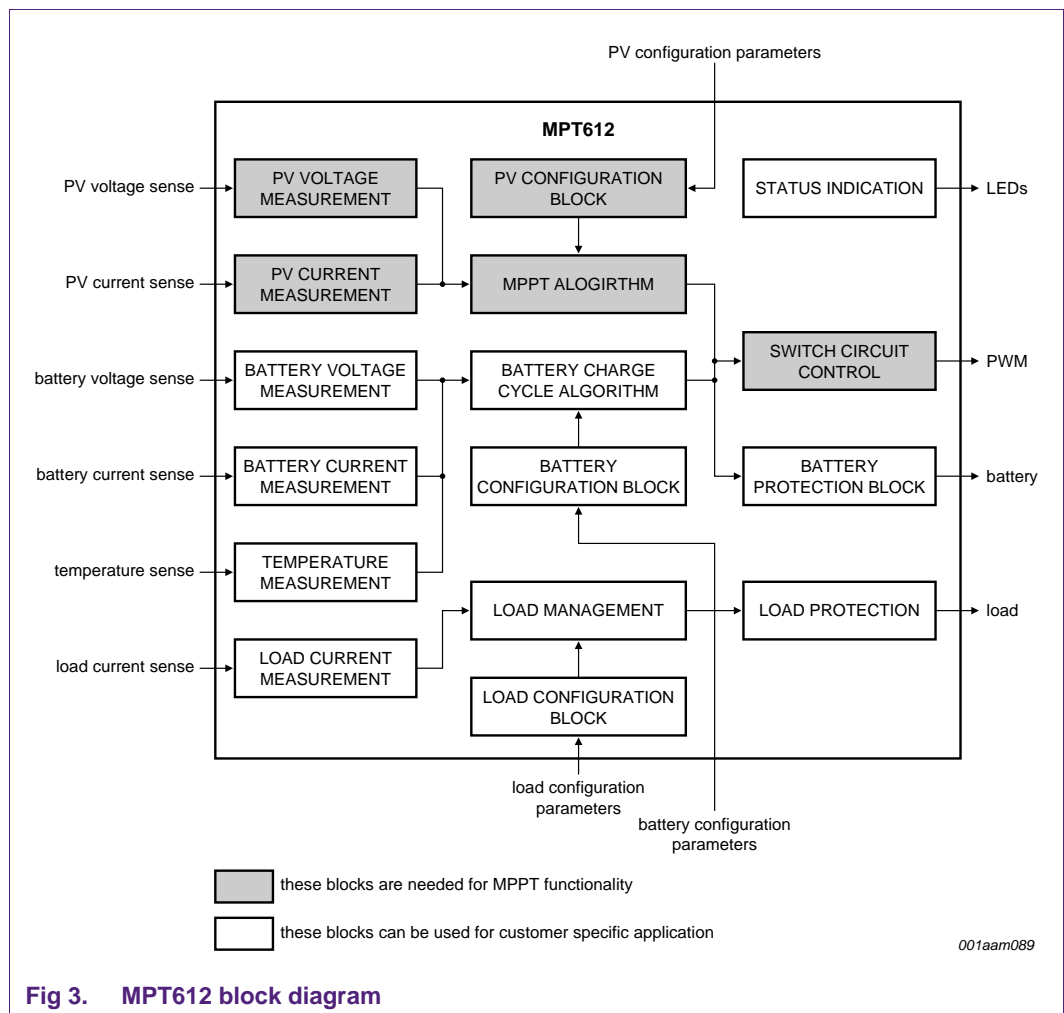

3. MPT612 software

The MPT612 is bundled together with the software libraries for the MPPT function. The high level software architecture of the IC is shown in [Figure 4](#).

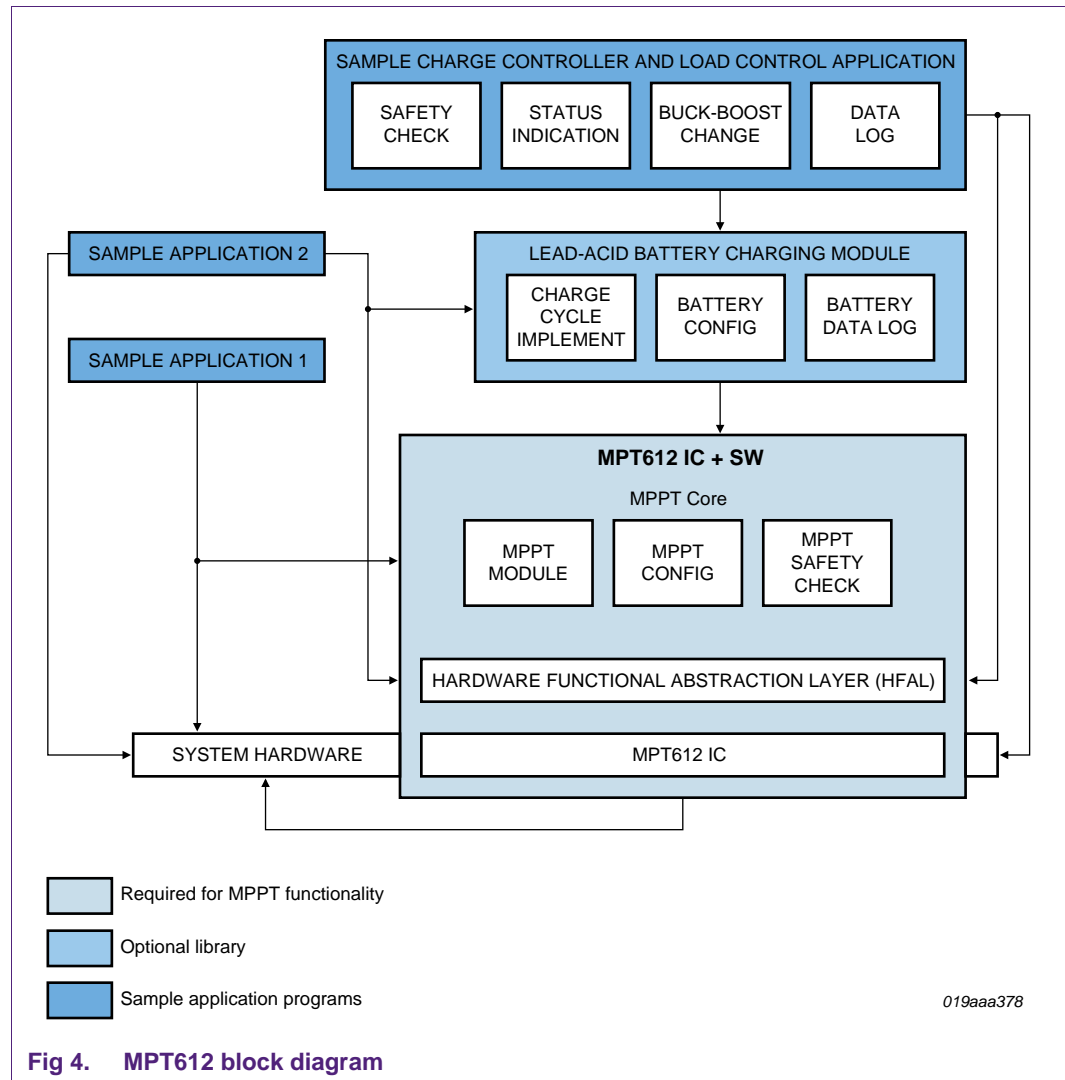

Fig 4. MPT612 block diagram

The MPT612's software consists of the following:

- **Hardware Functional Abstraction Layer:**
 - This layer contains the abstraction of services for different peripherals
 - Will be used by the different layers including MPPT Core and other application layers
 - This layer exports APIs for registering the callbacks that will be called periodically
 - APIs are exported for peripherals such as ADC, PWM, interrupts/UART and functions that are helpful in application layers such as software timer

- **MPPT Core:**
 - MPPT Core is the main layer that implements the MPPT algorithm (patent pending)
 - This layer always tracks the MPP (Maximum Power Point) when enabled
 - The APIs exported by this block, should be called by the application to control the functionality of the MPPT Core
 - The application over this layer sends the configuration to the MPPT Core, which in turn works within those configuration parameters

The optional lead-acid battery charging module is explained in the *MPT612 data sheet*. This software is also used in the MPPT charge controller reference design.

The application software developed for the MPPT charge controller reference design has the following features:

- This application software implements the product requirements for a sample charge controller that controls the load and charges the battery
- The main functionality of this software invokes the MPPT Core and lead-acid battery charging layers at an appropriate time as required. This application manages the safety check of the system
- It also indicates the status of the charge controller
- Logs the relevant data into flash memory for further action

3.1 Software memory size

Table 1. Software memory size

Part	Memory type	Size
Total memory in MPT612 IC	flash memory	32 kB
	SRAM	8 kB
Memory used for HFAL, MPPT Core and lead-acid battery charging, excluding debug code		
MPPT Core (whole layer)	ROM	7 kB
	RAM	1.2 kB ^[1]
HFAL	ROM	8 kB ^[2]
	RAM	1.2 kB
Lead-acid battery charging module	ROM	3.5 kB
	RAM	1.2 kB

[1] 1 kB is allocated for stack, which may be reduced.

[2] Includes scheduler, PWM, ADC, IRQ, GPIO, timer, flash, data logging, LED module etc.

4. MPPT charge controller reference system

The MPT612 and its associated software functionality can be demonstrated using an MPPT enabled solar battery charge controller. This application note describes the design and development of a charge controller specifically focusing on making optimal use of the features and functionality of the MPT612 IC and software.

The charge controller takes power from a solar PV panel and charges the battery as defined in the battery charge cycle specification. It also enables the battery supplying power to the DC loads connected to the controller. Apart from this, a number of protection mechanisms, system status indications, configurability and communication facilities are implemented.

To ensure ease and safe use, a number of configuration parameters are available which control protection mechanisms, system status indications and communication interfaces.

4.1 System specifications

The charge controller specifications are described in [Table 2](#).

Table 2. MPPT charge controller reference design specifications

$T_{amb} = 25\text{ }^{\circ}\text{C}$; parameters marked with * can be configured.

Feature and parameter	Value
Input	
Minimum input voltage at MPP*	10 V
Nominal PV voltage	12 V
Maximum PV voltage*	27 V
Maximum PV current	6 A
Maximum PV module power rating	100 W
Connector type	2-terminal; screw type
Battery	
Battery type*	lead-acid
Nominal battery voltage	12 V
Maximum charging current	6 A
Charge cycle*	3-stage in CC and CV modes define modes
Battery boost on voltage*	12.7 V \pm 0.3 V
Battery boost off voltage*	15.3 V \pm 0.3 V
Battery float on voltage*	13.8 V \pm 0.3 V
Battery float off voltage*	14.6 V \pm 0.3 V
Load disconnect voltage*	10.8 V \pm 0.3 V
Load reconnect voltage*	12.2 V \pm 0.3 V
Battery low alarm on voltage*	11.4 V \pm 0.3 V
Battery low alarm off voltage*	11.6 V \pm 0.3 V
Connector type	2-terminal; screw type

Table 2. MPPT charge controller reference design specifications ...continued
 $T_{amb} = 25\text{ }^{\circ}\text{C}$; parameters marked with * can be configured.

Feature and parameter	Value
Load	
Load DC voltage	same as battery voltage
Maximum load current	8 A
Number of load connectors	2
Load connector type	2-terminal; screw type
Protection functions	
PV reverse polarity protection	yes
PV reverse current flow protection	yes
Surge/transient protection	1.5 kVA
Stop charging at high temperature*	50 °C
Battery low voltage/deep discharge protection*	10.8 V
Battery reverse polarity protection	yes; 12 A fuse
Battery short-circuit protection	yes; 12 A fuse
Battery open protection	yes; system is not on if the battery is not connected
Load cut-off current overload for 500 ms*	10 A
Load cut-off current short-circuit	10 A
Indicators	
System status indication (3 LEDs)	green blinking: battery fully charged
	green on: battery charging
	yellow blinking: battery low
	red on: battery low or overload cut-off
Self consumption	
Maximum controller standby current; no load; PV voltage is zero	10 mA
Configuration	
System reset	push button switch
Configuration methodology	via UART
Communication	
Data readout	via UART
Environmental	
Ambient temperature range	0 °C to 50 °C

4.2 MPPT charge controller reference system block

The block diagram of the MPPT charge controller reference system is shown in [Figure 5](#). The major functions of the reference design are sensing/measuring PV voltage and current, MPPT algorithm implementation (including PV power calculation, tracking the maximum power dynamically and ensuring that the required PWM output is supplied to the gate drive circuit of the switching MOSFET), DC–DC conversion using the buck-boost topology (which incorporates switching between buck and boost operation based on the relative voltage levels of PV and battery), load current sense and overload protection, system configuration (as needed through the UART) and communication of salient parameters to user as required.

In addition, the charge controller system temperature is measured and battery charging stopped, if the controller’s ambient temperature rises above a certain predefined value (50 °C in this example).

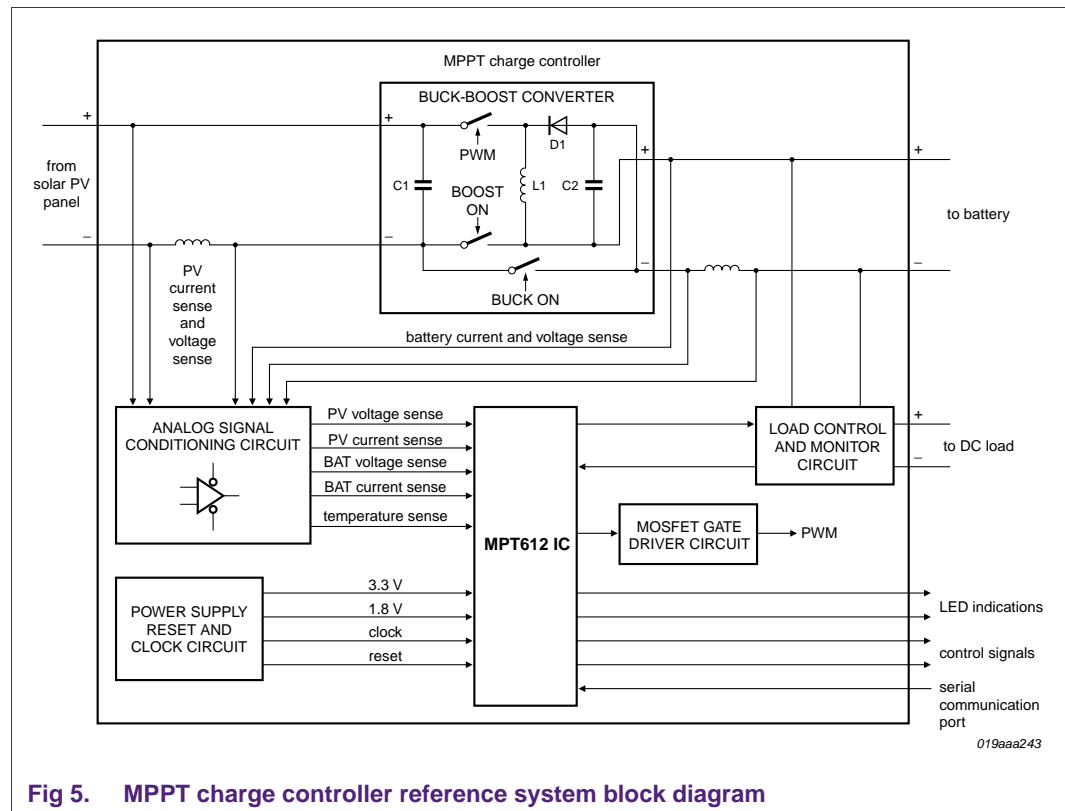

Fig 5. MPPT charge controller reference system block diagram

5. Schematics

5.1 Charge controller reference system boards

The MPT612 MPPT charge controller reference system is implemented using a 2-board approach to minimize the charge controller Bill Of Materials (BOM) and cost.

- The charge controller board takes PV power, charges the battery and supplies power to loads
- The JTAG/UART add-on board is used exclusively for configuration and data logging

The charge controller board is needed for every PV system. However, the JTAG/UART add-on board is typically used by service providers sparingly. One JTAG/UART add-on board can be used with multiple charge controller systems. Separating the JTAG/UART configuration and data logging functionality from the main PV charge controller reduces the size and cost of the charge controller board.

[Figure 6](#) shows the charge controller reference system with the charge controller board and the JTAG/UART add-on board connected.

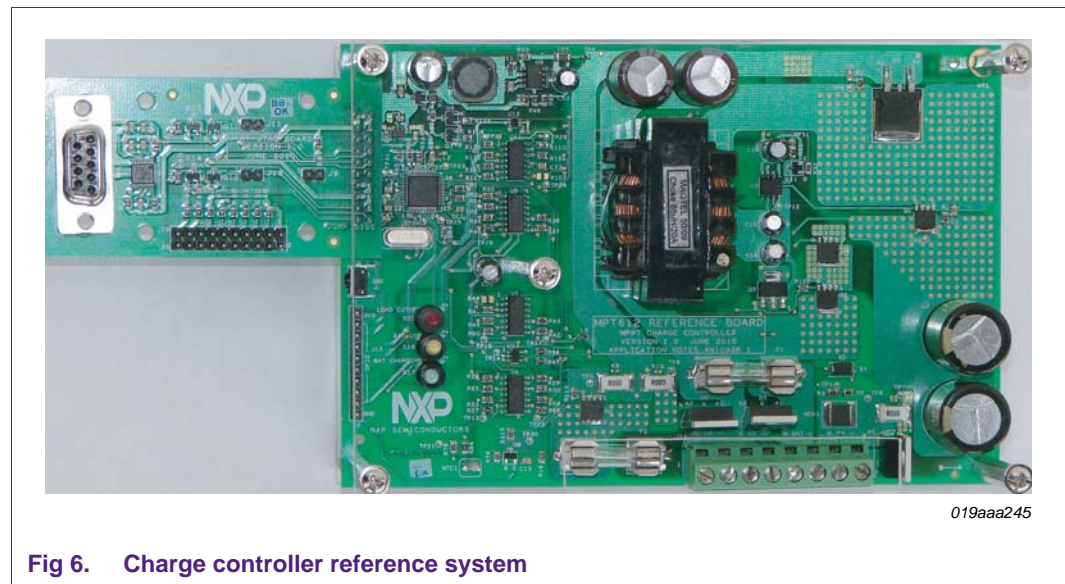

Fig 6. Charge controller reference system

5.1.1 Charge controller board

The charge controller board takes the required input from the PV panel, supplies the charging current to the battery and facilitates load supply from battery to load. It also implements all protection functions as specified in [Table 2 on page 9](#).

This charge controller board has one 8-pin input connector used for interfacing to all the external systems (such as the PV panel, battery and loads).

The optional JTAG/UART add-on board can be connected to the JTAG/UART connector to enable system configuration and data retrieval.

The charge controller board is shown in [Figure 7](#).

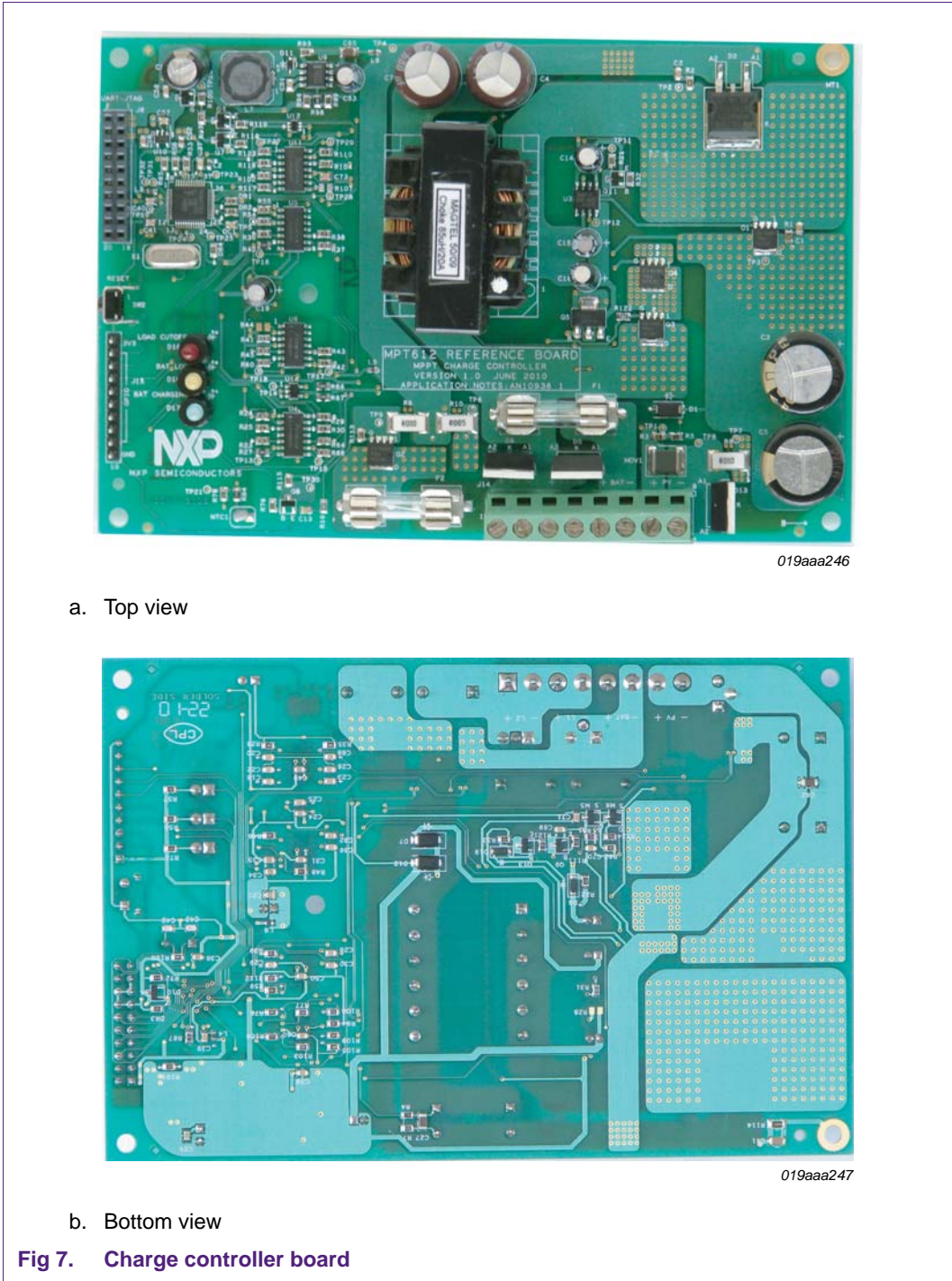

019aaa246

019aaa247

5.1.2 JTAG/UART add-on board

The add-on board is needed for configuring any of the configurable parameters (highlighted with an * in [Table 2 on page 9](#)). This add-on board is also needed for extracting any data/information like PV voltage, current, and power from the charge controller for analytical purposes.

The JTAG/UART add-on board is shown in [Figure 8](#).

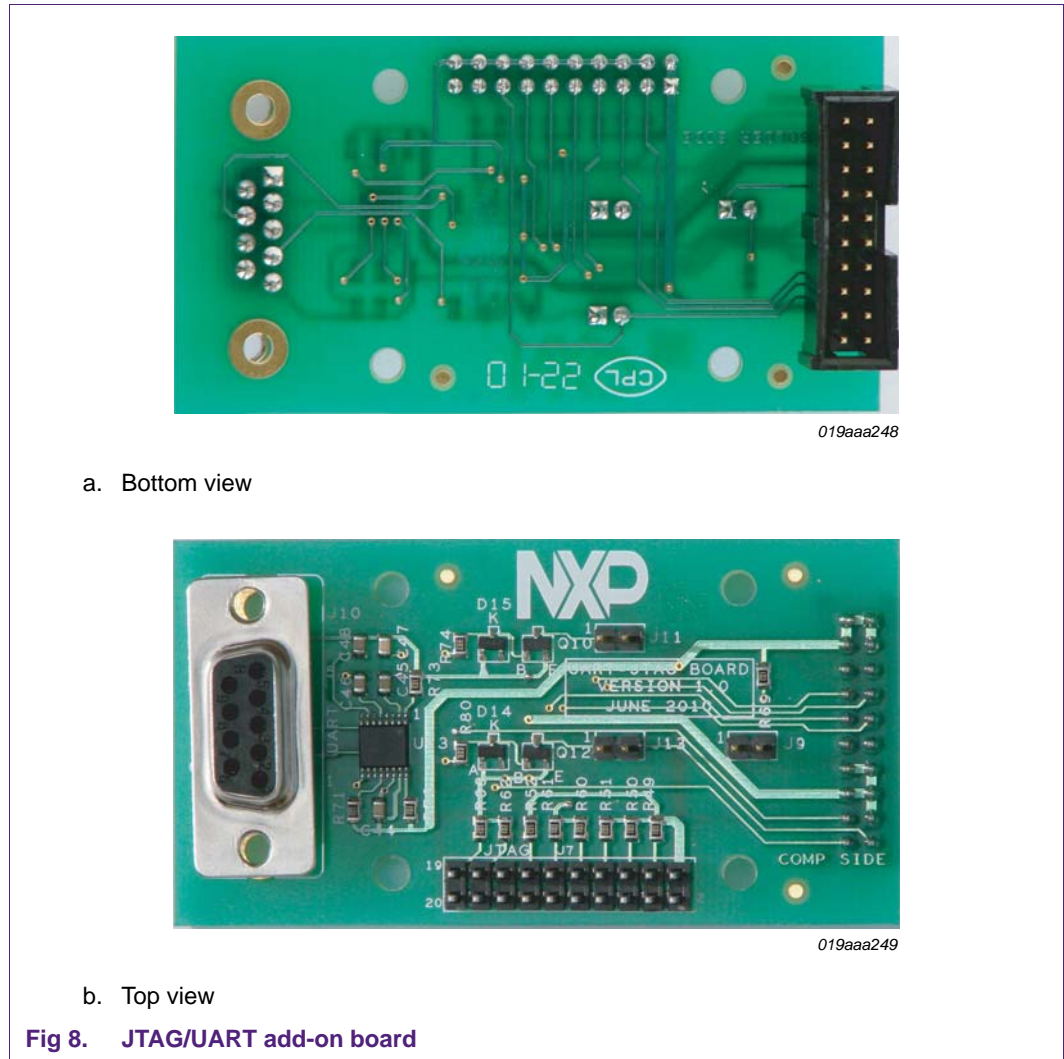

5.2 Charge controller reference system; major circuit blocks

Major circuit blocks of the charge controller board are:

- PV voltage and current sense circuit
- Battery voltage and current sense circuit
- DC-DC buck-boost converter power electronics circuit
- MPT612 digital circuit
- Board power supply circuit
- JTAG/UART optional add-on circuit

5.2.1 PV voltage and current sense circuit

The PV voltage and current sense circuit is shown in [Figure 9](#). Input to the PV voltage sense circuit is from resistor dividers R3 and R5 shown in [Figure 11](#). Two separate PV voltage sense circuits are used: buck mode and boost mode voltage sense.

- **Boost mode:** quad op amps U4A and U4B with associated circuits are used for the PV voltage sense in boost mode with a gain of 1.1.
- **Buck mode:** quad op amp U4C is used for PV voltage sense in buck mode with a gain of 2.

Accurate measurement of PV current is important for latching to the maximum power point. The current monitor IC U14 with a gain of 50 is used for PV current sense. The low-pass filters formed by quad op amps U4A and U4D with their associated circuits are used for filtering the noise.

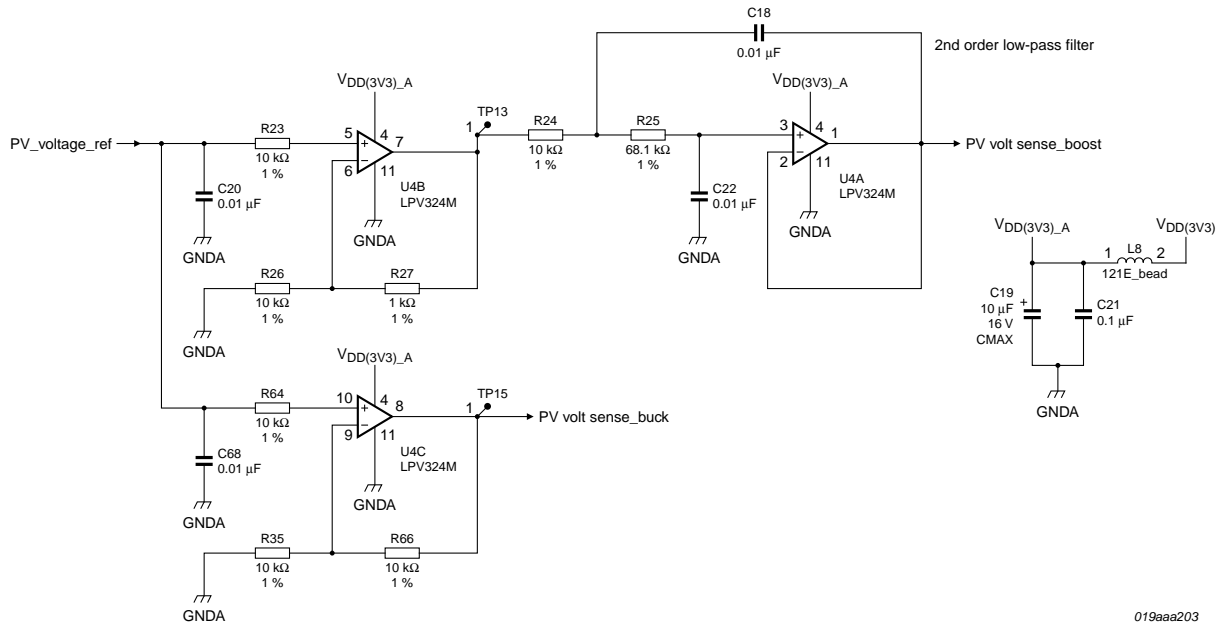

a. PV voltage sense circuit

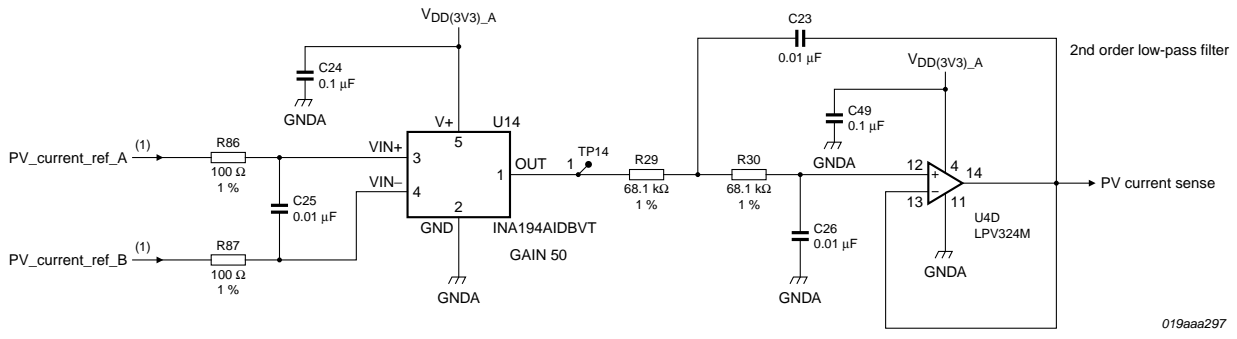

b. PV current sense circuit

V_{DD(3V3)_A} is a 3.3 V analog supply.

(1) Keep ref_A and ref_B track the same length with differential routing.

Fig 9. PV voltage and current sense circuit schematics

5.2.2 Battery voltage and current circuit

The battery voltage and current sense circuit is shown in [Figure 10](#). The battery voltage sense circuit input is generated by the resistor divider R4 and R7 shown in [Figure 11](#). The battery voltage sense circuit comprises quad op amp U5B and its associated circuits which operate with a gain of 1.1. A low-pass filter formed by quad op amp U5C and its associated circuit removes the noise.

U5A operates as a battery overvoltage indication circuit. The BAT_overvoltage signal is used to cut-off the PWM if battery overvoltage level is reached. The op amps U6A and U6B with their associated circuits perform battery current sensing.

A 2-stage amplifier is used to enhance the signal. The 1st stage operates with a gain of 5 and the 2nd stage operates with a gain of 10. Op amp U6C is a low-pass filter for removing the signal noise.

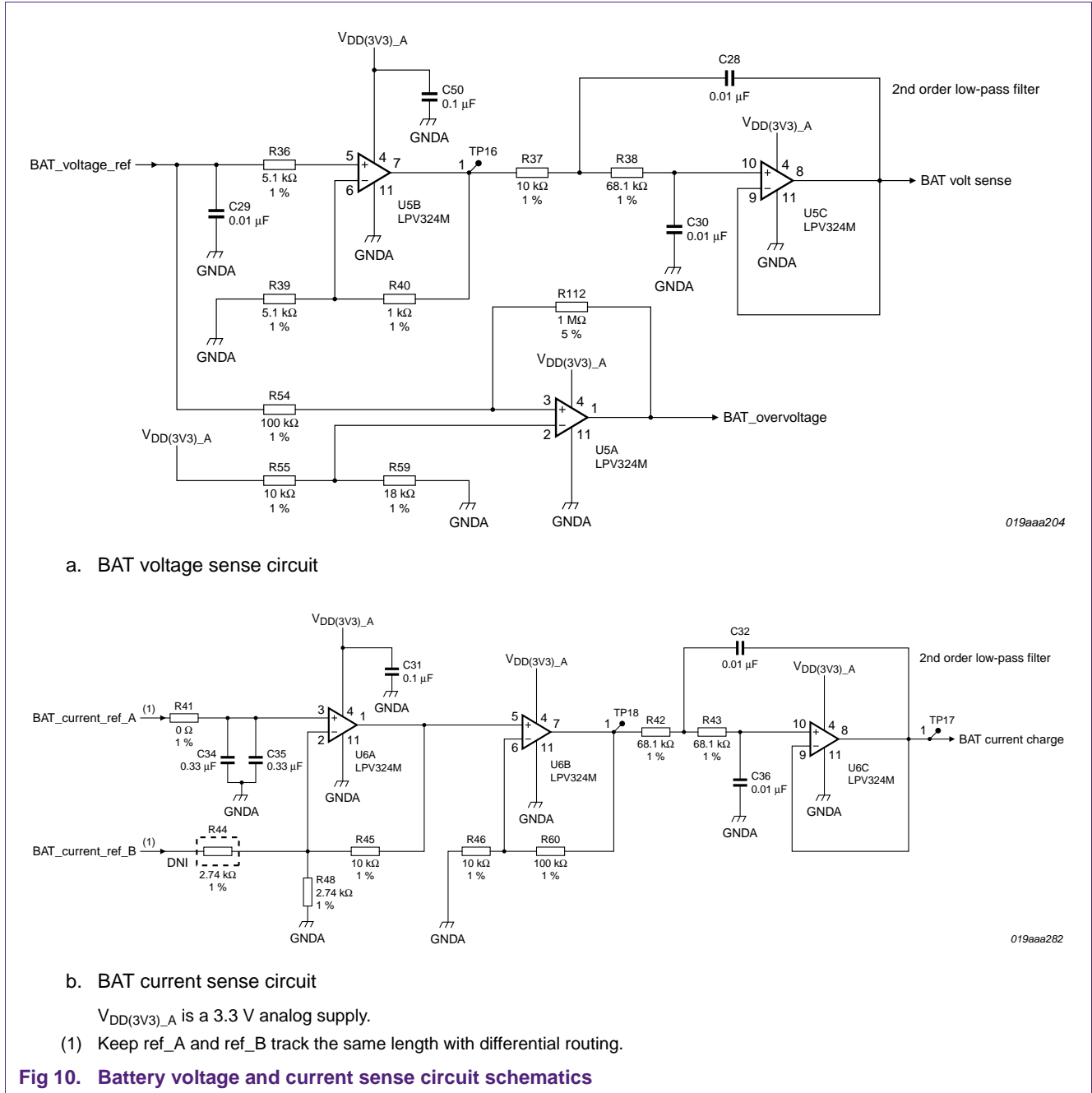

5.2.3 DC-DC buck-boost converter power electronics circuit

The DC-DC buck-boost converter power electronics circuit is shown in [Figure 11](#). The buck-boost converter can operate in buck-boost mode or buck-only mode. It comprises MOSFETs (Q1, Q3, Q4), Schottky rectifier D2 and inductor L1.

When the system is in boost mode, MOSFET Q3 is closed and MOSFET Q4 is open. In buck mode, Q4 is closed and Q3 is open. Capacitors C4 and C7 filter the output. Input bulk capacitors C3 and C5 store energy when switching MOSFET Q1 is off.

Diode D13 protects the circuit if the PV terminals are connected incorrectly. Diode D5 and fuse F1 protect the circuit if battery terminals are connected incorrectly. MOSFET Q2 controls the load. Load-side short-circuit protection is provided by the fuse F2. The high-side gate driver circuit U3 drives the main switching MOSFET.

Low-ohmic current sense resistors R6, R8 and R10 are used for current measurement. Resistor network R3 and R5 sense the PV voltage. Resistor network R4 and R7 sense the battery voltage.

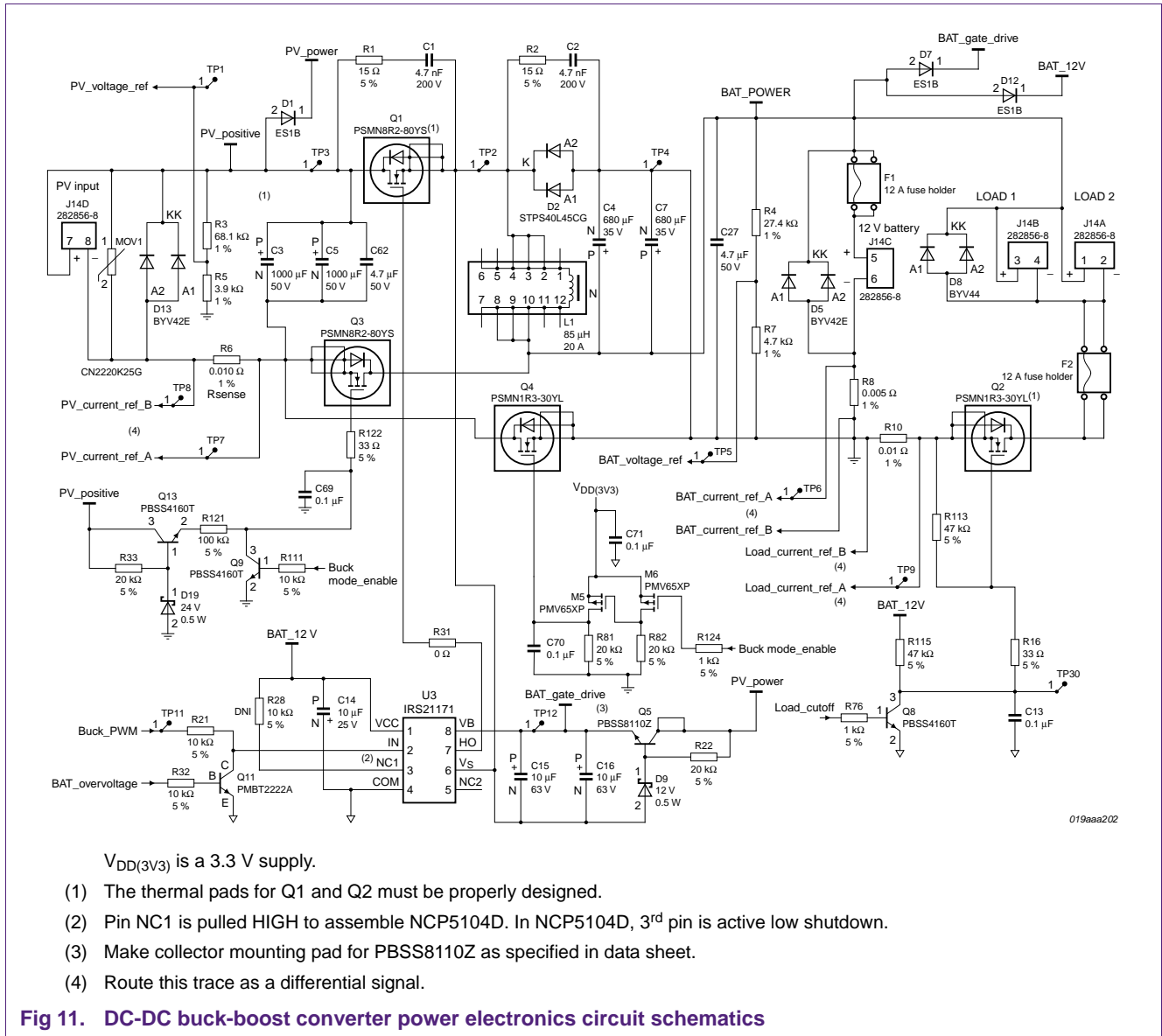

5.2.4 MPT612 digital circuit

The MPT612 digital circuit is shown in [Figure 12](#). The MPT612 controller U15 is the heart of the charge controller board. LEDs D16, D17 and D18 indicate the charge controller's status. NTC1 measures the ambient temperature. The clock circuit is formed by crystal X1 and capacitors (C42, C43). The reset circuitry is formed by resistor R72, capacitor C41 and switching diode D10. J6 is the UART and JTAG debug connector.

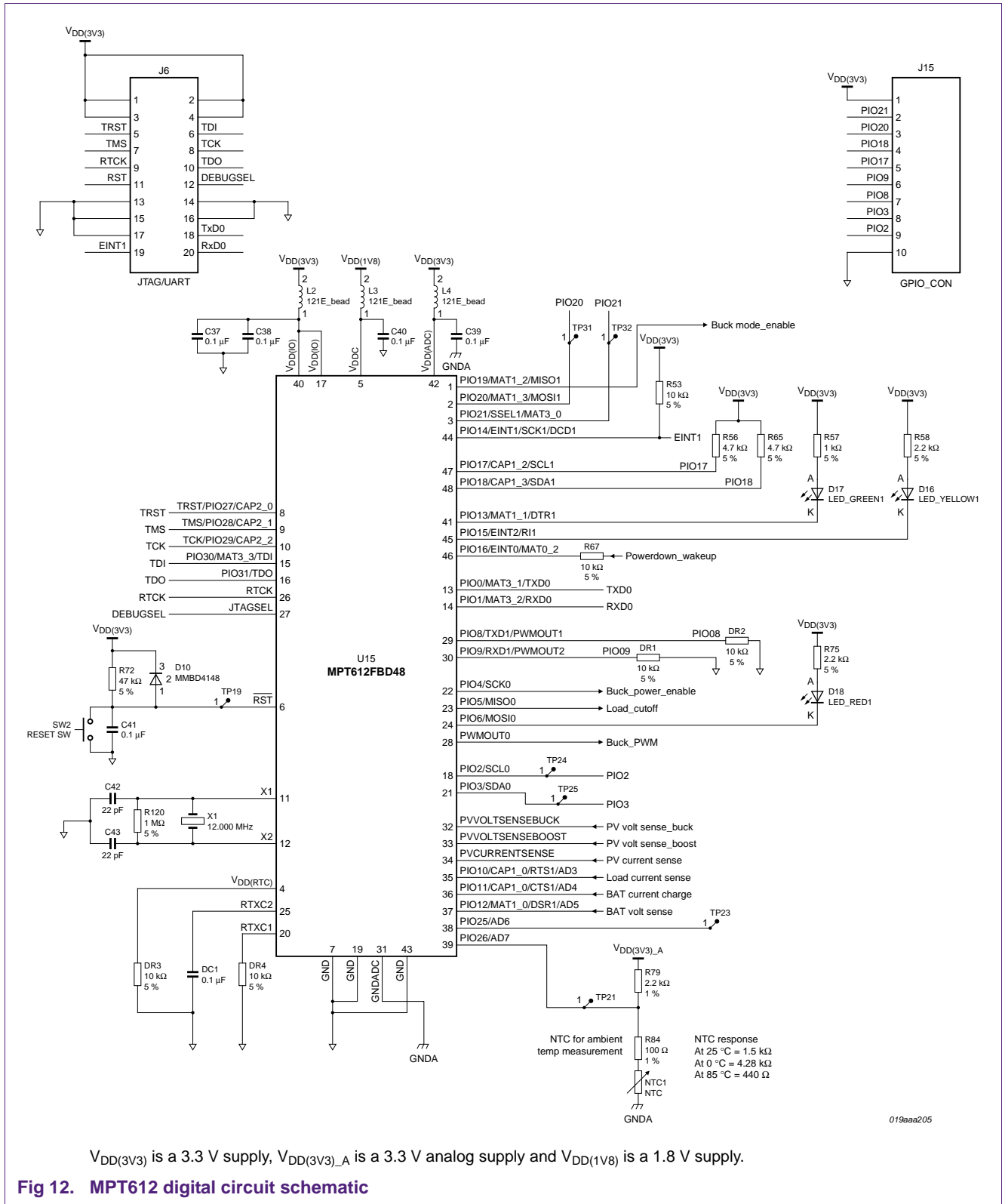
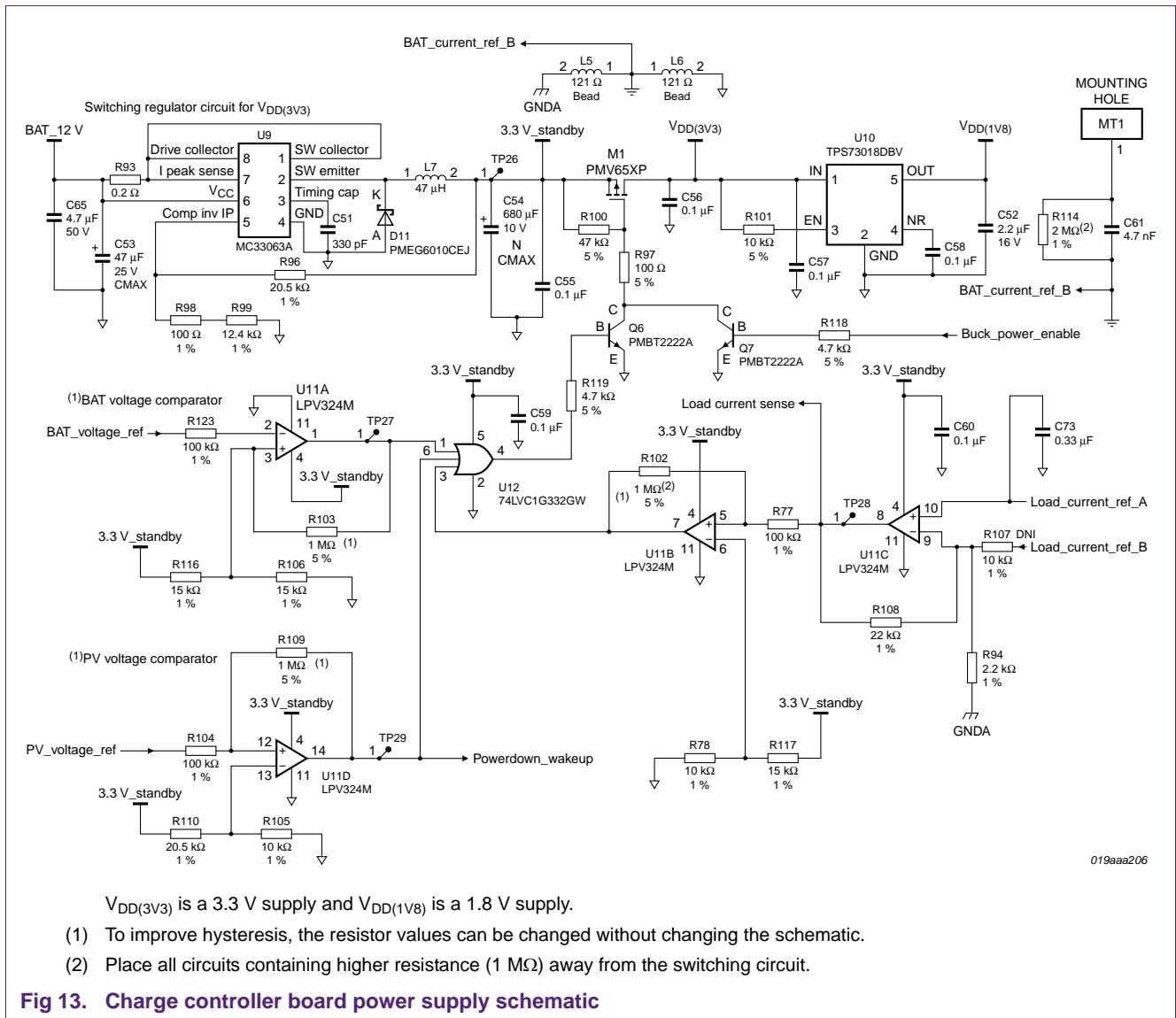

Fig 12. MPT612 digital circuit schematic

5.2.5 Charge controller board power supply circuit

The board power supply circuit is shown in Figure 13. The switching regulator U9 takes battery voltage as the input for a 3.3 V ($V_{DD(3V3)}$) regulated output supply. This 3.3 V supply is used for powering the MPT612 IC and rest of the circuitry. The low dropout regulator U10 is the core voltage for MPT612.

MOSFET switch M1 is used to switch off the power to the board during the standby condition. The battery voltage comparator U11A, PV voltage comparator U11D and overload comparator U11B with OR gate U12 forms the standby control circuit. The Output of PV voltage comparator signal is also used as interrupt signal to the MPT612 to wake it from the power-down state.



5.2.6 JTAG/UART add-on board circuit diagram

The optional JTAG/UART add-on board circuit is shown in Figure 14. This board is an add-on board which is used with the charge controller board for programming. U13 is the RS232-level connector IC. The UART port with additional level-shifted RST and EINT signals is used for ISP programming.

The JTAG connector J7 is used with the debugger. Jumper J9 is closed when JTAG is selected. Jumper J13 and J11 are used to select the ISP programming.

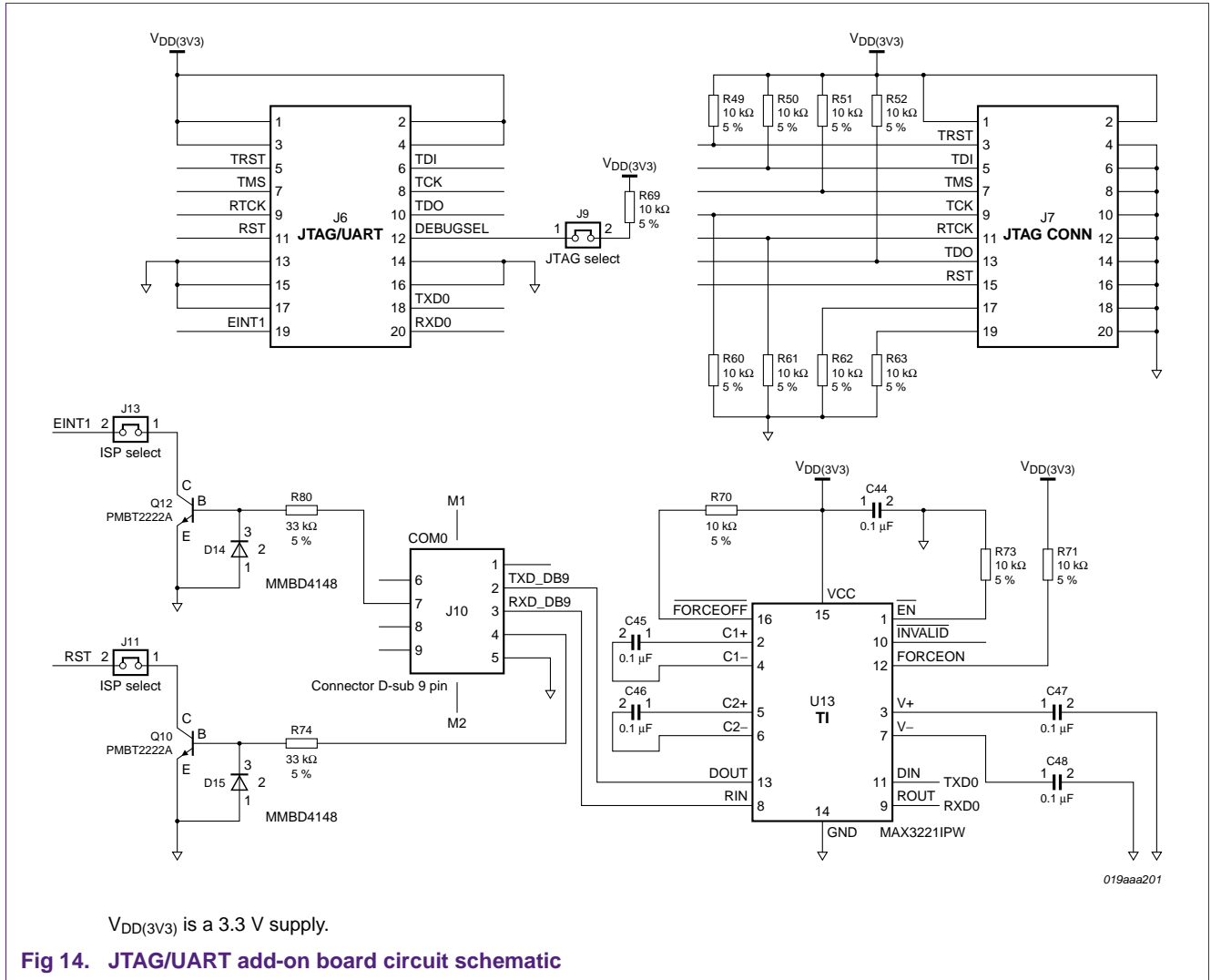

6. Charge controller reference system bill of materials

The charge controller reference system comprises two boards; the charge controller board and the JTAG/UART add-on board. The BOM for each board is described in [Table 3](#) and [Table 4](#).

6.1 Charge controller board Bill Of Materials (BOM)

The charge controller board BOM is given in [Table 3](#).

Table 3. Charge controller board BOM

Component	Description	Manufacturer's part number	Manufacturer
C1, C2	4700 pF, 200 V, ceramic capacitor X7R 0805	ECJ-2VB2D472K	Panasonic Corp.
C3, C5	1000 μ F, 50 V, electrolytic capacitor, low ESR	UHD1H102MHD	Nichicon Corp.
C4, C7	680 μ F, 35 V electrolytic capacitor KY RAD	EKY-350ELL681MK20S	United Chemi-Con Inc.
C1, C13, C21, C24, C31, C37, C38, C39, C40, C41, C49, C50, C55, C56, C57, C58, C59, C60, C69, C70, C71	0.1 μ F, 50 V, ceramic capacitor	08055C104MAT2A	AVX Corp.
C14	10 μ F, 25 V, electrolytic capacitor	UVZ1E100MDD	Nichicon Corp.
C15, C16	10 μ F, 63 V, electrolytic capacitor	UVZ1J100MDD	Nichicon Corp.
C18, C20, C22, C23, C25, C26, C28, C29, C30, C32, C36, C68	0.01 μ F, 50 V, ceramic capacitor	08055C103MAT2A	AVX Corp.
C19	10 μ F, 16 V, electrolytic capacitor, general	UVZ1C100MDD	Nichicon Corp.
C27, C62, C65	4.7 μ F, 50 V, ceramic capacitor, X5R, 1206	C1206C475K5PACTU	Kemet Corp.
C34, C35, C73	0.33 μ F, 50 V, ceramic capacitor	08055C334MAT2A	AVX Corp.
C42, C43	22 pF, 50 V, ceramic capacitor	08055A220KAT2P	AVX Corp.
C51	330 pF, 50 V, ceramic capacitor	08055C331KAT2A	AVX Corp.
C52	2.2 μ F, 16 V, ceramic capacitor	08055C104MAT2A	AVX Corp.
C53	47 μ F, 25 V, electrolytic capacitor	UVZ1E470MDD	Nichicon Corp.
C54	680 μ F, 10 V, electrolytic capacitor	EEUFM1A681L	Panasonic Corp.
C61	4700 pF, 1000 V, ceramic capacitor, X7R 1206	C1206C472KDRACTU	Kemet Corp.
DR1, DR2, DR3, DR4, R21, R28, R32, R53, R67, R101, R111	10 k Ω , 5 %, 1/8 W, 0805 SMD resistor	MCR10EZJH103	ROHM Co. Ltd
D1, D7, D12	fast recovery SMD diode	ES1B	Fairchild Semiconductor
D2	Schottky rectifier, 2 \times 20 A, D2PAK	STPS40L45CG	STMicroelectronics
D5, D13	30 A, 100 V, ultra-fast diode, TO220	BYV42E-150	NXP Semiconductors
D8	30 A, 100 V ultra-fast diode, TO220	BYV44-500	NXP Semiconductors
D9	12 V, 0.5 W, SMD Zener diode	BZT52H-C12	NXP Semiconductors
D10	high speed switching diode, SOT23	MMBD4148	NXP Semiconductors

Table 3. Charge controller board BOM ...continued

Component	Description	Manufacturer's part number	Manufacturer
D11	Schottky rectifier 60 V, 1 A, SOD323F	PMEG6010CEJ	NXP Semiconductors
D16	3 mm through hole; yellow LED	HLMP-1719	Avago Technologies
D17	3 mm through hole; green LED	HLMP-1790	Avago Technologies
D18	3 mm through hole; red LED	HLMP-K150	Avago Technologies
D19	24 V, 0.5 W, SMD Zener diode	BZT52H-C24	NXP Semiconductors
F1, F2	12 A high current fuse holder clips	751.0056	Schurter Group
J6	10-way, dual row 2.54 mm pitch connector	SSW-110-01-T-D	Samtec
J14	8-pin, side entry 5 mm, 300 V, 24 A terminal block	282856-8	Tyco Electronics
J15	10-way single row, 2.54 mm pitch connector	TSW-110-07-T-S	Samtec
L1	85 μ H, 25 A inductor	-	EPCOS AG
L2, L3, L4, L5, L6, L8	120 Ω , 100 MHz, 500 mA; ferrite bead	EXC-3BP121H	Panasonic Corp.
L7	47 μ H, 1.5 A SMD shielded inductor	B82464G4473M	EPCOS AG
MOV1	SMD MOV for surge protection	SIOV-CN2220K25G	EPCOS AG
M1, M5, M6	P-channel MOSFET	PMV65XP	NXP Semiconductors
NTC1	1.5 k Ω at 25 $^{\circ}$ C (radial) leaded NTC	2381 640 63152	Vishay Electronic
Q1, Q3	N-channel Trench MOSFET	PSMN8R2-80YS	NXP Semiconductors
Q2, Q4	N-channel Trench MOSFET	PSMN1R3-30YL	NXP Semiconductors
Q5	NPN transistor 1 A	PBSS8110Z	NXP Semiconductors
Q6, Q7, Q11	NPN transistor, SW 600 mA, 40 V, SOT23	PMBT2222A	NXP Semiconductors
Q8, Q9, Q13	NPN transistor, 1 A, 60 V SOT23	PBSS4160T	NXP Semiconductors
R1, R2	15 Ω , 5 %, $\frac{1}{4}$ W, 0805 SMD resistor	ESR10EZPJ150	ROHM Co. Ltd
R3, R25, R29, R30, R38, R42	68.1 k Ω , 1 %, $\frac{1}{8}$ W, 0805 SMD resistor	MCR10EZHF6812	ROHM Co. Ltd
R4	27.4 k Ω , 1 %, $\frac{1}{8}$ W, 0805 SMD resistor	MCR10EZHF2742	Yageo Corp.
R5	3.9 k Ω , 1 %, $\frac{1}{8}$ W, 0805 SMD resistor	MCR10EZHF3901	Yageo Corp.
R6, R10	0.010 Ω , 1 %, 2 W, resistor, current sense	MCS3264R010FER	Ohmite Mfg. Co.
R7	4.7 k Ω , 1 %, $\frac{1}{8}$ W, 0805 SMD resistor	MCR10EZHF4701	Yageo Corp.
R8	0.005 Ω , 1 %, 2 W, resistor, current sense	MCS3264R005FER	Ohmite Mfg. Co.
R22, R33, R81, R82	20 k Ω , 5 %, $\frac{1}{8}$ W, 0805 SMD resistor	MCR10EZHJ203	ROHM Co. Ltd
R23, R24, R26, R35, R37, R45, R46, R55, R64, R66, R78, R105, R107	10 k Ω , 1 %, $\frac{1}{8}$ W, 0805 SMD resistor	MCR10EZPF1002	ROHM Co. Ltd
R27, R40	1 k Ω , 1 %, $\frac{1}{8}$ W, 0805 SMD resistor	MCR10EZHF1001	ROHM Co. Ltd
R31, R41	0 Ω , $\frac{1}{8}$ W, 0805 SMD resistor	MCR10EZHJ000	ROHM Co. Ltd
R36, R39	5.1 k Ω , 1 %, $\frac{1}{8}$ W, 0805 SMD resistor	MCR10EZHF5101	ROHM Co. Ltd
R44, R48	2.74 k Ω , 1 %, $\frac{1}{8}$ W, 0805 SMD resistor	MCR10EZPF2741	ROHM Co. Ltd
R54, R60, R77, R104, R123	100 k Ω , 1 %, $\frac{1}{8}$ W, 0805 SMD resistor	MCR10EZPF1003	ROHM Co. Ltd
R56, R65, R118, R119	4.7 k Ω , 5 %, $\frac{1}{8}$ W, 0805 SMD resistor	MCR10EZHJ472	ROHM Co. Ltd
R57, R76, R124	1 k Ω , 5 %, $\frac{1}{8}$ W, 0805 SMD resistor	MCR10EZHJ102	ROHM Co. Ltd

Table 3. Charge controller board BOM ...continued

Component	Description	Manufacturer's part number	Manufacturer
R58, R75	2.2 k Ω , 5 %, 1/8 W, 0805 SMD resistor	MCR10EZPJ222	ROHM Co. Ltd
R59	18.0 k Ω , 1 %, 1/8 W, 0805 SMD resistor	MCR10EZPF1802	ROHM Co. Ltd
R72, R100, R113, R115	47 k Ω , 5 %, 1/8 W, 0805 SMD resistor	MCR10EZPJ473	ROHM Co. Ltd
R79, R94	2.2 k Ω , 1 %, 1/8 W, 0805 SMD resistor	MCR10EZPF2201	ROHM Co. Ltd
R84, R86, R87, R98	100 Ω , 1 %, 1/8 W, 0805 SMD resistor	MCR10EZHF1000	ROHM Co. Ltd
R93	0.2 Ω , 1 %, 1/4 W, 0805 SMD resistor	MCR10EZHF200	ROHM Co. Ltd
R96, R110	20.5 k Ω , 1 %, 1/8 W, 0805 SMD resistor	MCR10EZHF2052	ROHM Co. Ltd
R97	100 Ω , 5 %, 1/8 W, 0805 SMD resistor	MCR10EZPJ101	ROHM Co. Ltd
R99	12.4 k Ω , 1 %, 1/8 W, 0805 SMD resistor	MCR10EZHF1242	ROHM Co. Ltd
R102, R103, R109, R112, R120	1.0 M Ω , 5 %, 1/8 W, 0805 SMD resistor	MCR10EZPJ105	ROHM Co. Ltd
R106, R116, R117	15 k Ω , 1 %, 1/8 W, 0805 SMD resistor	MCR10EZHF1502	ROHM Co. Ltd
R108	22 k Ω , 1 % SMD resistor	MCR10EZHF2202	ROHM Co. Ltd
R114	2.0 M Ω , 1%, 1/4 W, 1206 SMD resistor	MCR18EZPF2004	ROHM Co. Ltd
R121	100 k Ω , 5 %, 1/8 W, 0805 SMD resistor	MCR10EZHJ104	ROHM Co. Ltd
R122, R16	33 Ω , 5 %, 1/8 W, 0805 SMD resistor	RMCF 1/10 33 5 % R	Stackpole Electronics Inc.
SW2	switch TACT RA H = 1.24 mm, 160 GF	FSMRA2J	Tyco Corp.
U3	single channel high-side gate driver	IRS21171STRPBF	International Rectifier
U4, U5, U6, U11	quad, low voltage rail-to-rail op amp	LPV324M	National Semiconductor
U9	1.5 A, step-down switching regulator	MC33063ADR2G	On Semiconductor
U10	1.8 V, 200 mA, LDO	TPS73018DBV	Texas Instruments
U12	single 3 input OR gate	74LVC1G332GW	NXP Semiconductors
U14	IC current monitor 3 %, SOT23-5	INA194AIDBVT	Texas Instruments
U15	MPPT IC	MPT612FBD48	NXP Semiconductors
X1	12 MHz, crystal, fundamental frequency	ECS-120-20-4XDN	ECS Inc.
F1	12 A, fast blow fuse, battery reverse protection	PSF-12A	Protectron
F2	10 A, fast blow fuse, battery reverse protection	PSF-10A	Protectron
PCB	PCB, DS, 150 mm \times 100 mm	PCB	-

6.2 JTAG/UART add-on board Bill Of Materials (BOM)

The JTAG/UART add-on board BOM is given in [Table 4](#).

Table 4. JTAG/UART add-on board BOM

Component	Description	Manufacturer's part number	Manufacturer
C44, C45, C46, C47, C48	0.1 μ F, 50 V, ceramic capacitor	08055C104MAT2A	AVX Corp.
D14, D15	high-speed switching diode, SOT23	MMBD4148	NXP Semiconductors
J6	10-way, dual row 2.54 mm pitch berg connector (20 pin)	TSS-110-01-L-D	Samtec
J7	10-way, dual row 2.54 mm pitch berg connector (20 pin)	TSW-110-07-T-D	Samtec
J9	2 pin, 2.54 mm jumper for JTAG selection	22032021	Molex Inc.
J10	D-sub connector 9 pin female vertical	171-009-213R001	Norcomp Inc.
J11, J13	2 pin, 2.54 mm, jumper for ISP selection	22032021	Molex Inc.
Q10, Q12	NPN SW 600 mA, 40 V transistor SOT23	PMBT2222A	NXP Semiconductors
R49, R50, R51, R52, R60, R61, R62, R63, R69, R70, R71, R73	10 k Ω , 5 %, $\frac{1}{8}$ W, 0805 SMD resistor	MCR10EZHZ103	ROHM Co. Ltd
R74, R80	33 k Ω , 5 %, $\frac{1}{8}$ W, 0805 SMD resistor	RC0805JR-0733KL	ROHM Co. Ltd
U13	driver/receiver RS-232 1-CH 16TSSOP	MAX3221CPWR	Texas Instruments
PCB	PCB, DS, 75 mm \times 40 mm	-	-

7. Component selection

7.1 PV System parameters

The following parameters must be considered for the major components in the design of the MPPT charge controller reference system:

- PV panel rating: 100 W at STC
- PV voltage range: up to 27 V
- MPP voltage range: 10 V to 21 V
- Maximum input current: 6 A
- Resistance across the panel cables: 400 m Ω
- MPP voltage on board terminals: 7.5 V to 18.5 V (after 2.5 V maximum drop across the cable)

7.2 Major components

The major MPPT charge controller reference system components are listed below:

- Frequency of DC-DC converter operation; see [Section 7.2.1](#)
- Inductor; see [Section 7.2.2](#)
- Input bulk capacitor; see [Section 7.2.3](#)
- Switching MOSFET; see [Section 7.2.4](#)

- Output diode; see [Section 7.2.5](#)
- Output capacitor; see [Section 7.2.6](#)
- Thermal pads; see [Section 7.2.7](#)

7.2.1 Frequency of DC-DC converter operation

The optimum frequency for DC-DC converter operation was arrived at after keeping in mind the trade-off between switching losses, inductor size and inductor losses. The higher the switching frequency, the smaller the inductor size. However, the switching loss in the switching device and core loss in the inductor are directly proportional to the operating frequency. In this design, the converter switching frequency is fixed at 20 kHz based on the experimental results which ensures both switching loss and inductor size are optimized.

7.2.2 Inductor

- $I_{L(AV)} = I_O / (1 - \delta)$

Where I_O is the output current and δ is the duty cycle. In buck-boost mode, the maximum duty cycle is 60 %.

- $I_{L(AV)} = 6 / 0.4 = 15 \text{ A}$
- $I_{L(pk)} = (I_O / 1 - \delta) + \Delta I_L / 2 = 18.75 \text{ A}$; where ΔI_L is the inductor ripple current
- $V_I = 19 \text{ V}$
- $\delta = 0.8 \%$
- $\Delta I_L = 0.3 * I_{L(AV)}$
- $f_{osc} = 20 \text{ kHz}$
- $L_{min} = V_I \times \delta / (f_{osc} \times \Delta I_L) = 76 \mu\text{H}$

The inductor selected for proto stage is ~85 $\mu\text{H}/20 \text{ A}$. Also refer to:

- www.coilcraft.com/apps/selector/selector_1.cfm
- schmidt-walter.eit.h-da.de/smeps_e/ivw_smeps_e.html

7.2.3 Input bulk capacitor

The input capacitor is mainly selected on its ESR value and on the RMS current rating to support the high current changes on the input. Low ESR capacitors are recommended to minimize the input voltage ripple and interference with other circuits in the system.

- $C_{I(min)} = (I_I * t_{on}) / \Delta V_I$
- $I_I = 6 \text{ A}$
- $t_{on} = 25 \mu\text{S} (50 \% \delta)$
- input ripple voltage (ΔV_I) = 0.2 V
- $C_{I(min)} = (6 * 25) / 0.2 = 750 \mu\text{F}$
- $\text{ESR} = \Delta V_I / (I_I / \delta) = 0.2 / (6 / 0.5) = 16 \text{ m}\Omega$

To reduce the ESR, two 1000 μF , 50 V capacitors are used in parallel. Nichicon part number UHD1H102MHD with ESR 21 $\text{m}\Omega$, rated ripple current 3.01 A.

7.2.4 Switching MOSFET

- Peak current in the MOSFET $I_{SW(pk)} = I_{L(pk)} = 18 \text{ A}$
- V_I at some cases can go up to 21 V
- $V_{DS(max)} = V_I + V_O = 21 \text{ V} + 16 \text{ V} = 37 \text{ V}$
- Select a MOSFET with a V_{DS} greater than 37 V and I_{DS} greater than 15 A.

The MOSFET selected is NXP part number PSMN8R2-80YS: 82 A $I_{DS(max)}$, 8.2 m Ω $R_{DS(on)}$, 80 V (V_{DS}), Loss Free PACKage (LFPACK) SMD MOSFET.

7.2.5 Output diode

- $I_{D(AV)} \geq I_o = 6 \text{ A}$
- $I_{D(pk)} = I_{L(pk)} = 18 \text{ A}$
- $V_{RRM} \geq V_I + V_O = 37 \text{ V}$

The efficiency of the converter depends on the diode V_F (in buck-boost operation), so a diode with a low V_F should be selected.

The Schottky diode selected is STPS40L45CG:

- 45 V, 40 A
- $V_F = 0.45 \text{ V}$

7.2.6 Output capacitor

$$C_O \geq \frac{I_{O(max)} \times ((V_O + V_F) \div ((V_{I(min)} - V_{sw}) + (V_O + V_F)))}{f_{osc} \times \Delta V_{OC}} \quad (1)$$

- $I_{O(max)} = 6 \text{ A}$
- $V_O = 16 \text{ V}$
- $V_F = 0.45 \text{ V}$
- $V_{I(min)} = 8 \text{ V}$
- $V_{sw} = 0.4 \text{ V}$
- $f_{osc} = 20 \text{ kHz}$
- $\Delta V_{OC} = 200 \text{ mV}$
- $C_O \geq 1028 \text{ }\mu\text{F}$
- $ESR = \Delta V_O / I_{sw(peak)} = 11.1 \text{ m}\Omega$

Select two output electrolytic capacitors of 680 μF , 35 V with an ESR of less than 25 m Ω . Place them in parallel so that effective ESR is less than 11.5 m Ω .

The selected component is a Nichicon UHD1V680MHD.

- ESR 21 m Ω
- Rated ripple current is 2.36 mA

7.2.7 Thermal pads

Maximum junction temperature ($T_{j(max)}$) = $P_{AV} \times R_{th(tot)} + T_{amb}$

Where P_{AV} = average power; $R_{th(tot)}$ = total thermal resistance and T_{amb} = ambient temperature.

The thermal resistance of the PCB in FR4 material (2 oz. copper) is 90 °C/W for 1 cm². However, more thermal pads are required to minimize the MOSFET junction temperature. One option is to add copper to be on the safer side. The PCB R_{th} is considered to be 300 °C/W with 70 micron for calculation purposes. The maximum device junction temperature is limited to 100 °C. The ambient temperature is considered to be 50 °C.

7.2.7.1 Thermal pad for D2PAK diode

- Power dissipation at 2.88 W maximum (0.48 V V_F and 6 A average current)
- Minimum pad area required: 31 mm × 31 mm on both sides
- $R_{th(j-a)} = 30$ °C/W
- Temperature increase = power dissipated × $R_{th(j-a)}$
- Temperature increase = 2.88 W × 30 °C = 86 °C

The above $R_{th(j-a)}$ is based on a copper thickness of 35 micron. However, with a 75 micron thickness of copper, the $R_{th(j-a)}$ is further reduced. PCB thermal pad copper area is calculated using [Equation 2](#):

$$Area = \frac{P_d \times R_{th(pcb-a)}}{(T_j - T_{amb} - P_d \times (R_{th(j-c)} + R_{th(c-pcb)}))} \quad (2)$$

- P_d = power dissipated in the device in W
- $R_{th(pcb-a)}$ = thermal resistance of a 1 cm² PCB surface to ambient in °C/W
- T_j = maximum or desired junction temperature in °C
- T_{amb} = ambient temperature in °C
- $R_{th(j-c)}$ = thermal resistance from junction to case in °C/W
- $R_{th(c-pcb)}$ = thermal resistance from case to PCB surface in °C/W

[Equation 2](#) calculates the total PCB copper area needed to keep the junction temperature within the defined limits. The thermal pad area required for a single-sided PCB is calculated. If both sides of the PCB are used as a thermal pad then this value is divided by 2. If thermal vias are not used, it is assumed that the heat is mainly dissipated on one side of the board. However, the area on both sides of the PCB can be counted when adequate thermal vias are used.

7.2.7.2 MOSFET thermal pad calculation

The minimum thermal pad area required for MOSFETs is as follows:

Q1; part number: PSMN8R2-80YS

- $R_{DS(on)}$ at 100 °C is 13.8 m Ω , current = 6 A
- Power: 1.5 W
- Pad area required: 25 mm \times 25 mm on both sides
- Make an additional pouring because this is the switching device

Q2; part number: PSMN1R3-30YL

- $R_{DS(on)}$ at 100 °C is 2.5 m Ω , current = 10 A
- Power: 250 mW
- Pad area required: 10 mm \times 10 mm on both sides

Q3; part number: PSMN8R2-80YS

- $R_{DS(on)}$ at 100 °C is 13.8 m Ω , current = 6 A
- Power: 500 mW
- Pad area required: 13 mm \times 13 mm on both sides

Q4; part number: PSMN1R3-30YL

- $R_{DS(on)}$ at 100 °C is 2.5 m Ω , current = 6 A
- Power: 200 mW (maximum)
- Pad area required: 8 mm \times 8 mm on both sides

Refer to [Equation 2](#) for the calculation of the pad area and *AN10874 LFPK MOSFET thermal design guide* for detailed information on specifying PCB materials.

8. System test plan

This section describes the tests which are performed to demonstrate that the MPPT charge controller reference system meets the specifications provided in [Table 2 on page 9](#).

- Test cases are decided based on requirements for demonstration to be completed in 10 hours
- When possible and acceptable, to speed up the testing, DC power supplies can replace PV panel and battery
- Load means electronic DC-load
- Destructive tests (marked as D in the test title) are performed at the end of the test cycle (as required)
- Test set-up combination abbreviations are described in [Table 5](#).

Table 5. Test set-up abbreviations

Name	Description
S	DC-supply
P	PV panel
N	NXP charge controller
B	battery with a maximum charge of 20 Ah to charge the battery in the short time available
E	Electronic DC-load

- Infrastructure required

Table 6. Infrastructure requirements

Description	Limits
DC supply	20 V and 6 A maximum
DC supply maximum	20 V and 20 A maximum
Electronic DC-load (non-inductive)	up to 20 A and 20 V
PV panel with cables to charge controller under test	70 W or 80 W
Pre-charged 12 V lead-acid battery	20 Ah maximum
4-channel data logger	two for voltages up to 20 V and two for currents up to 20 A
Current meter	1 A with 1 mA accuracy minimum; 0 A to 20 A
Oscilloscope	to measure 500 ms time duration
PC/laptop with MS-Excel and other general purpose software packages	-

Table 7. System tests overview

See [Table 5](#) for the test set-up abbreviation definitions.

Test	Test description	Set-up	Expected result and behavior	Time (± min)
Functional				
Boost and buck charging	connect variable DC supply to PV terminal and battery at 14 V to the charge controller. Increase input voltage from 11 V to 19 V in steps of 2 V. Measure input and output voltages and currents.	SNB	boost mode: when the input voltage is less than the battery voltage, charging current flows to the battery buck mode: when the input voltage is less than the battery voltage, charging current flows in to the battery	10
Standby current	connect charge controller to the battery without PV or load and measure battery discharge current flowing into charge controller.	NB	should be below 10 mA	10
MPP peak latching	connect PV panel output to charge controller and battery at 12 V to the battery terminals. Measure input and output voltages and currents through data logger for 15 minutes minimum. Plot input power (Watts) as a function of time.	PNB	the PV panel power should continue to latch to the panel's MPP under the given environmental conditions.	30
MPP tracking with shadowing	repeat the above test with partial shadowing of the panel ($\frac{1}{5}$ th to $\frac{1}{4}$ th)	PNB	the PV panel power should continue to latch to the panel's MPP under the given environmental conditions.	30
Charging cycle implementation	connect DC power supply at 17 V and 5 A, and pre-charged 20 Ah lead-acid battery just below boost charge on voltage (12.4 V) to charge controller. Charge battery at 4 A CC until float stage (fully charged) and track battery V and I. Plot charging cycle to verify the charging cycle control algorithm functionality. Observe the battery indicator light status.	SNB	battery charge cycle should be: CC mode: boost starts at 12.6 V and ends at 15.3 V. CV mode: float V = 13.6 V, battery light indication should be: green blinking: while charging green on: battery is fully charged and input supply present	120
Battery status indication	connect a DC supply with reverse current blocking diode and minimal load (to arrest any overshoot of inductor voltage) at battery terminal of the charge controller. Connect load to the load terminal. Increase voltage from 10.8 V to 16 V and observe the battery light status		battery light indication should be: green blinking: while charging green on: when battery is fully charged yellow blinking: when battery is Low (just above 10.8 V) red: when battery voltage reaches 10.8 V and load is cut-off	10
Load status indication	connect battery and electronic DC load to charge controller. Increase load current from 0 A to 15 A and observe load indication lights.	NBE	no indication until the load current is within 12.5 A and red above 12.5 A and load is cut-off	20

Table 7. System tests overview

See [Table 5](#) for the test set-up abbreviation definitions.

Test	Test description	Set-up	Expected result and behavior	Time (± min)
Protection				
PV reverse current flow prevention	connect a DC voltage of 12 V to battery terminals on the charge controller with no load at the load terminals. Connect electronic DC load at PV terminals. Decrease load from maximum to minimum to simulate PV acting as load to battery. Observe current flow to the DC load.	SNBE	no current should flow into the load	20
Battery low load disconnection when PV is not present (MCU in standby)	connect DC load to the charge controller and DC supply of 12 V to battery terminals. Decrease DC supply voltage to below 10.8 V slowly. Observe load status.	NBE	the load should be disconnected and load light should turn red when battery voltage is at 10.8 V	10
Battery low load reconnection when PV is not present (MCU in standby)	connect DC load to the charge controller and DC supply to battery terminals. Increase supply from 12 V to 12.5 V slowly. Observe load status.	SNBE	the load should be reconnected and load light should change from red to off state at 12.2 V	5
Battery low load disconnection when PV is present (MCU active)	connect DC load to the charge controller and DC supply of 12 V to battery terminals. Decrease DC supply voltage to below 10.8 V slowly. Observe load status.	NBE	the load should be disconnected and the load light should turn red when battery voltage is at 10.8 V	5
Battery low load reconnection when PV is present (MCU active)	connect DC load to the charge controller and DC supply to battery terminals. Increase supply from 12 V to 12.5 V slowly. Observe load status.	NBE	the load should be reconnected and load light should change from red to off-state at 12.2 V	5
Load cut-off due to overload	connect battery and electronic DC load to charge controller and increase load current to 8 A slowly. Connect oscilloscope and observe load current and voltage.	NBE	after 500 ms, the load should be disconnected and the load light should turn red	10
Efficiency				
Converter efficiency in buck-boost mode	connect DC supply and DC load to the charge controller. Vary the input voltage between 12 V and 20 V in such a way to set input power at 5 W intervals from 30 W to 80 W and note down output voltage and current. Calculate efficiency (output wattage/input wattage). Plot efficiency as a function of input wattage. Remark: This test can be run only if the debug option is selected during the initial setup.	SNE	efficiency should be between 92 % minimum and 94 % maximum over the input range	60

Table 7. System tests overview

See [Table 5](#) for the test set-up abbreviation definitions.

Test	Test description	Set-up	Expected result and behavior	Time (± min)
Converter efficiency in buck mode	DC supply and DC load to the charge controller. Make the system operate in buck mode only through software. Vary the input voltage between 12 V and 20 V in such a way to set input power at 5 W intervals from 0 W to 80 W and note down output voltage and current. Calculate efficiency (output wattage/input wattage). Efficiency as a function of input wattage. Remark: This test can be run only if the debug option is selected during the initial setup.	SNE	efficiency should be 98 % minimum	10
Destructive				
Battery reverse connection protection (destructive)	connect DC supply at 17 V and 3 A and battery in reverse (battery +ve to charge controller –ve and vice versa) polarity to charge controller.	NBE	battery fuse should blow	10
Load cut-off due to short-circuit (destructive)	connect 13.8 V supply to battery terminals. Short the load terminals and observe load and load side fuse.	NBE	load should be cut-off, fuse should blow and red light should glow	10
	Miscellaneous such as the explanation, Q & A during testing	-	-	60
Total duration				435

9. Benchmarking strategy

The MPPT charge controller reference system was benchmarked against the best charge controllers on the market.

Two identical test set-ups were made

- one for an MPT612-based MPPT charge controller reference design
- the other for the charge controller against which the reference design is benchmarked

Benchmarking was also done for two types of panels:

- $P_{MPP} = 80\text{ W}$, $V_{MPP} = 17\text{ V}$, $I_{MPP} = 4.71\text{ A}$, $I_{sc} = 5.39\text{ A}$ and $V_{OC} = 21.20\text{ V}$ at STC
- $P_{MPP} = 70\text{ W}$, $V_{MPP} = 17\text{ V}$, $I_{MPP} = 4.12\text{ A}$, $I_{sc} = 4.72\text{ A}$ and $V_{OC} = 21.20\text{ V}$ at STC

70 Ah, 12 V, lead-acid battery was used in all the set-ups. A data logger was used for recording PV voltage/current and battery voltage/current.

Benchmarking criteria/parameters were as follows:

- Cumulative ampere hour (Ah) flowing into the battery from the charge controllers under identical environmental and experimental test conditions
- Percentage difference in Ah of the charge controllers

10. System test and benchmarking results

All the system tests mentioned in [Table 7](#) were performed and the expected results obtained.

The benchmarking results were captured and [Figure 15](#) shows the enhanced performance provided by the MPT612-based MPPT charge controller reference board when compared to other charge controllers on the market.

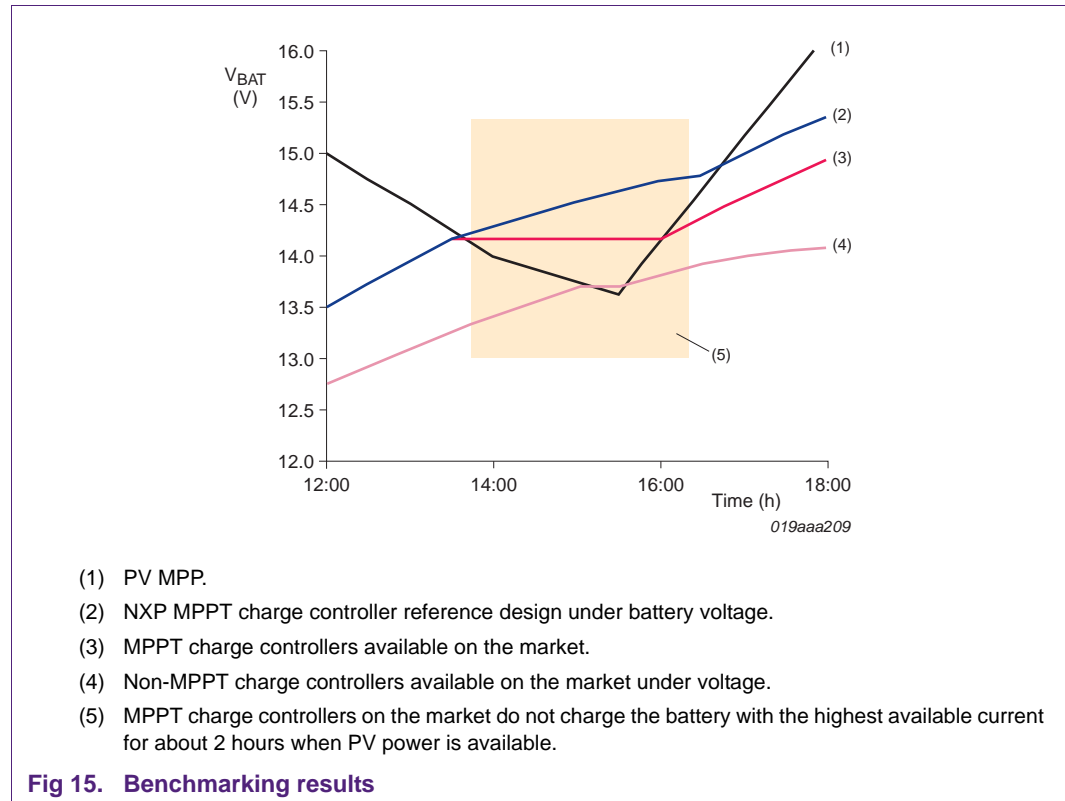

Fig 15. Benchmarking results

11. Steps for evaluating the charge controller reference system

This section describes the steps needed to evaluate the charge controller reference system. The reference system has a sample charge controller application programmed in to the MPT612's flash memory. This sample charge controller application conforms to the parameters set in [Table 2 on page 9](#).

11.1 Testing functionality

The charge controller board can be used to run all the tests in [Table 6 "Infrastructure requirements" on page 31](#) except the open-loop efficiency tests. The set of steps is as follows:

1. Connect the external load terminal to the L1+/L2+ and L1-/L2- terminals of the reference system ensuring correct polarity.

2. Connect 12 V battery terminal to the BAT+ and BAT– terminals of the reference system ensuring correct polarity. The battery should meet the specification described in [Section 4.1 on page 9](#).
3. Connect PV input to the PV+ and PV– terminal of MPT612 reference board. The PV should conform to the specification described in [Section 4.1 on page 9](#).
4. The system function is indicated by the LEDs D16, D17 and D18. [Table 8](#) shows the LED status for different system functions.
5. When the PV terminals are connected, the system starts booting, indicated by the LEDs D16, D17 and D18 (if sufficient PV power is available).
6. Measure PV voltage, PV current, battery voltage and battery current, using a multi-meter. The values will vary depending on the maximum power generated from the PV panel.
7. When sufficient PV power is available, the charge controller tracks the MPP, charges the battery and supplies power to the loads after 10 s.

Table 8. LED status indications

Indication	Value
Green on	battery is charging
Green blinking	battery fully charged
Yellow blinking	battery is low
Red on	battery low, cut-off or overload cut-off
All LEDs off	system is in standby

11.2 Testing open loop efficiency

The JTAG/UART add-on board is needed for the open-loop efficiency tests. The steps are as follows:

1. Connect JTAG/UART add-on board to the charge controller board's J6 port.
2. Connect UART DB9 connector of the COM port of the PC to J10 of the JTAG/UART add-on board.
3. Open a terminal application on the PC (HyperTerminal or TeraTerm) and configure the following settings in that application:
 - a. Baud rate = 38400
 - b. Data bits = 8
 - c. Stop bits = 1
 - d. Flow control = None
 - e. Parity = None
4. Connect the external load terminal to the L1+/L2+ and L1–/L2– terminals of the reference system ensuring the correct polarity.
5. Connect 12 V battery terminal to the BAT+ and BAT– terminals of the reference system ensuring the correct polarity. The battery should meet the specification described in [Section 4.1 on page 9](#).
6. Connect PV input to the PV+ and PV– terminal of MPT612 reference board. The PV should meet the specification described in [Section 4.1 on page 9](#).

7. The application, present in the charge controller board waits for 10 seconds for a key to be pressed on the console:
 - a. When a key is pressed, it displays a menu on the console for the open-loop efficiency tests. The user can see the results on the console.
 - b. When a key is not pressed, the charge controller functionality is executed.
8. The system function is indicated by the LEDs D16, D17 and D18. [Table 8](#) shows the LED status for different system functions.
9. When the PV terminals are connected, the system starts booting, indicated by LEDs D16, D17 and D18 (if there is sufficient PV power is available).
10. Measure the PV voltage, PV current, battery voltage and battery current, using a multi-meter. The values will vary depending on the maximum power generated by the PV panel.
11. When sufficient PV power is available, the output of the sample charge controller application program is displayed on the PC's terminal application (HyperTerminal or TeraTerm).

Remark: The following output is only a sample and can differ from system to system. In addition, the connected PV, battery and load parameters will have an effect on the displayed values.

```

1
2 *****
3 MPT612 Sample Charge controller Application
4 v1.0
5 *****
6
7 SWCONV_BOOST
8 Waiting for minimum power to be present.....
9 Scanning => full
10 Prtrb
11
12 *MPP LATCHED: Vmpp(mV) = 16101
13
14 Prtrb
15
16 *MPP LATCHED: Vmpp(mV) = 15992
17 Prtrb
18
19 *MPP LATCHED: Vmpp(mV) = 15956
20
21 SWCONV_BUCK
22 Prtrb
23
24 *MPP LATCHED: Vmpp(mV) = 16177
25 Prtrb
26
27 *MPP LATCHED: Vmpp(mV) = 16439
28 Prtrb
29
30 *MPP LATCHED: Vmpp(mV) = 16613
    
```

```

31      Prtrb
32
33      *MPP LATCHED: Vmpp(mV) = 16468
34      Prtrb

```

12. Steps to link and test new applications

To learn how easy it is to link and test new applications please refer to the MPT612 SW development kit at www.nxp.com/solar/.

13. Abbreviations

Table 9. Abbreviations

Acronym	Description
ADC	Analog-to-Digital Converter
API	Application Programming Interface
ESR	Equivalent Series Resistance
FIFO	First In, First Out
GPIO	General Purpose Input/Output
I ² C	Inter-Integrated Circuit
IRQ	Interrupt Request
ISP	In-System Programming
LDO	Low DropOut regulator
MCU	MicroController Unit
MOV	Metal-Oxide Varistor
MPPT	Maximum Power Point Tracking
NTC	Negative Temperature Coefficient
PLL	Phase-Locked Loop
PV	PhotoVoltaic
PWM	Pulse-Width Modulator
RISC	Reduced Instruction Set Computer
SMD	Surface Mounted Device
SPI	Serial Peripheral Interface
SRAM	Static Random Access Memory
SSP	Synchronous Serial Port
STC	Standard Test Conditions
UART	Universal Asynchronous Receiver/Transmitter

14. Legal information

14.1 Definitions

Draft — The document is a draft version only. The content is still under internal review and subject to formal approval, which may result in modifications or additions. NXP Semiconductors does not give any representations or warranties as to the accuracy or completeness of information included herein and shall have no liability for the consequences of use of such information.

14.2 Disclaimers

Limited warranty and liability — Information in this document is believed to be accurate and reliable. However, NXP Semiconductors does not give any representations or warranties, expressed or implied, as to the accuracy or completeness of such information and shall have no liability for the consequences of use of such information.

In no event shall NXP Semiconductors be liable for any indirect, incidental, punitive, special or consequential damages (including - without limitation - lost profits, lost savings, business interruption, costs related to the removal or replacement of any products or rework charges) whether or not such damages are based on tort (including negligence), warranty, breach of contract or any other legal theory.

Notwithstanding any damages that customer might incur for any reason whatsoever, NXP Semiconductors' aggregate and cumulative liability towards customer for the products described herein shall be limited in accordance with the *Terms and conditions of commercial sale* of NXP Semiconductors.

Right to make changes — NXP Semiconductors reserves the right to make changes to information published in this document, including without limitation specifications and product descriptions, at any time and without notice. This document supersedes and replaces all information supplied prior to the publication hereof.

Suitability for use — NXP Semiconductors products are not designed, authorized or warranted to be suitable for use in life support, life-critical or safety-critical systems or equipment, nor in applications where failure or malfunction of an NXP Semiconductors product can reasonably be expected to result in personal injury, death or severe property or environmental damage. NXP Semiconductors accepts no liability for inclusion and/or use of NXP Semiconductors products in such equipment or applications and therefore such inclusion and/or use is at the customer's own risk.

Applications — Applications that are described herein for any of these products are for illustrative purposes only. NXP Semiconductors makes no representation or warranty that such applications will be suitable for the specified use without further testing or modification.

Customers are responsible for the design and operation of their applications and products using NXP Semiconductors products, and NXP Semiconductors accepts no liability for any assistance with applications or customer product

design. It is customer's sole responsibility to determine whether the NXP Semiconductors product is suitable and fit for the customer's applications and products planned, as well as for the planned application and use of customer's third party customer(s). Customers should provide appropriate design and operating safeguards to minimize the risks associated with their applications and products.

NXP Semiconductors does not accept any liability related to any default, damage, costs or problem which is based on any weakness or default in the customer's applications or products, or the application or use by customer's third party customer(s). Customer is responsible for doing all necessary testing for the customer's applications and products using NXP Semiconductors products in order to avoid a default of the applications and the products or of the application or use by customer's third party customer(s). NXP does not accept any liability in this respect.

Export control — This document as well as the item(s) described herein may be subject to export control regulations. Export might require a prior authorization from national authorities.

Evaluation products — This product is provided on an "as is" and "with all faults" basis for evaluation purposes only. NXP Semiconductors, its affiliates and their suppliers expressly disclaim all warranties, whether express, implied or statutory, including but not limited to the implied warranties of non-infringement, merchantability and fitness for a particular purpose. The entire risk as to the quality, or arising out of the use or performance, of this product remains with customer.

In no event shall NXP Semiconductors, its affiliates or their suppliers be liable to customer for any special, indirect, consequential, punitive or incidental damages (including without limitation damages for loss of business, business interruption, loss of use, loss of data or information, and the like) arising out of the use of or inability to use the product, whether or not based on tort (including negligence), strict liability, breach of contract, breach of warranty or any other theory, even if advised of the possibility of such damages.

Notwithstanding any damages that customer might incur for any reason whatsoever (including without limitation, all damages referenced above and all direct or general damages), the entire liability of NXP Semiconductors, its affiliates and their suppliers and customer's exclusive remedy for all of the foregoing shall be limited to actual damages incurred by customer based on reasonable reliance up to the greater of the amount actually paid by customer for the product or five dollars (US\$5.00). The foregoing limitations, exclusions and disclaimers shall apply to the maximum extent permitted by applicable law, even if any remedy fails of its essential purpose.

14.3 Trademarks

Notice: All referenced brands, product names, service names and trademarks are the property of their respective owners.

I²C-bus — logo is a trademark of NXP B.V.

15. Contents

1	Introduction	3	11	Steps for evaluating the charge controller reference system	35
1.1	Solar photovoltaic energy and maximum power point	3	11.1	Testing functionality	35
1.2	Solar charge controller	4	11.2	Testing open loop efficiency	36
2	MPT612 IC	6	12	Steps to link and test new applications	38
3	MPT612 software	7	13	Abbreviations	38
3.1	Software memory size	8	14	Legal information	39
4	MPPT charge controller reference system	9	14.1	Definitions	39
4.1	System specifications	9	14.2	Disclaimers	39
4.2	MPPT charge controller reference system block	11	14.3	Trademarks	39
5	Schematics	12	15	Contents	40
5.1	Charge controller reference system boards ..	12			
5.1.1	Charge controller board	12			
5.1.2	JTAG/UART add-on board	14			
5.2	Charge controller reference system; major circuit blocks	15			
5.2.1	PV voltage and current sense circuit	15			
5.2.2	Battery voltage and current circuit	16			
5.2.3	DC-DC buck-boost converter power electronics circuit	18			
5.2.4	MPT612 digital circuit	19			
5.2.5	Charge controller board power supply circuit ..	21			
5.2.6	JTAG/UART add-on board circuit diagram ..	22			
6	Charge controller reference system bill of materials	23			
6.1	Charge controller board Bill Of Materials (BOM)	23			
6.2	JTAG/UART add-on board Bill Of Materials (BOM)	26			
7	Component selection	26			
7.1	PV System parameters	26			
7.2	Major components	26			
7.2.1	Frequency of DC-DC converter operation ..	27			
7.2.2	Inductor	27			
7.2.3	Input bulk capacitor	27			
7.2.4	Switching MOSFET	28			
7.2.5	Output diode	28			
7.2.6	Output capacitor	28			
7.2.7	Thermal pads	29			
7.2.7.1	Thermal pad for D2PAK diode	29			
7.2.7.2	MOSFET thermal pad calculation	30			
8	System test plan	31			
9	Benchmarking strategy	34			
10	System test and benchmarking results	35			

Please be aware that important notices concerning this document and the product(s) described herein, have been included in section 'Legal information'.

© NXP B.V. 2011.

All rights reserved.

For more information, please visit: <http://www.nxp.com>

For sales office addresses, please send an email to: salesaddresses@nxp.com

Date of release: 2 February 2011

Document identifier: AN10936